

# System B

- 1= Product
- 2= PVC block  
60x40x30 mm
- 3= Nylon ring
- 4= Bolt  $\varnothing 6 \times 50$  mm
- 5= Cap
- 6= Threaded rod M8
- 7= Nut M8
- 8= Ring M8
- 9= Chemical anchor M8

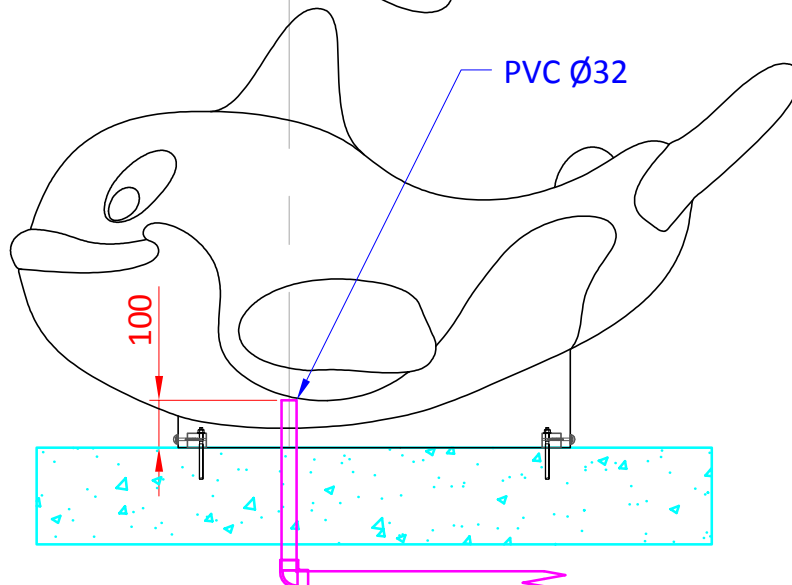
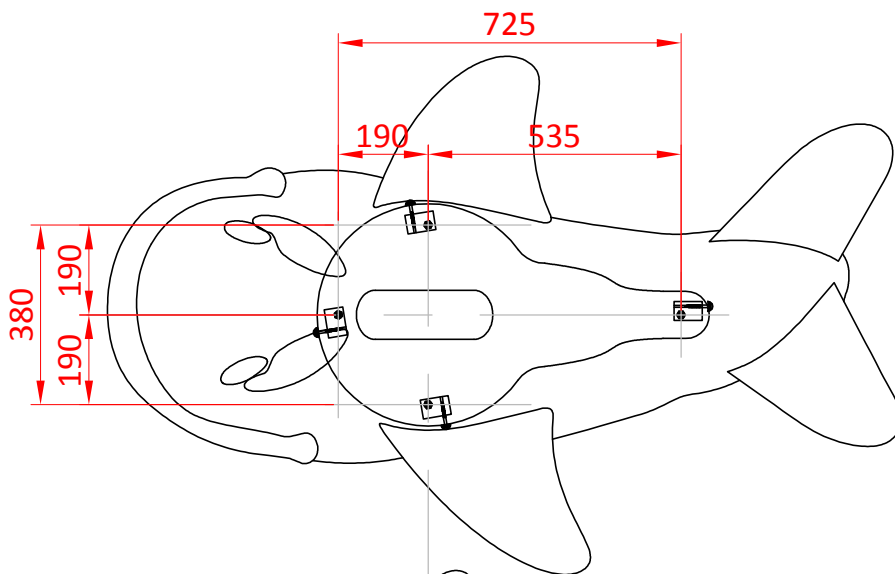
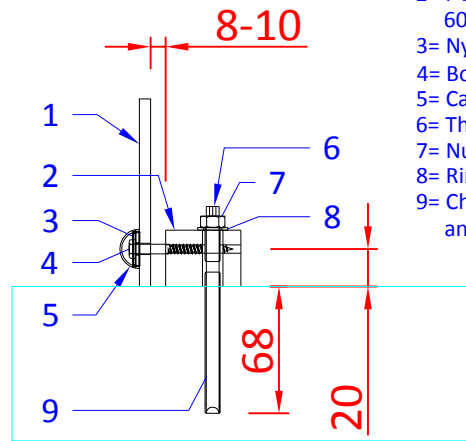

Sportlaan 9, 5683 CS Best, The Netherlands  
 T +31 (0)499 393 540 | F +31 (0)499 393 744  
 E info@aquadrolics.nl | www.aquadrolics.nl

PROJECT NAME:

Montage

DRAWING NR:

2.3.1

PRODUCT:

1110 9704 Orka

SCALE:

FTS

FORMAT:

A4

DATE:

14-11-2014

PROJECTION:

DIMENSION:

mm

DRAWN BY:

KH

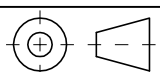



**AQUA DROLICS**  
Mounting system B

**Tools:**

- drilling machine
- drill (steel) Ø 5 mm
- drill (concrete) Ø 10 mm
- steel brush Ø 11 mm
- pencil
- tape-measure
- wrench nr 10
- wrench nr 13

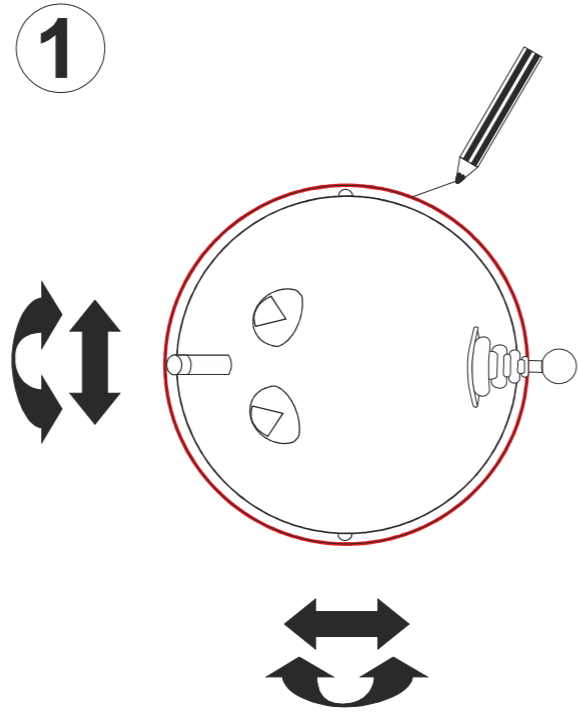

Determine the position of the product, then draw the contour with a pencil.

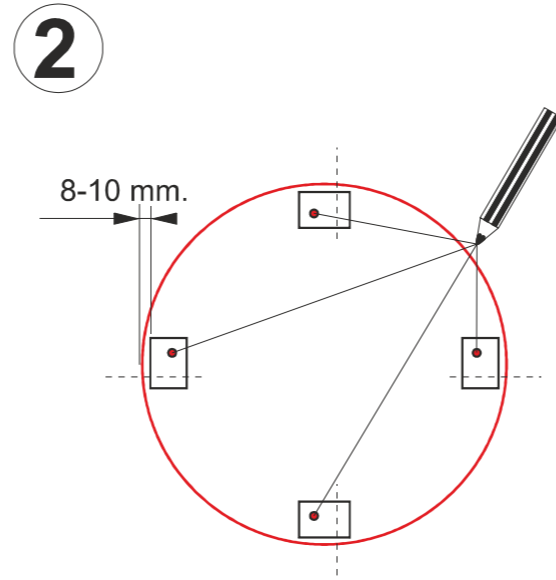

Position the PVC blocks at a distance of 8-10 mm from the edge of the product (as shown in drawing 2.3.1)

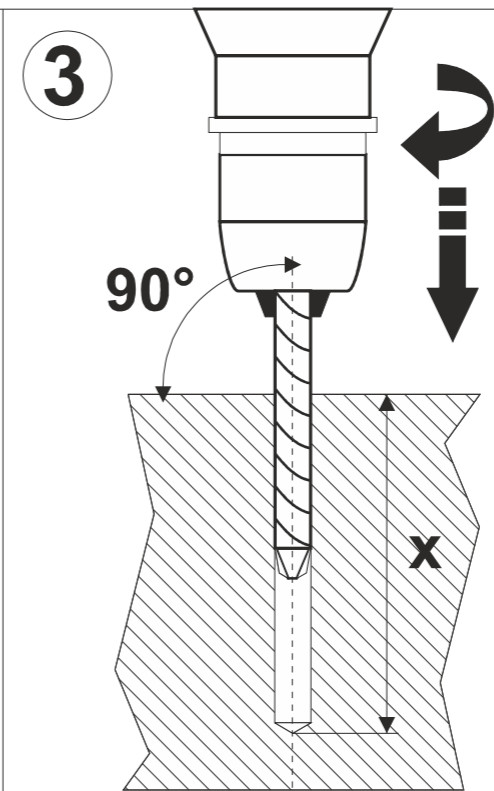

Drill holes Ø 10 in the sub-soil. Drilling depth is shown in the attached drawing.

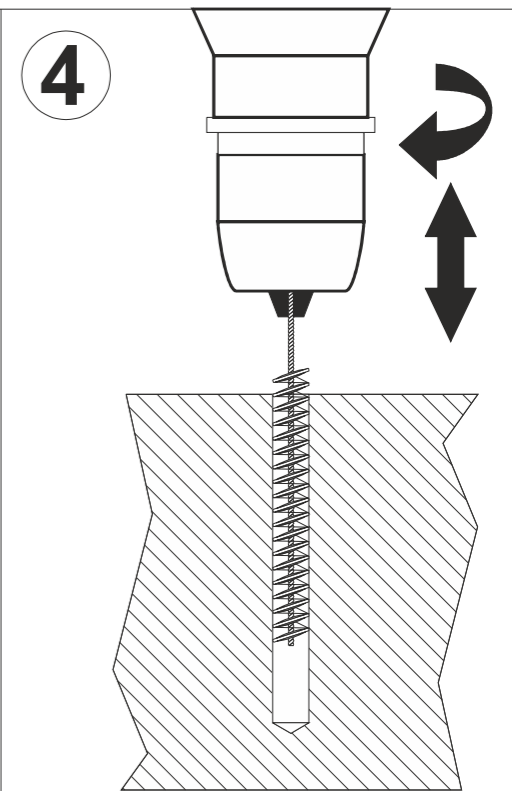

Brush the holes with the steel brush (Ø 11 mm). Remove any dust.

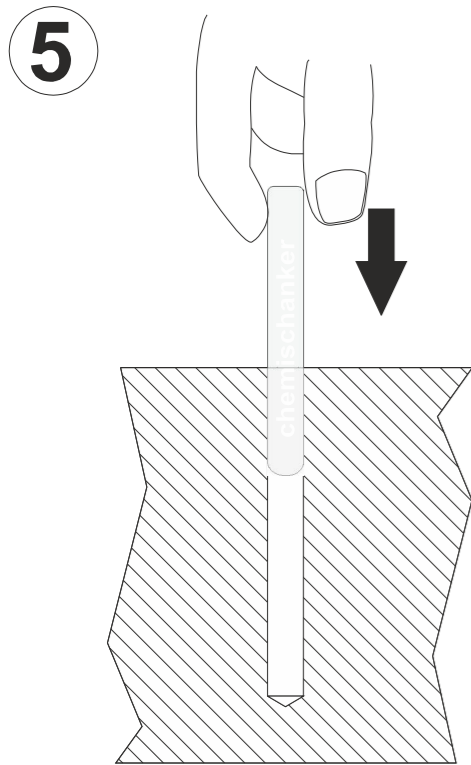

Insert capsule.

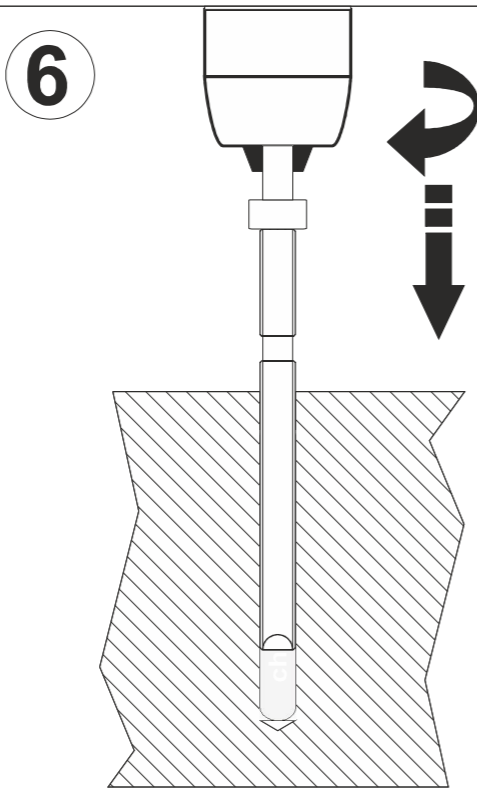

Insert anchor shaft, using the delivered tool.

	T = 10°C	T = 20°C
harden time dry concrete	40 min.	20 min.
harden time wet concrete	120 min.	60 min.

**7**

Leave the anchor to harden. Afterwards, remove any remains around the shaft.

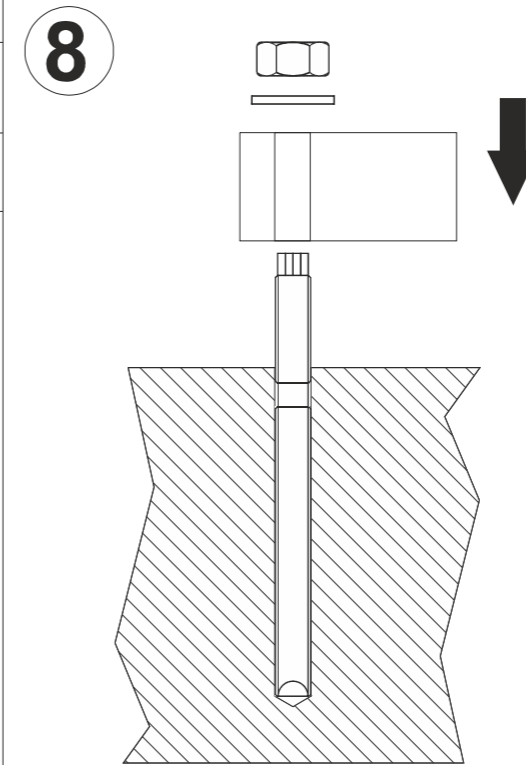

Mount the PVC blocks with ring and nut. Mark their location outside the outline of the product.

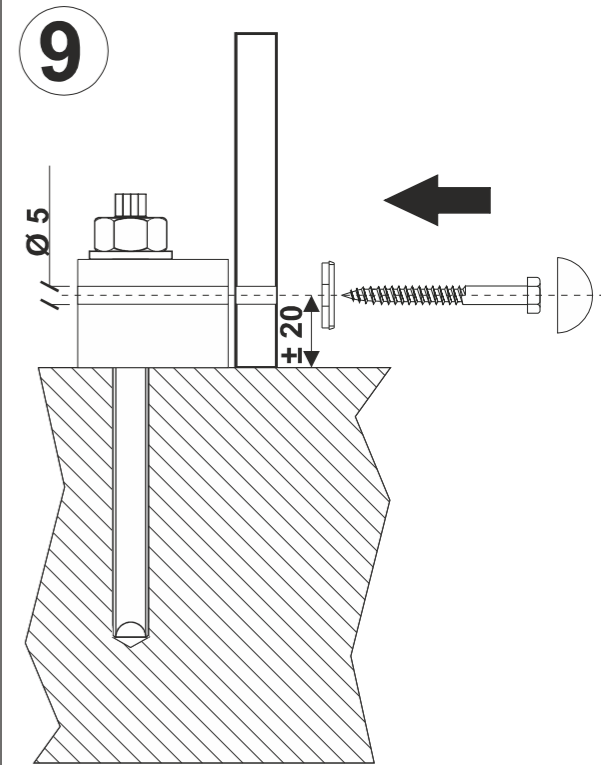

Place the product over the blocks. Drill a hole Ø 5 mm through the product in each of the PVC blocks. Fix the product on the blocks with the bolts Ø 6x50 mm. Put a nylon cap on every bolt.