

8452

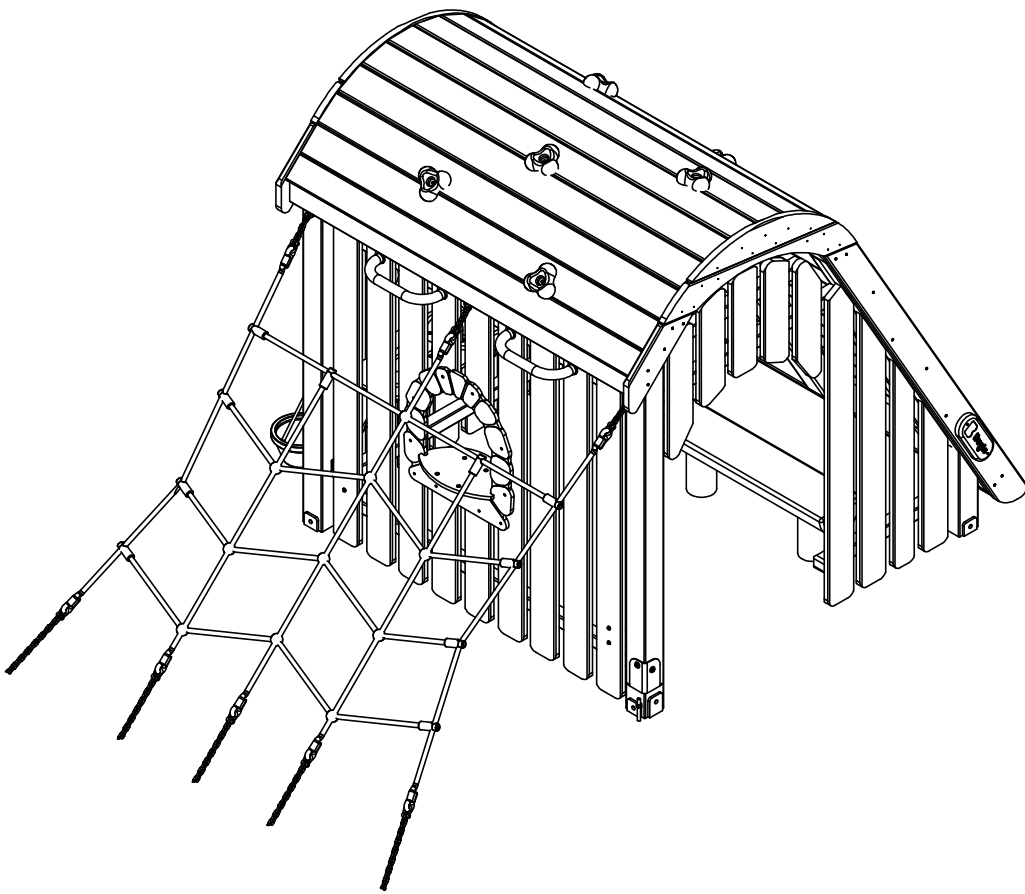

NR

ELEMENT

E1

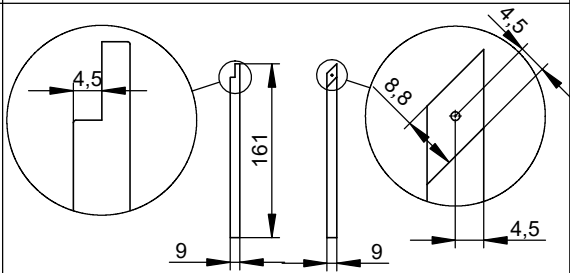

1

E2

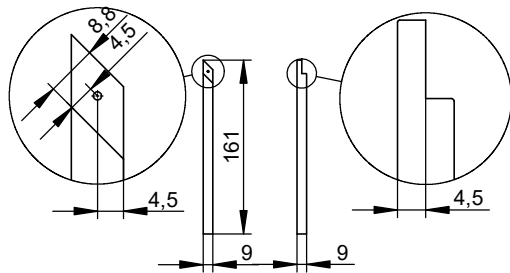

1

E3

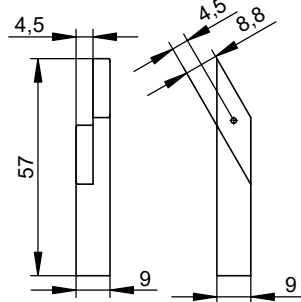

1

E4

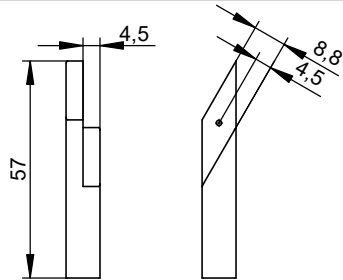

1

E5

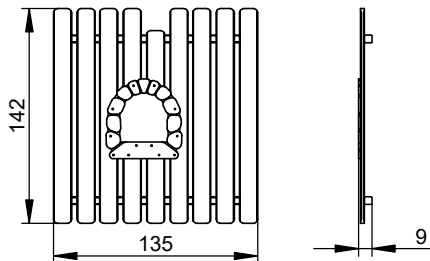

1

E6

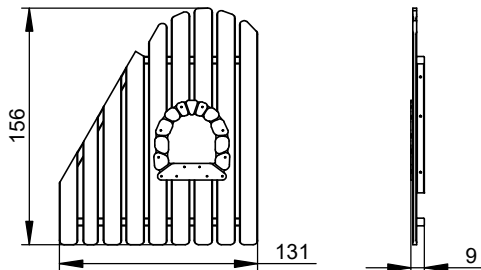

1

NR

ELEMENT

E7

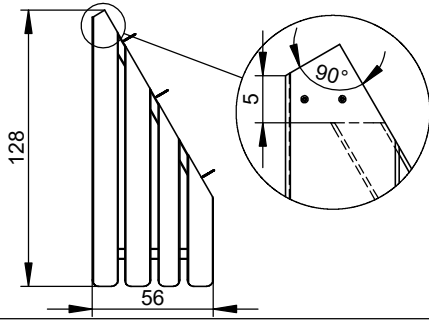

1

E8

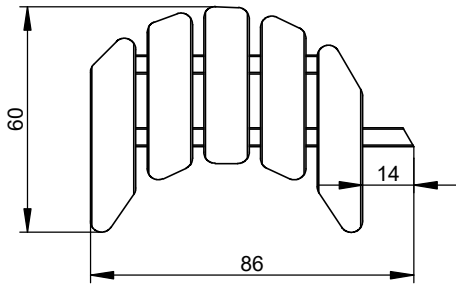

1

E9

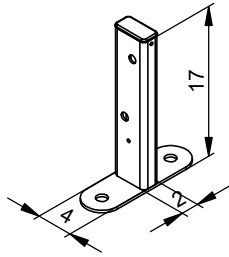

1

E10

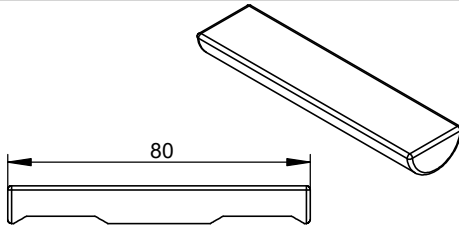

1

E11

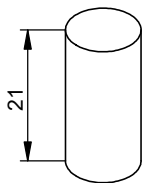

2

E12

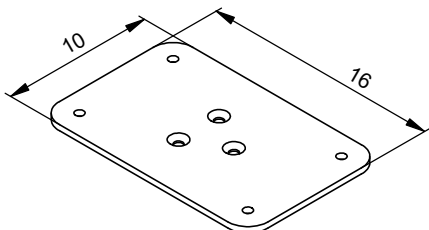

2

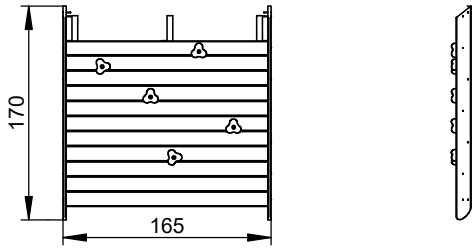
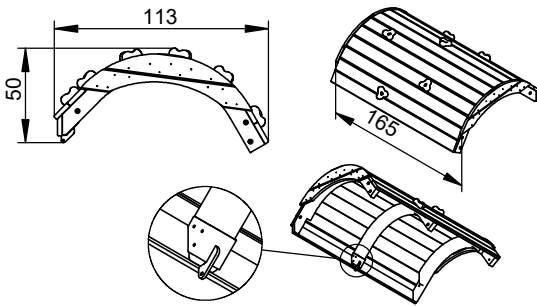
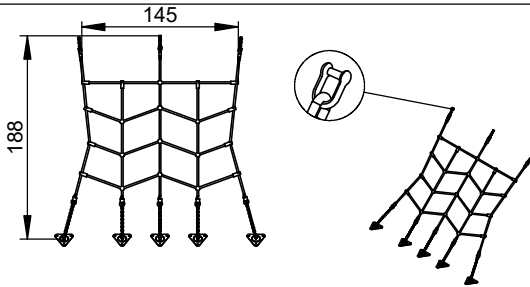
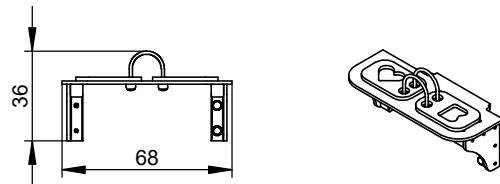
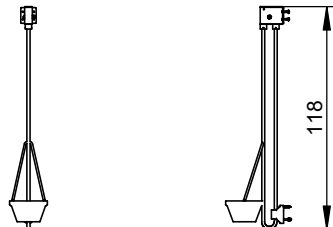
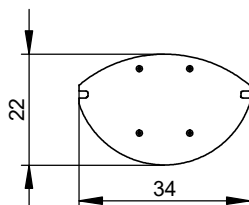
NR ELEMENT**E13****1****E14****1****E15****1****E16****1****E17****1****E18****1**

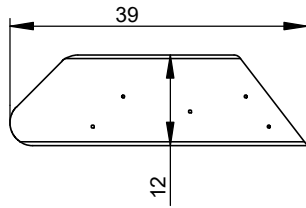
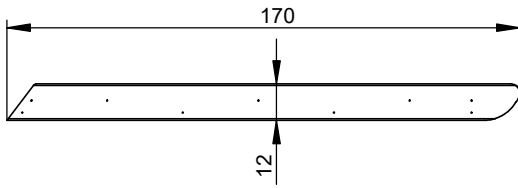
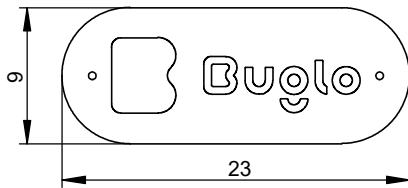
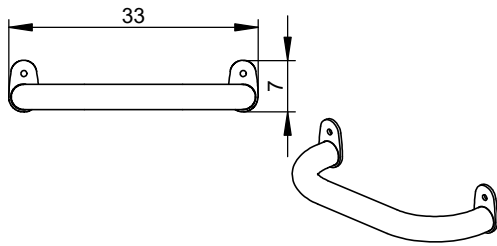
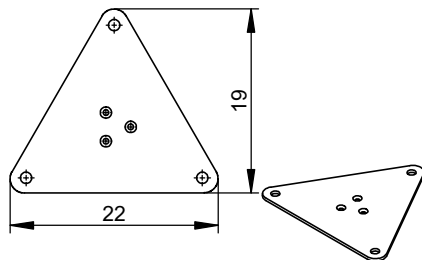
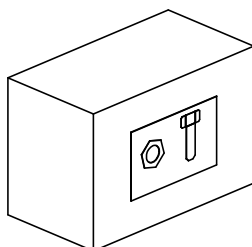
NR ELEMENT**E19****2****E20****2****E21****1****E22****2****E23****2****E24****1**

8452F

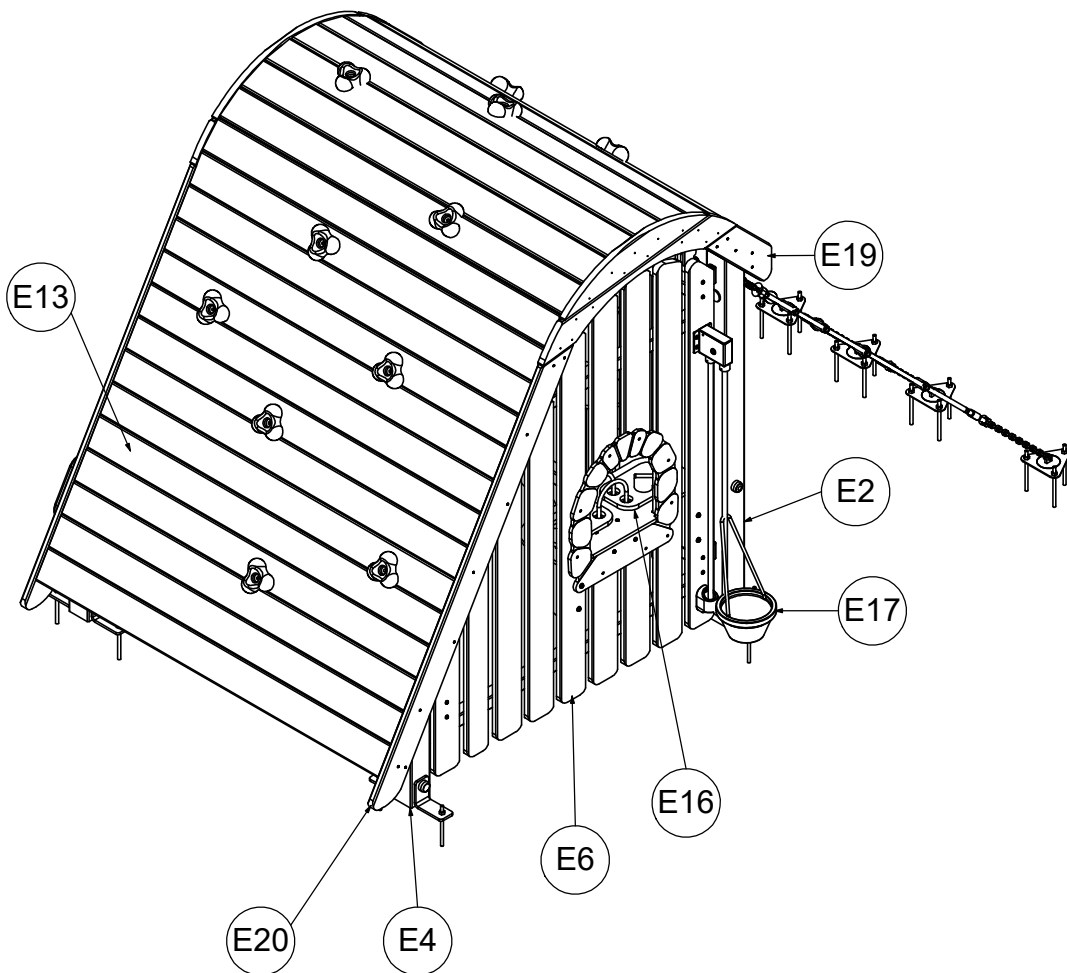
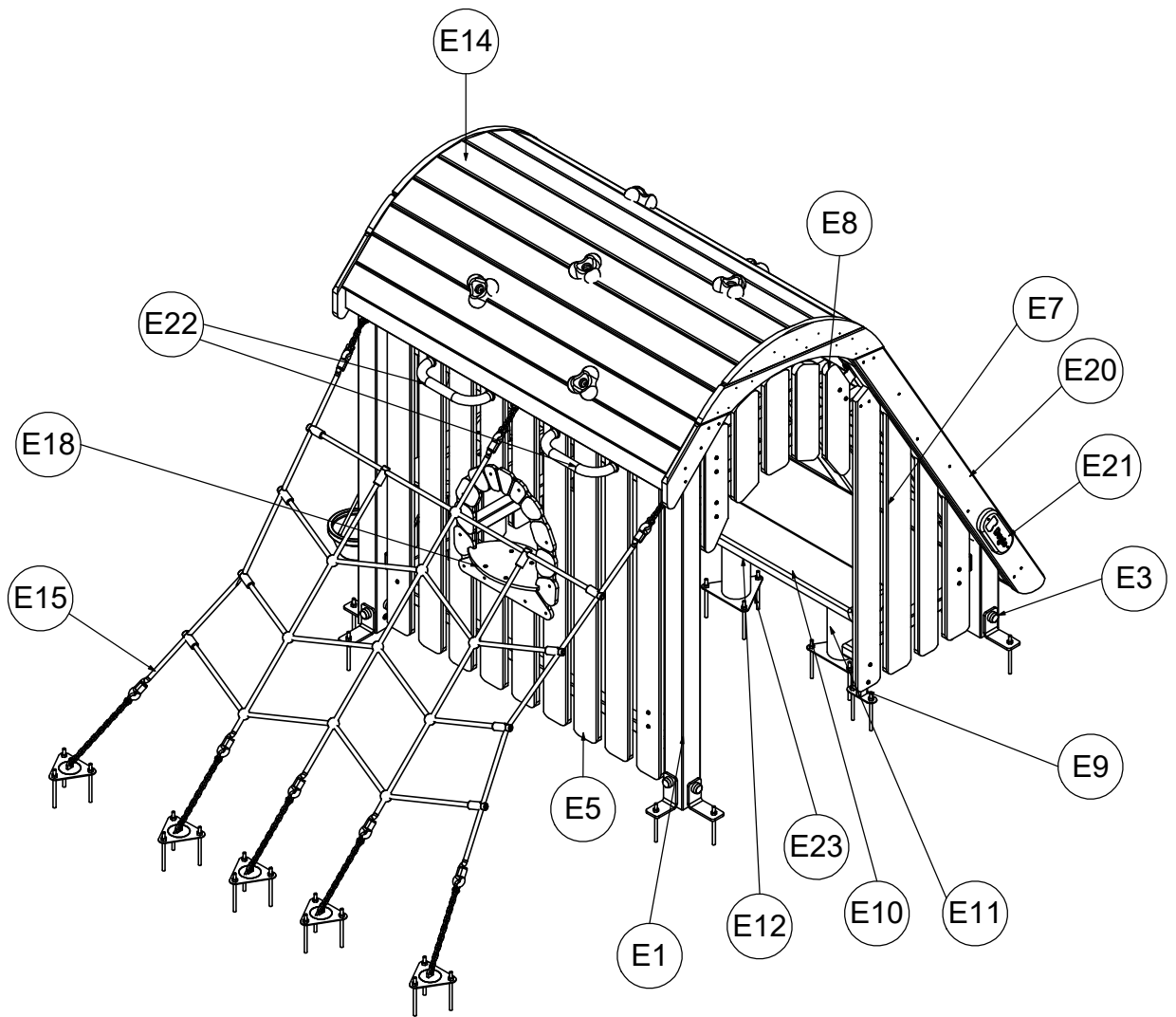

8452F

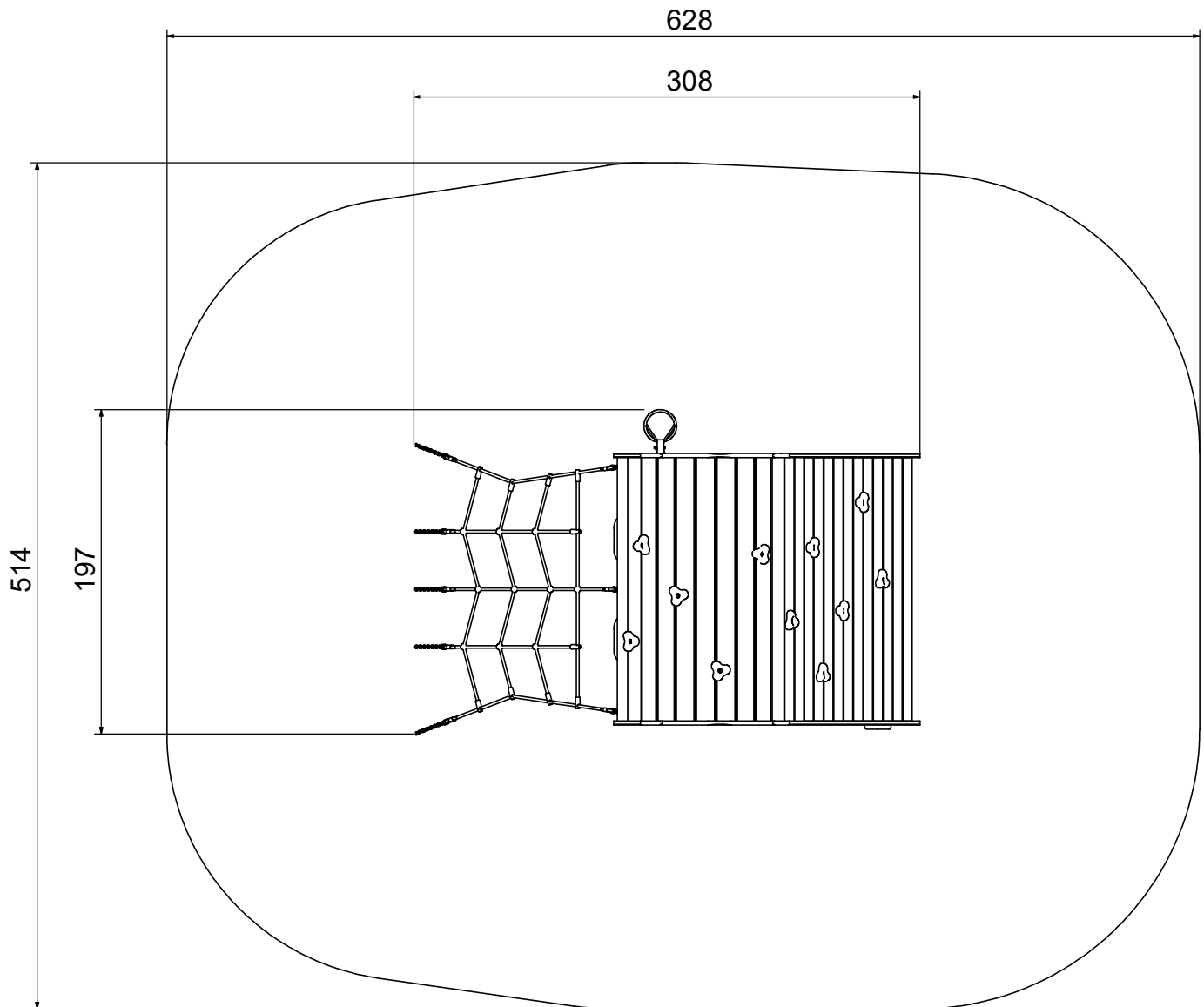
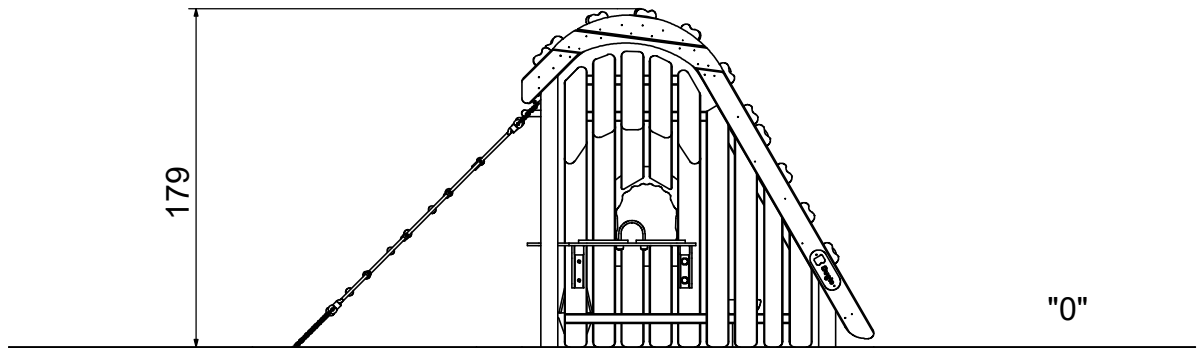

8452F

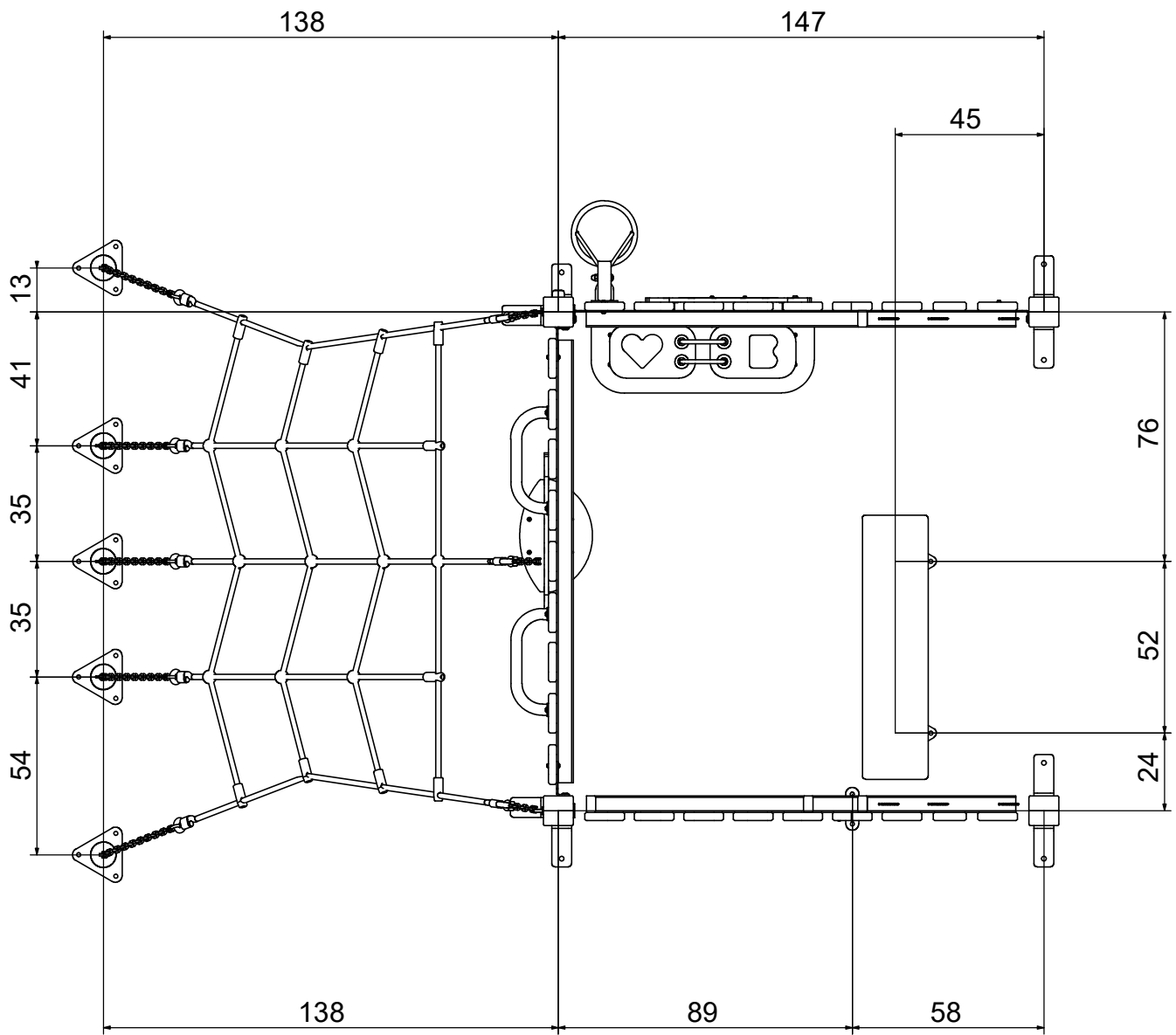

1

8452F

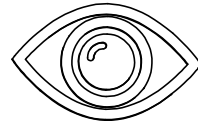

- INST_84_2
- INST_84_3
- INST_84_4A
- INST_84_34A
- INST_84_34B

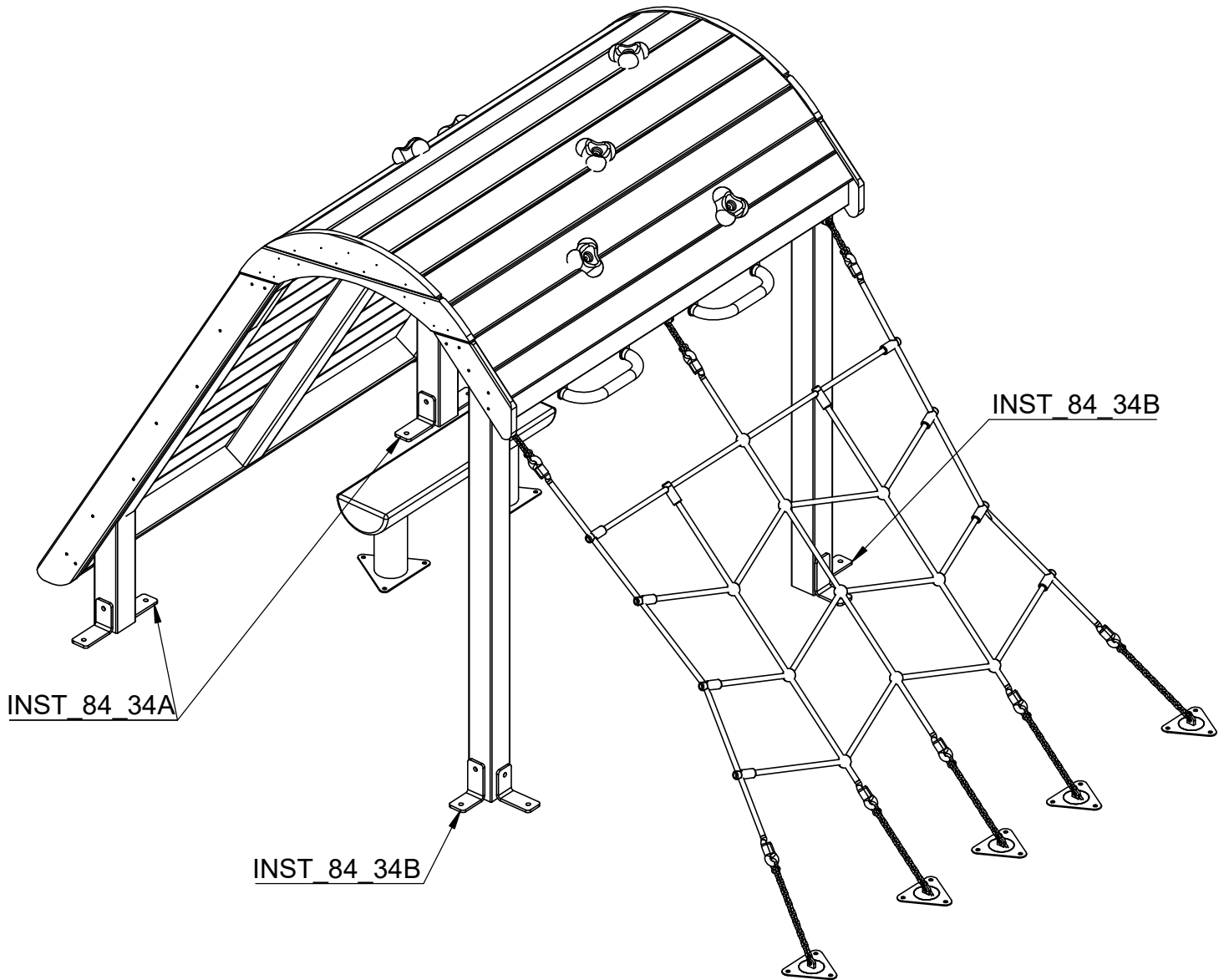

2

8452F

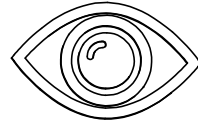

INST_84_1A
INST_84_1AA
INST_84_1B
INST_84_1C
INST_84_4A

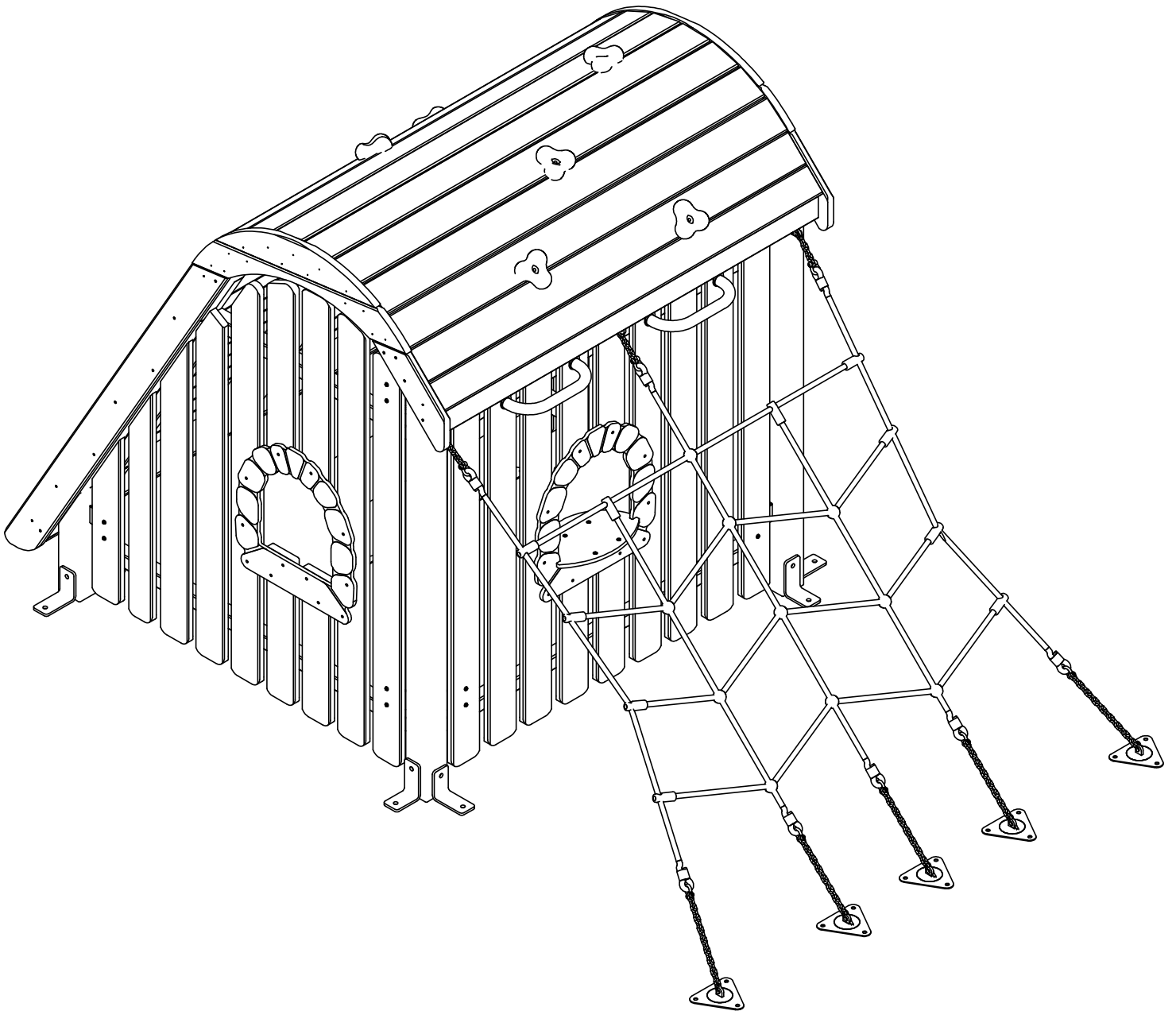

3

8452F

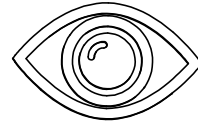

INST_81_132

INST_84_12

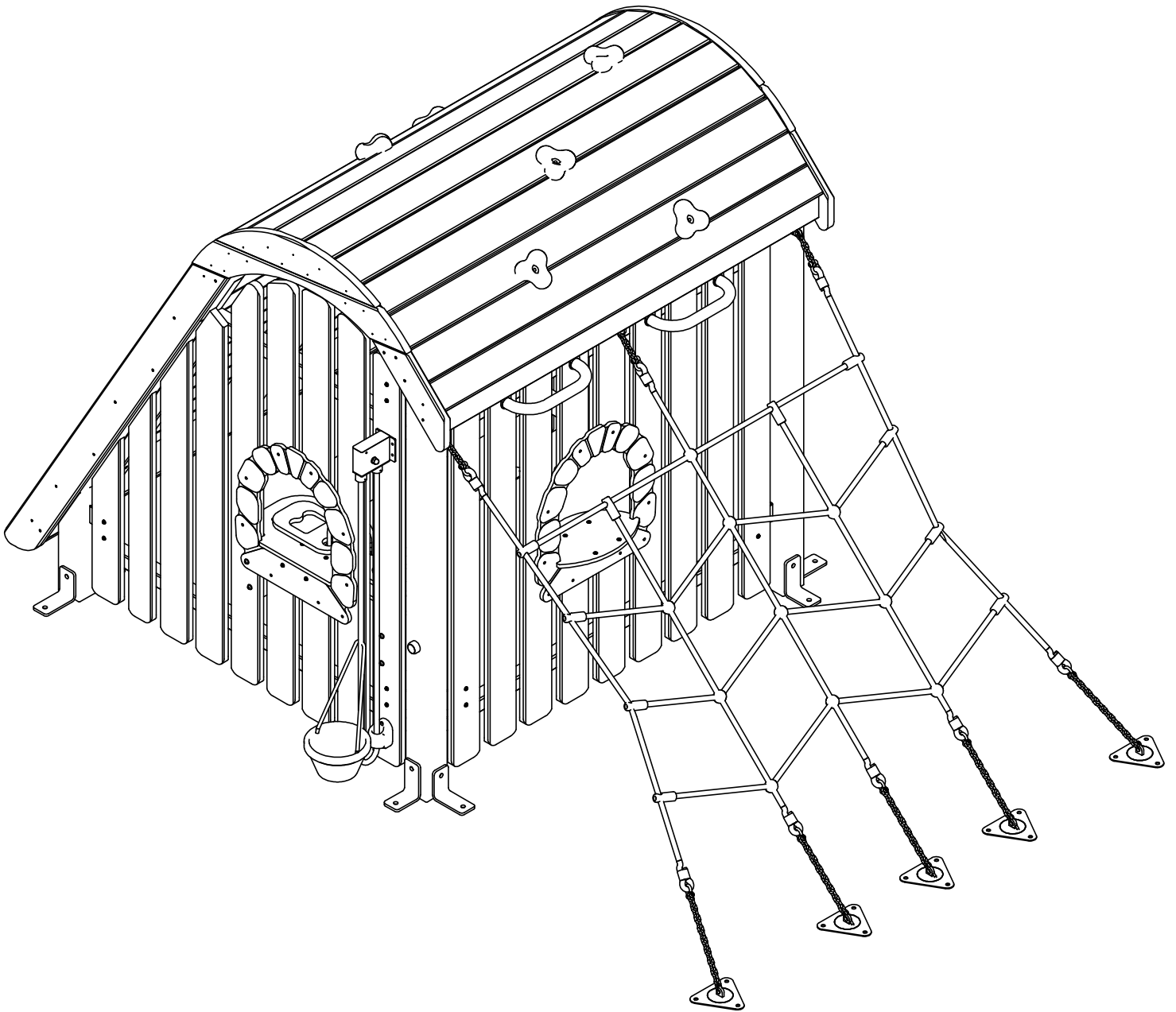

4

8452F

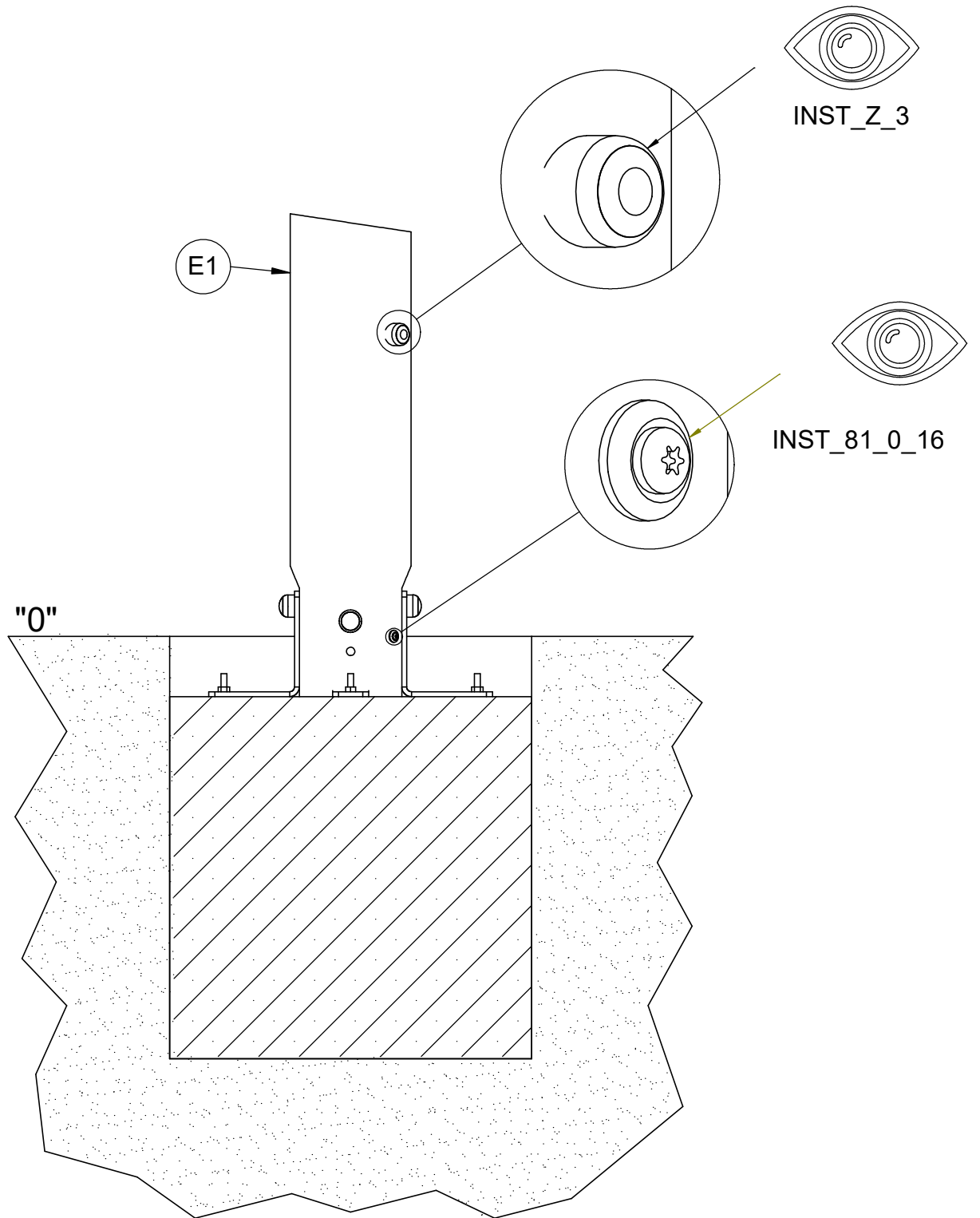

8452F

I

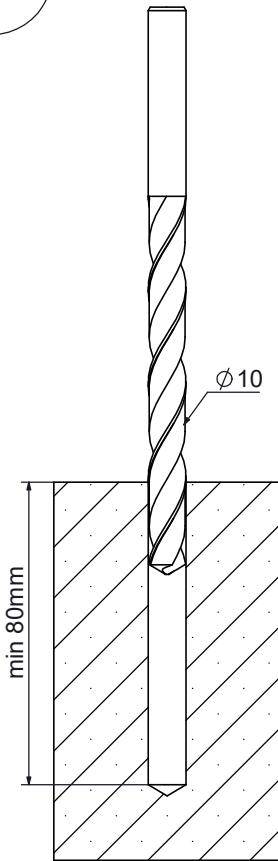

II

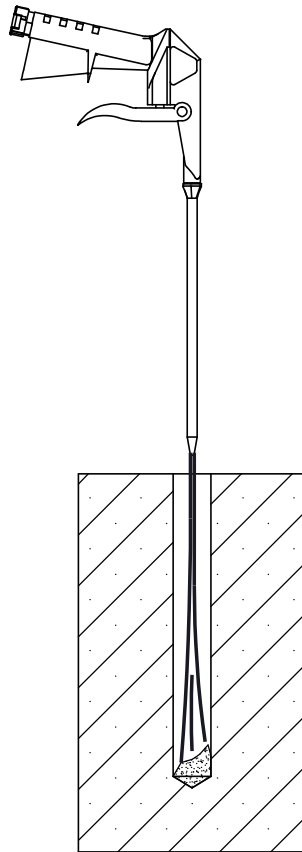

III

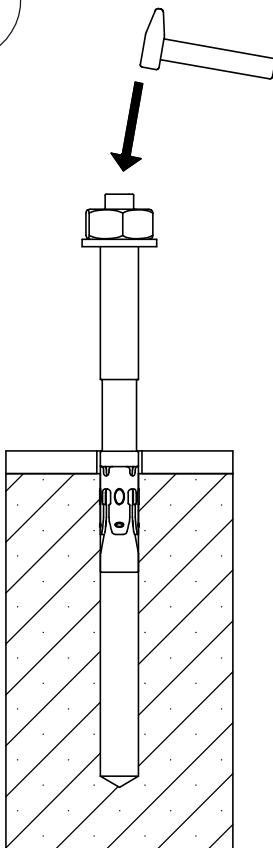

IV

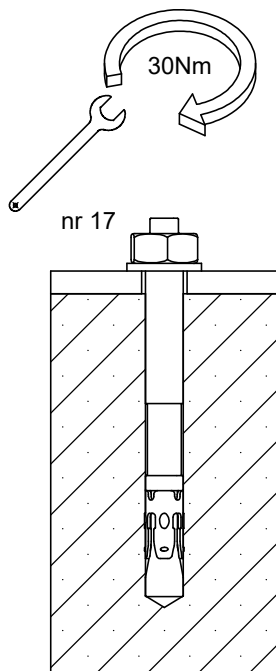

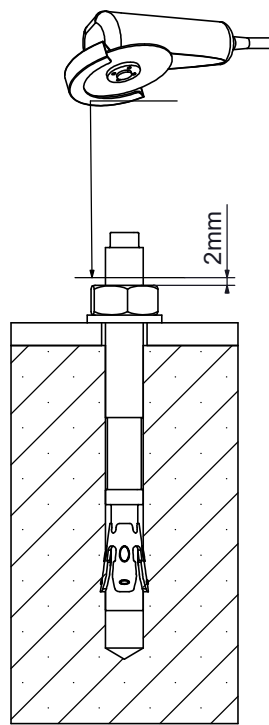

V

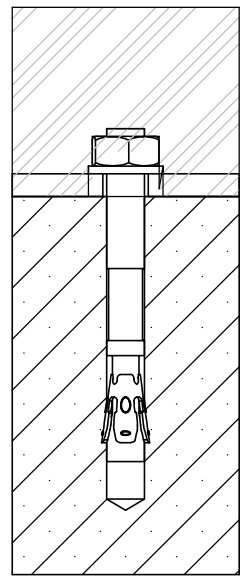

VI



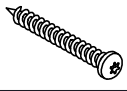



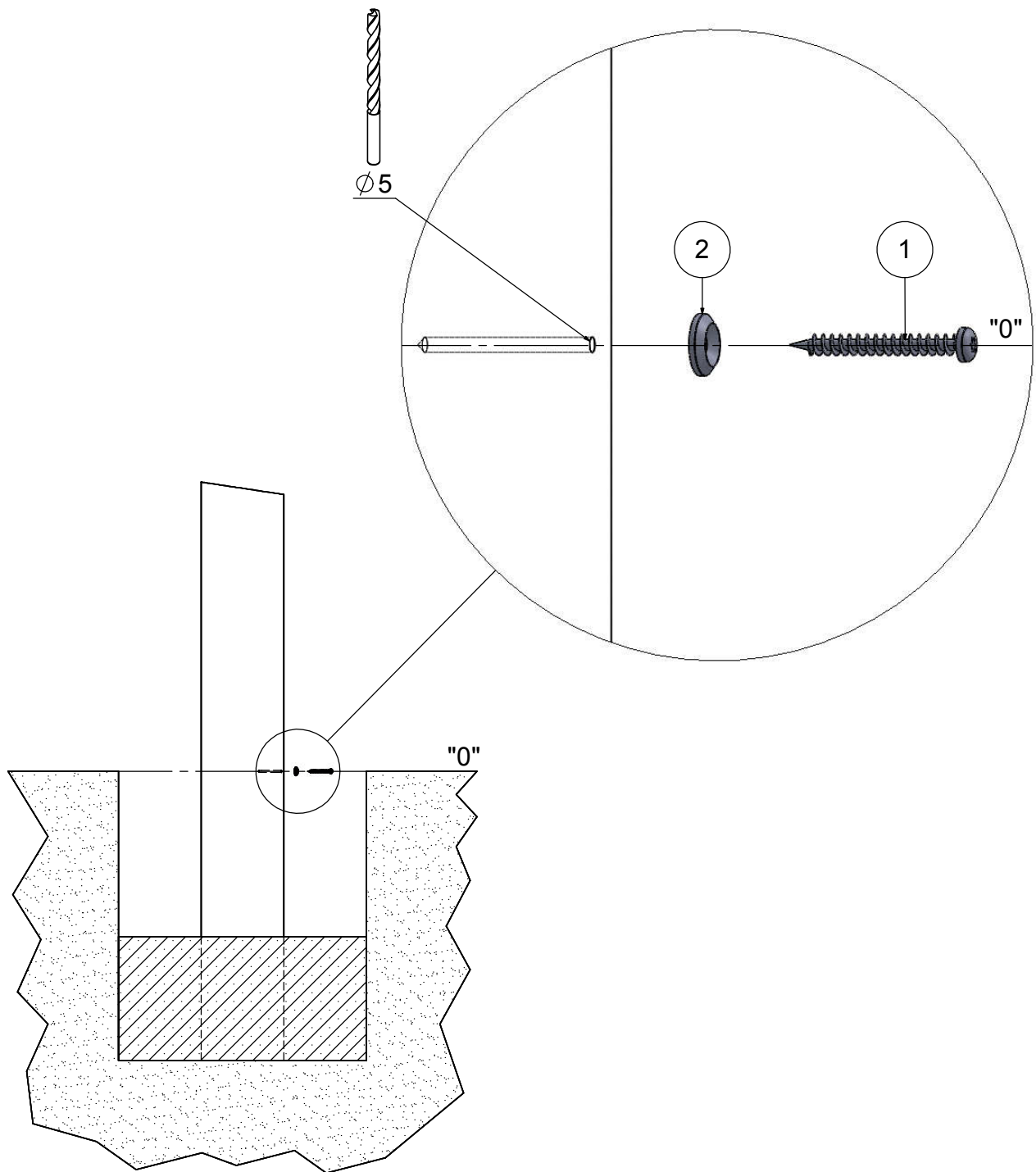

INST_81_0_16

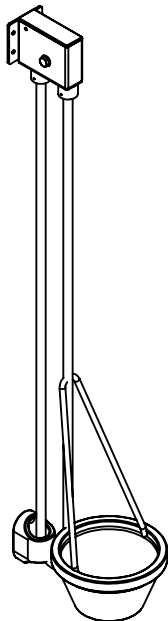
Nr	Σ	Element	DIN	ELEMENT
1	1		-	S6x60
2	1		-	W6x60

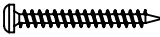

INST_81_132

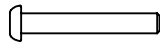

Nr	Σ	Element		
1	1		-	S6x60
15	4		ISO 7380	M6x30
21	5		DIN 125	8x16
22	4		DIN 125	6x12
23	4		-	M6x12
43	1		DIN 1587	M8
58	1		-	LOCTITE
116	1		ISO 7380	M8x55

1

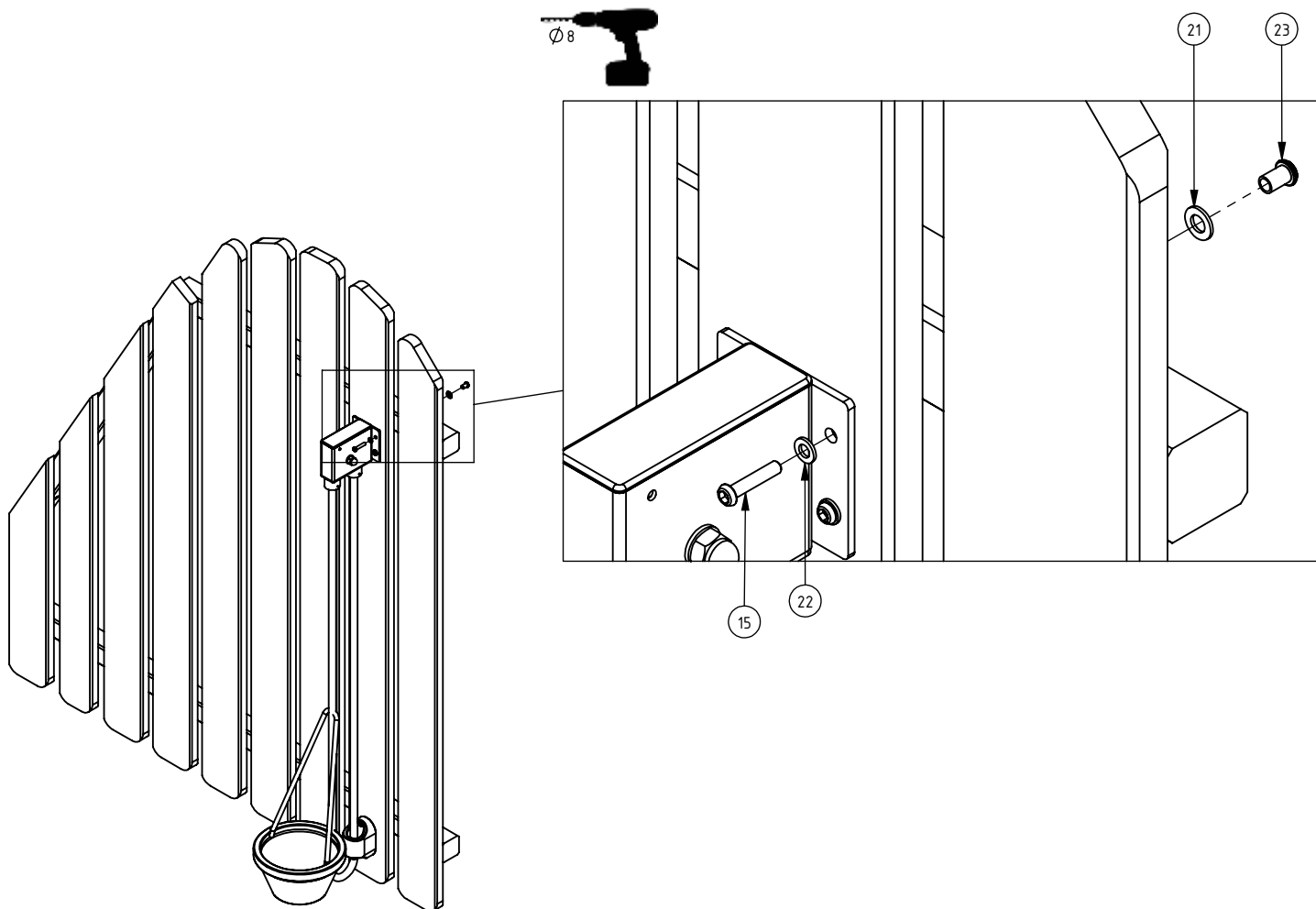
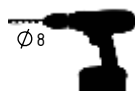

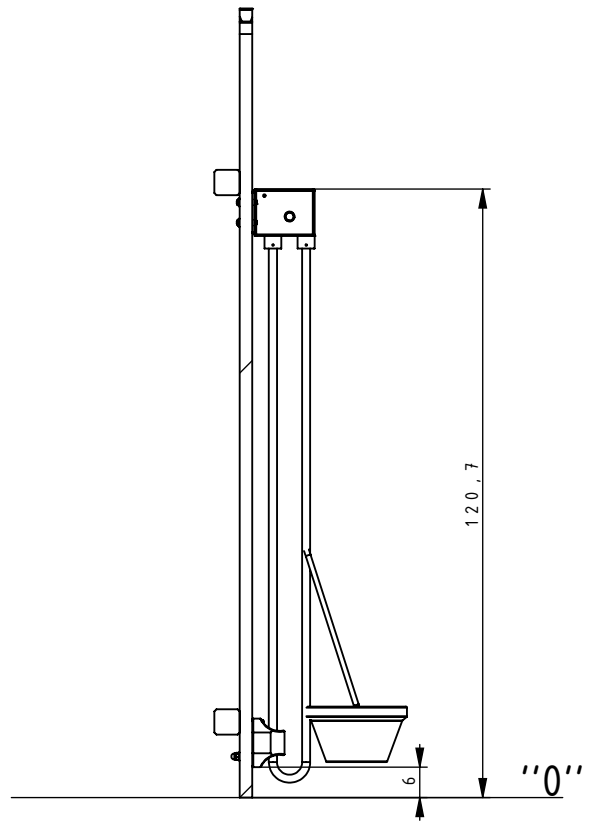
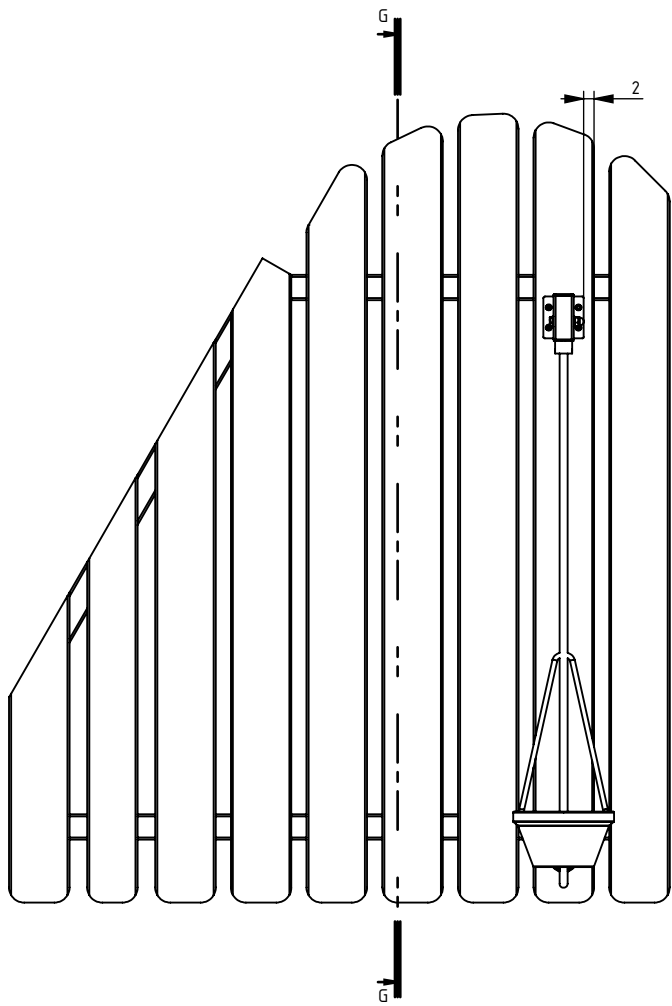

G-G (1 : 15)

2

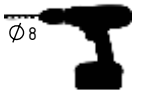
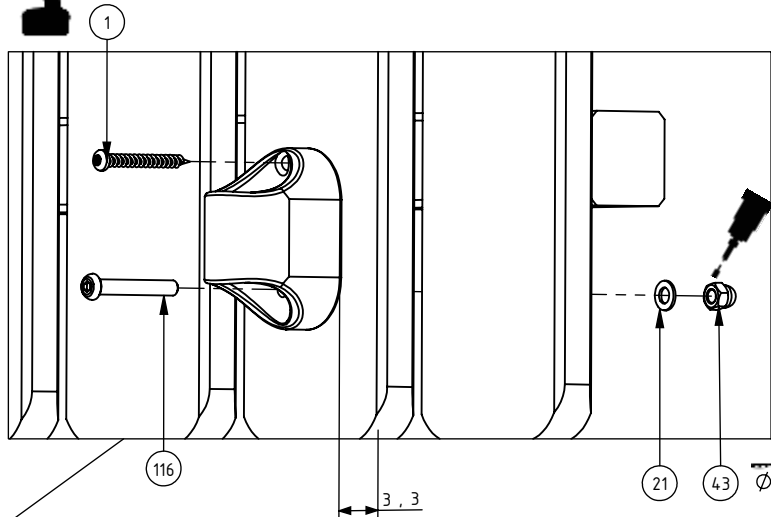
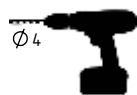
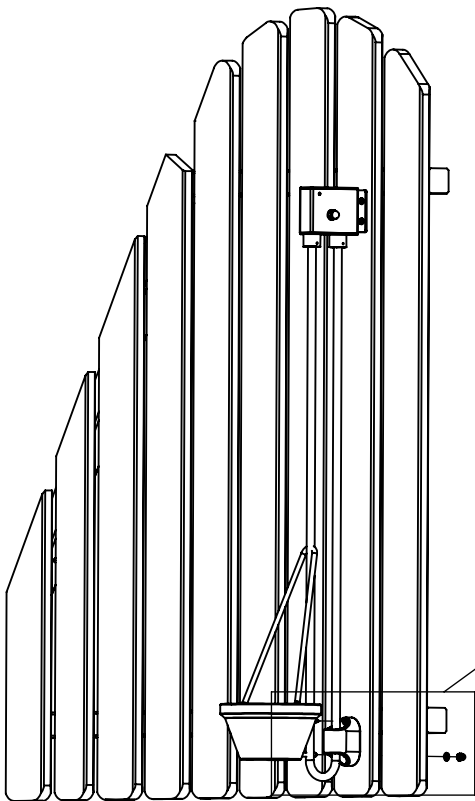

INST_84_1A

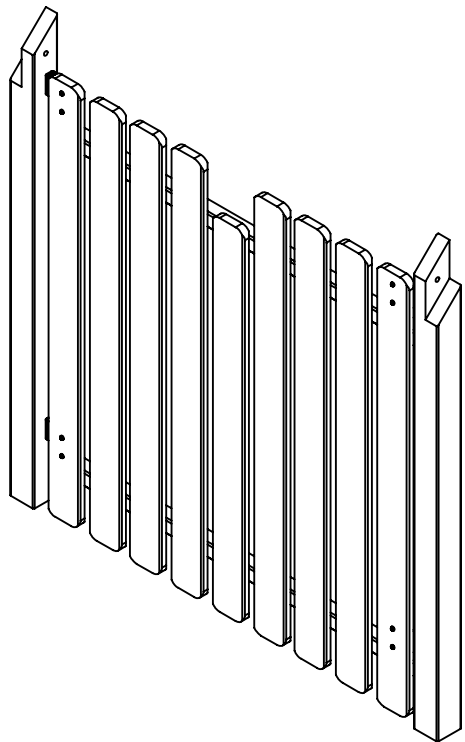





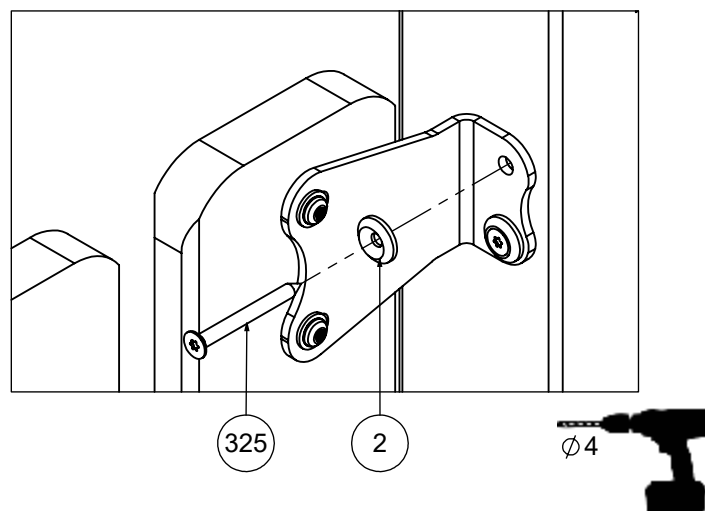
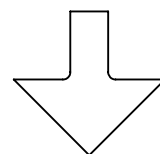
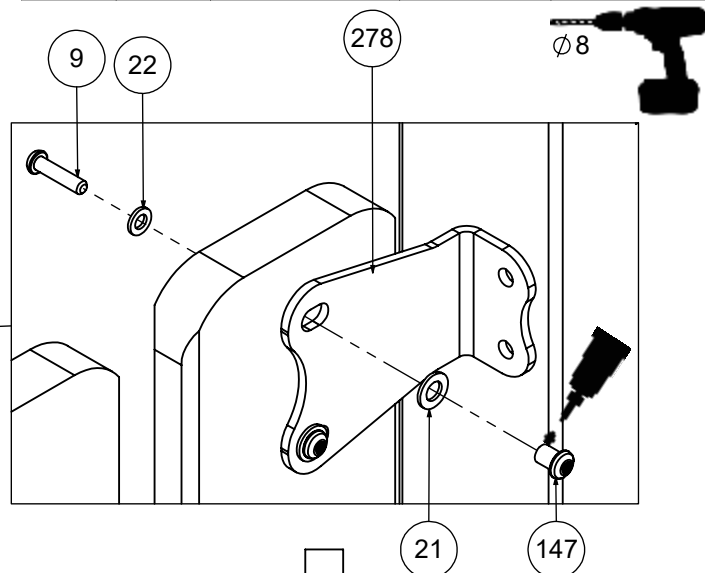
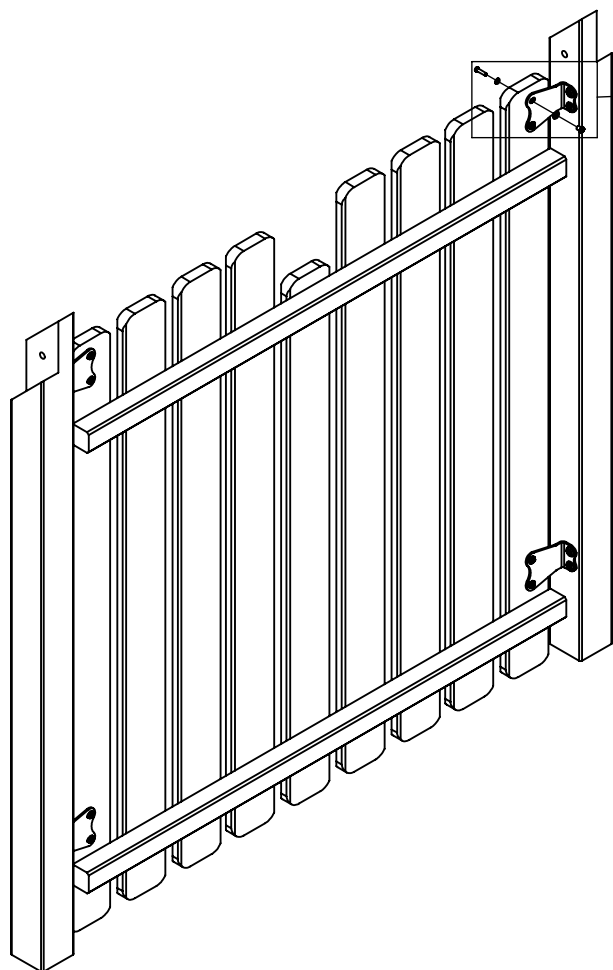

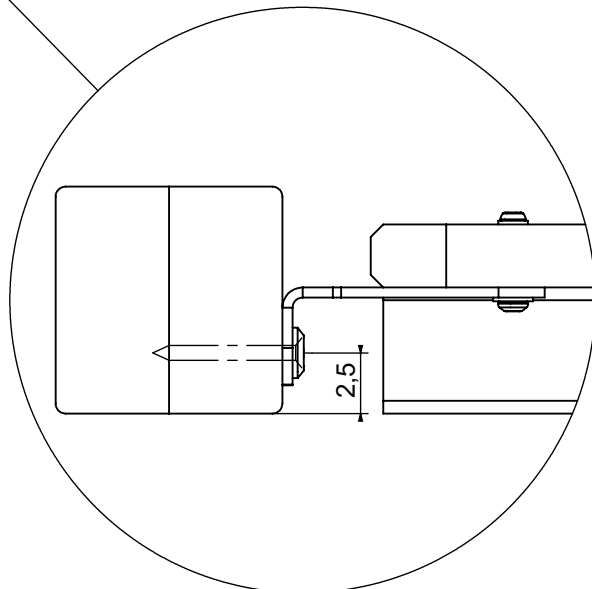
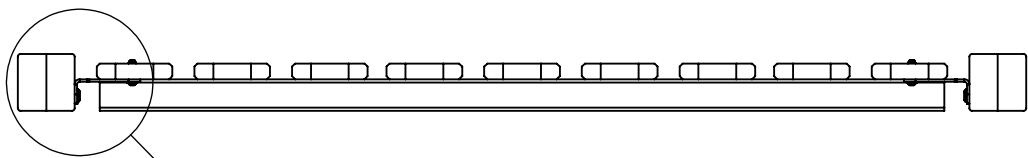
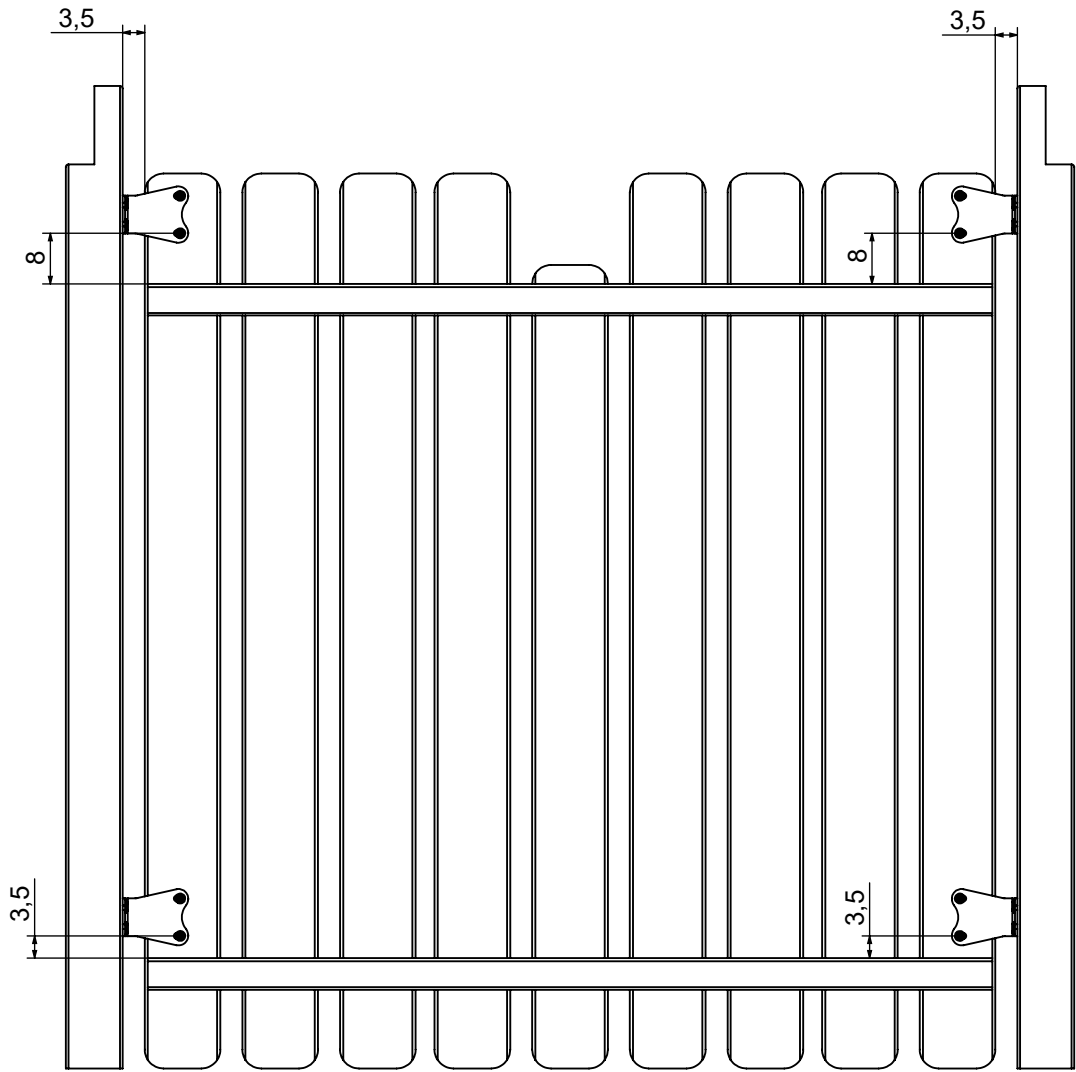
Nr	Σ	Element	DIN	ELEMENT
2	8		-	W6x60
9	8		ISO 7380	M6x25
21	8		DIN 125	8x16
22	8		DIN 125	6x12
58	1		-	LOCTITE
147	8		-	M6x10
278	4		-	8100_8_A2_g4_G_v3
325	8		9130	6x60

1



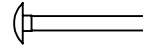

Nr	Σ	Element	DIN	ELEMENT
11	6		DIN 1587	M6
22	6		DIN 125	6x12
58	1		-	LOCTITE
132	4		DIN 7991	M6x25
550	2		DIN 603	M6x50
590	4			K_4_A2_g4_G_v1

1

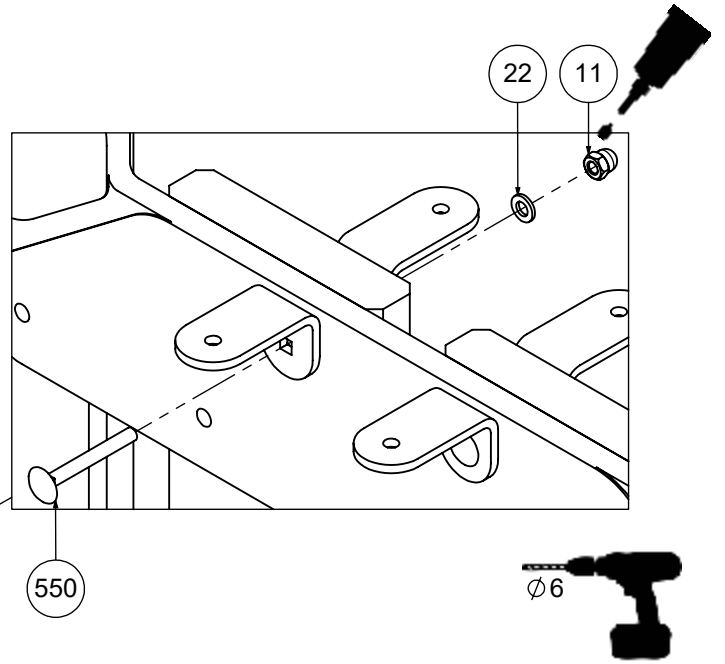
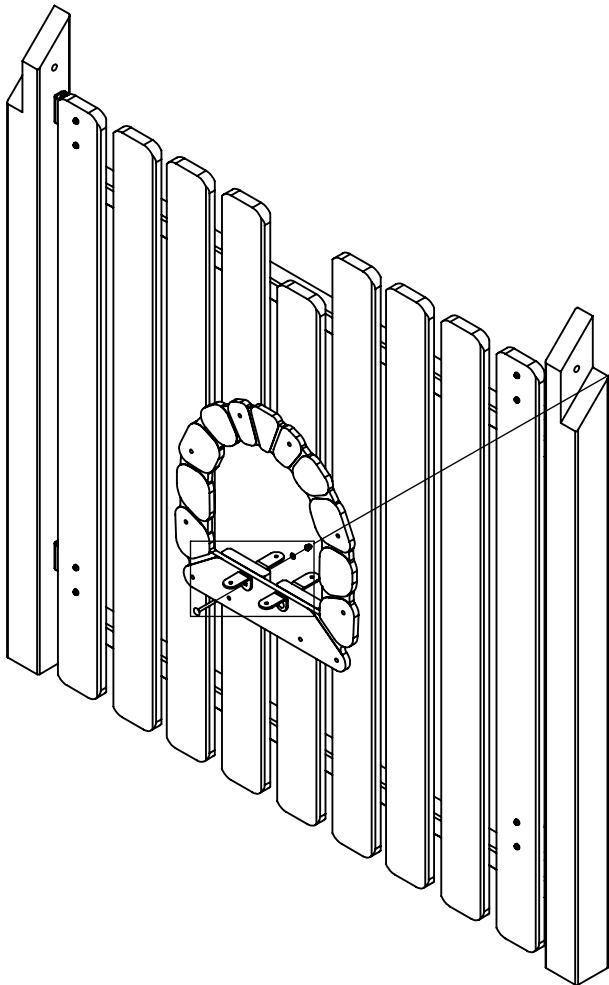

2

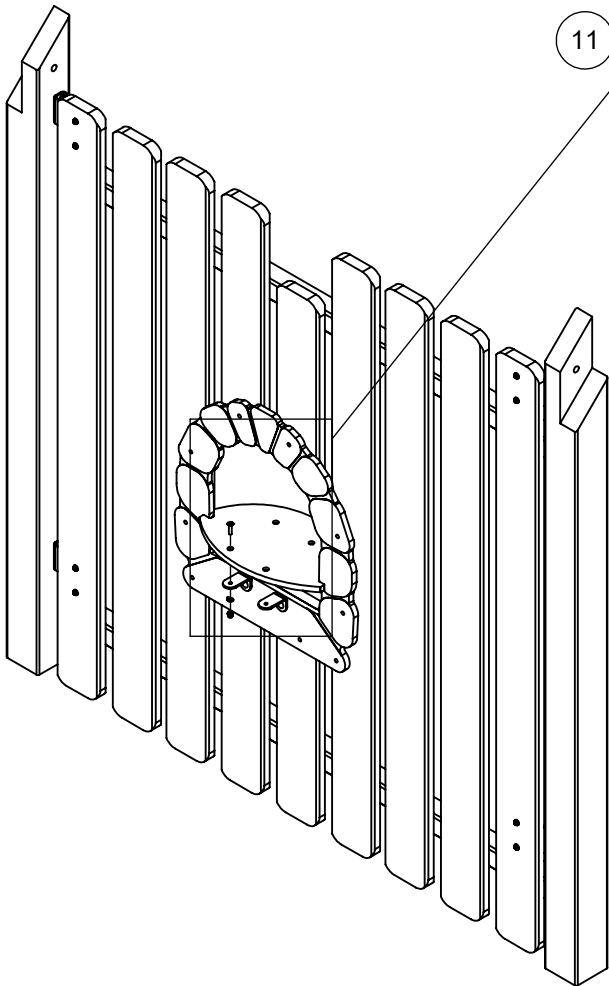
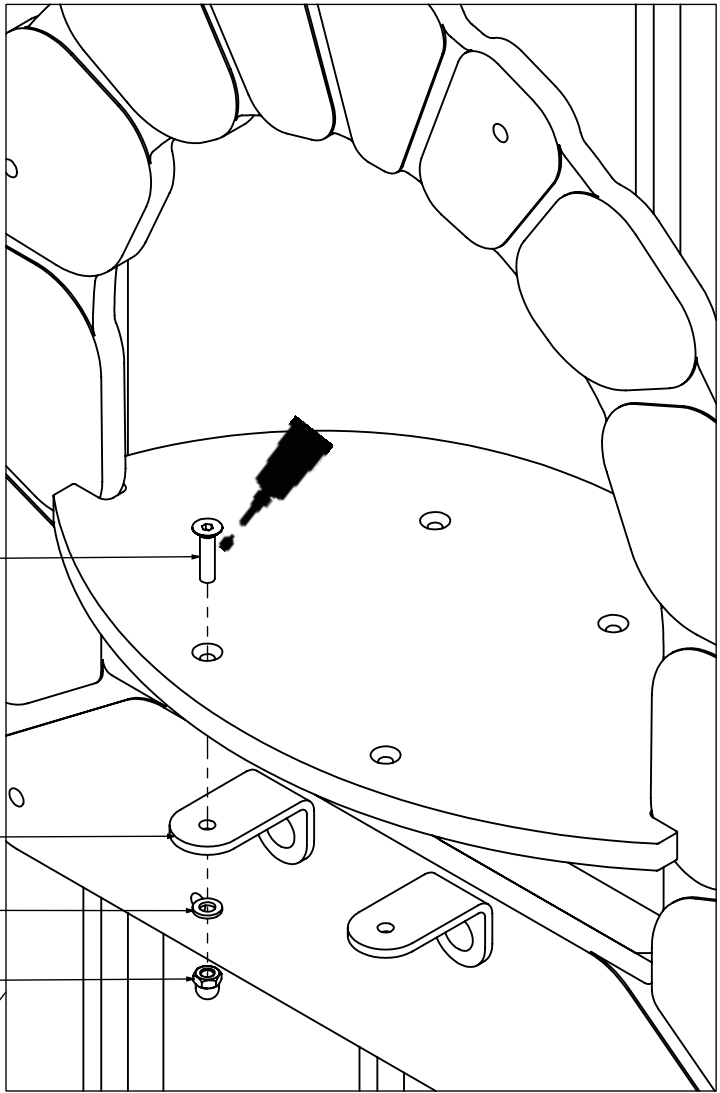

INST_84_1B

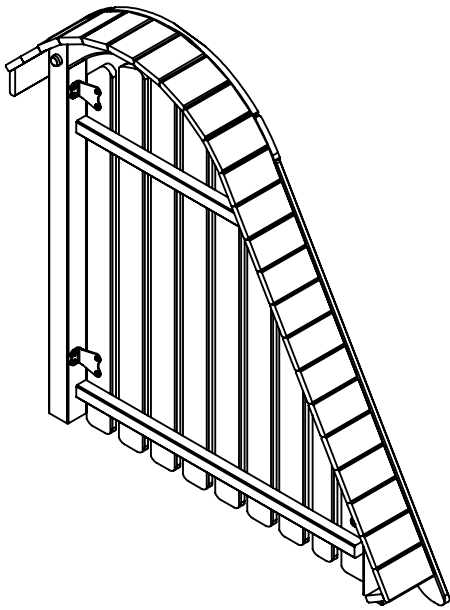

1

Nr	Σ	Element		
2	6		-	W6x60
9	6		ISO 7380	M6x25
21	6		DIN 125	8x16
22	6		DIN 125	6x12
58	1		-	LOCTITE
147	6		-	M6x10
278	3		-	8100_8_A2_g4_G_v3
325	6		9130	6x60
338	3		DIN 9130	6x120

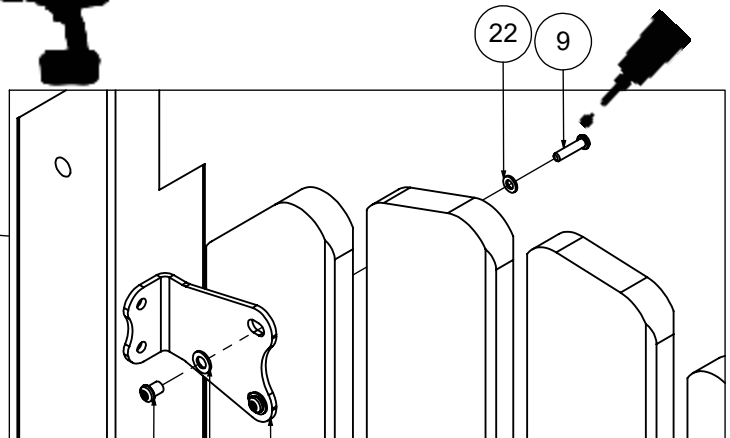
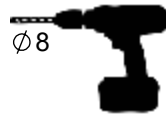
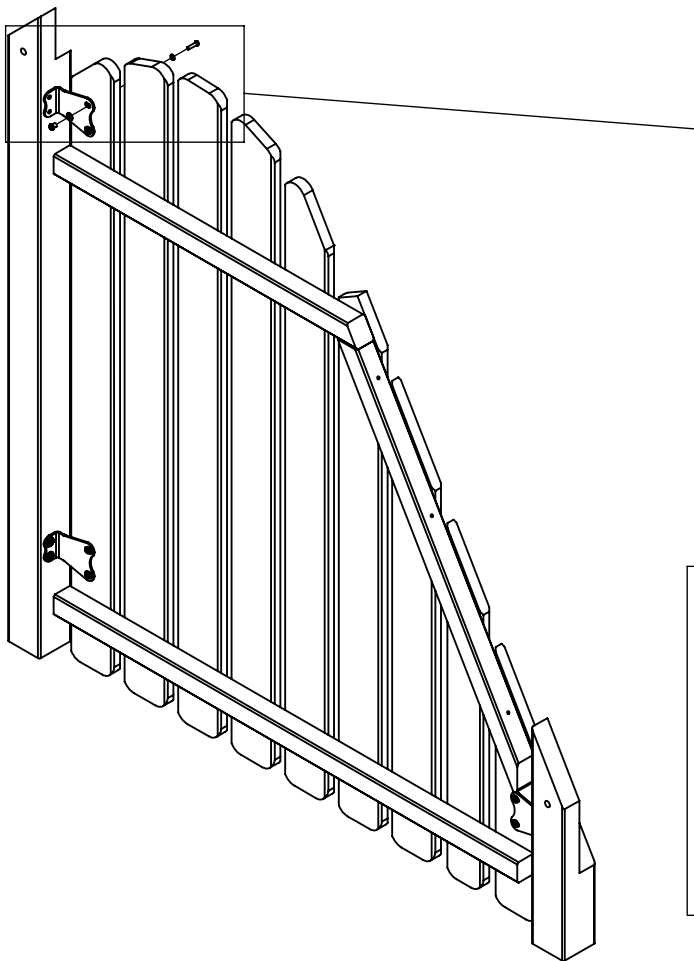

147 21 278

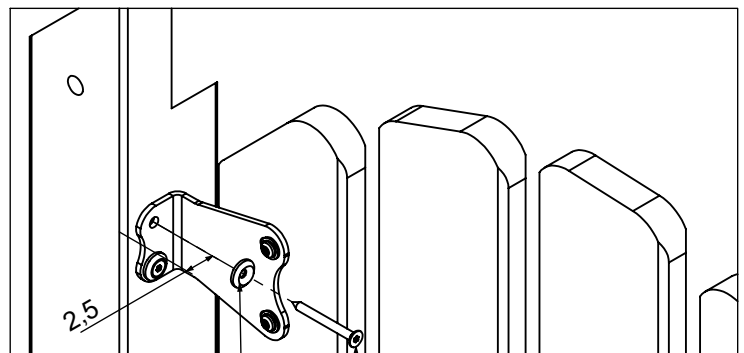
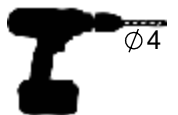
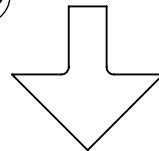



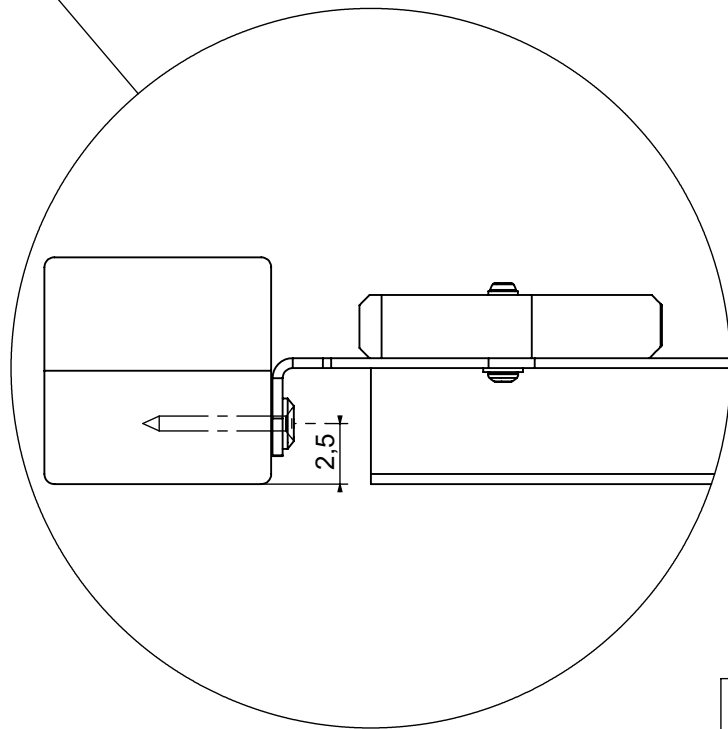
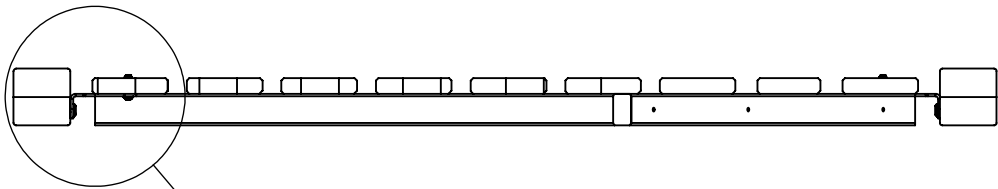
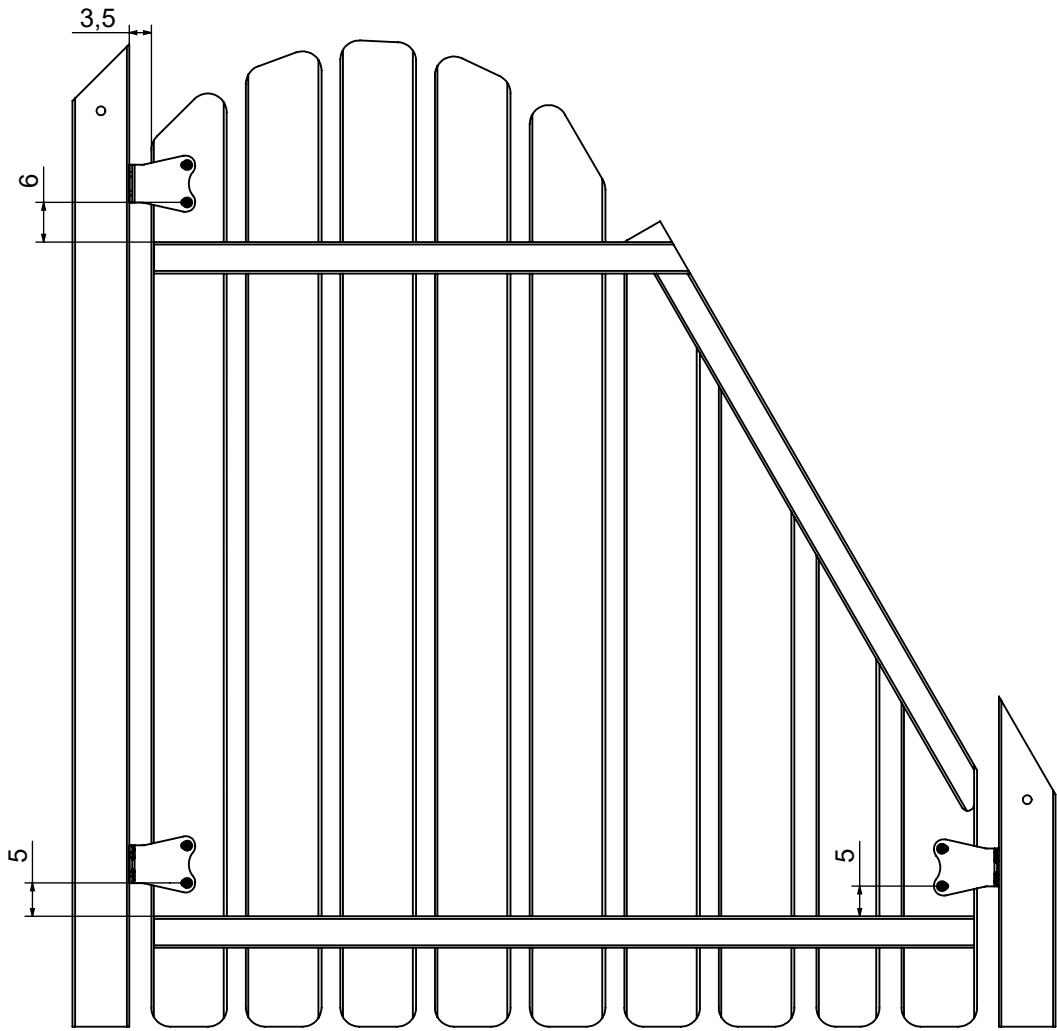



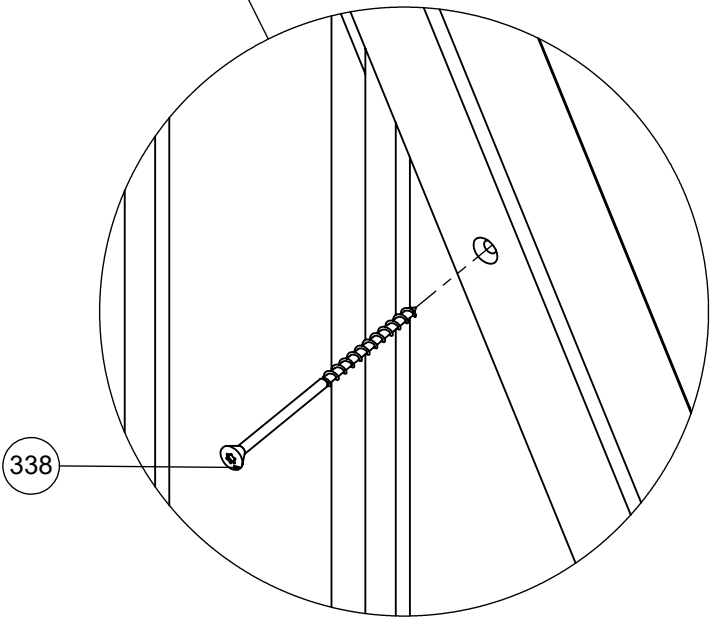
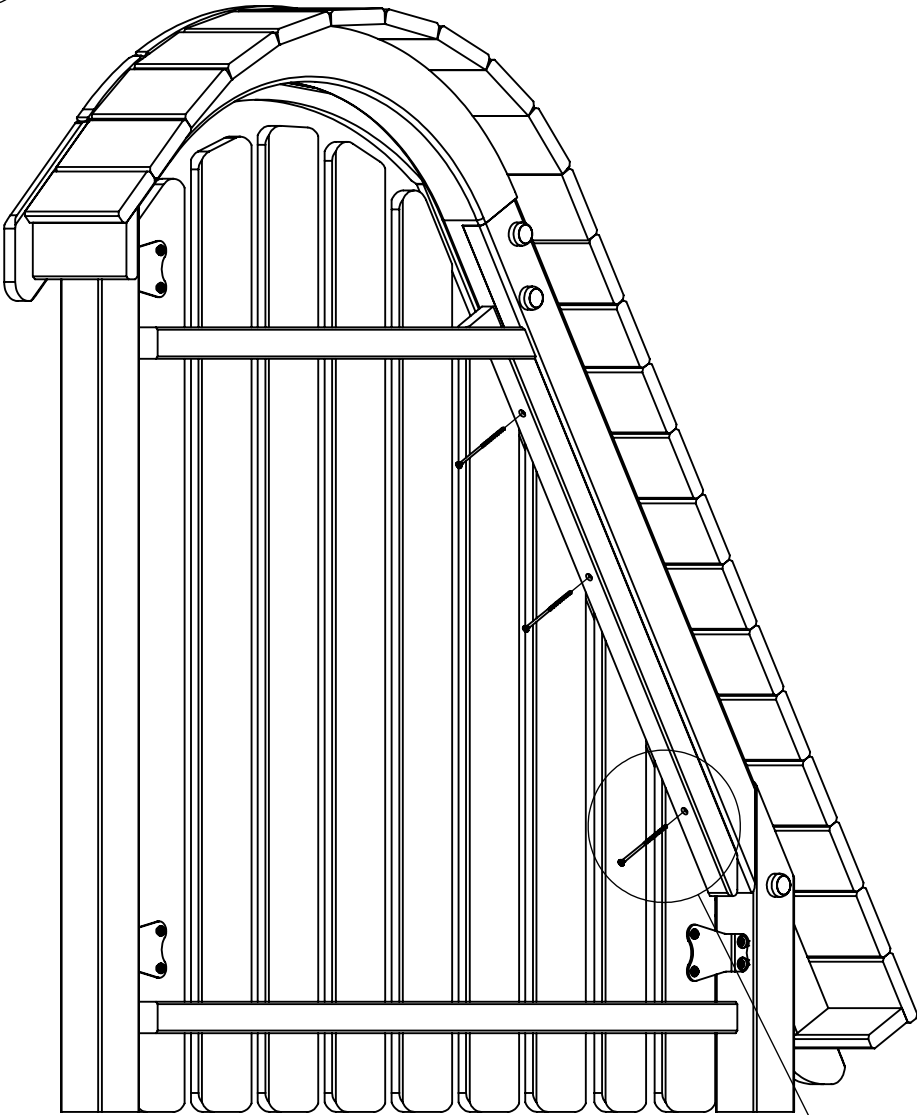



2 325



2

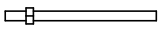

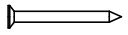
INST_84_1C

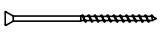
				N	F
Nr	Element	DIN	ELEMENT	Σ	Σ
2		-	W6x60	8	8
9		ISO 7380	M6x25	8	8
21		DIN 125	8x16	10	10
22		DIN 125	6x12	10	10
51		ISO 7380	M6x45	2	2
58		-	LOCTITE	1	1
61		-	KL105 (OC)		2
147		-	M6x10	10	10
269		-	WT 5x60	2	2
278		-	8100_8_A2_g4_G_v3	4	4
325		9130	6x60	8	8
338		DIN 9130	6x120	3	3

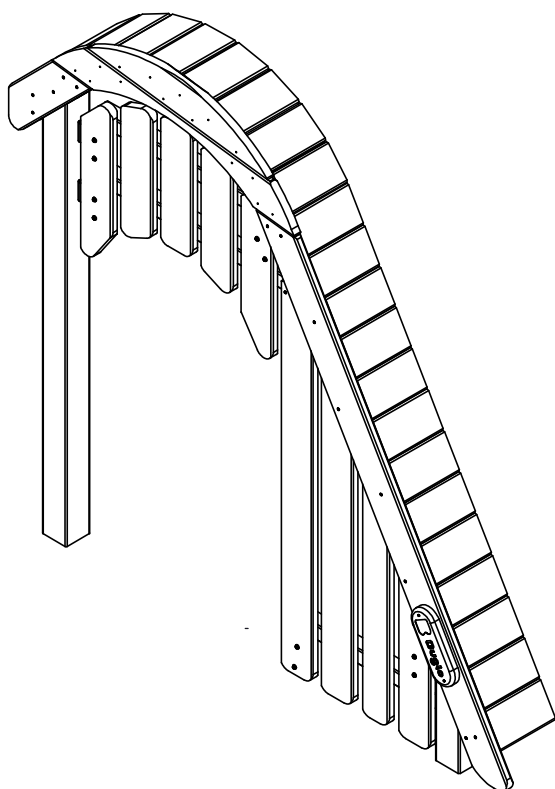

1 N

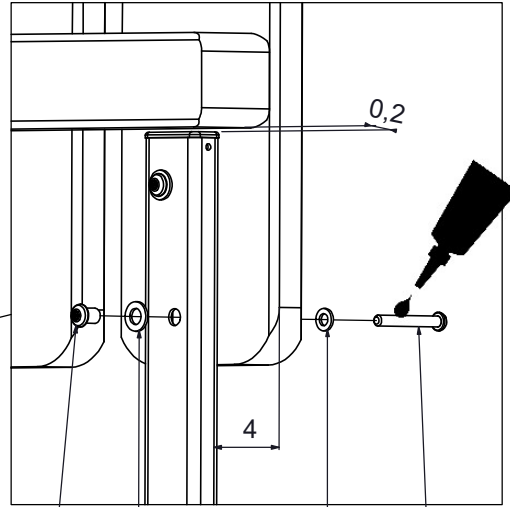
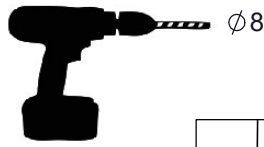
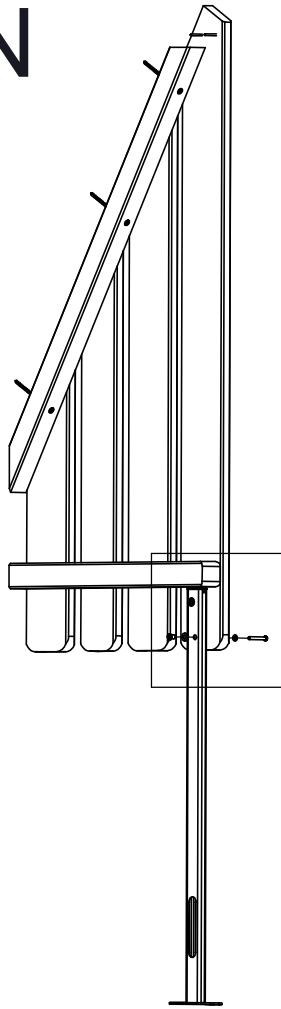

147 21 22 51

1 F

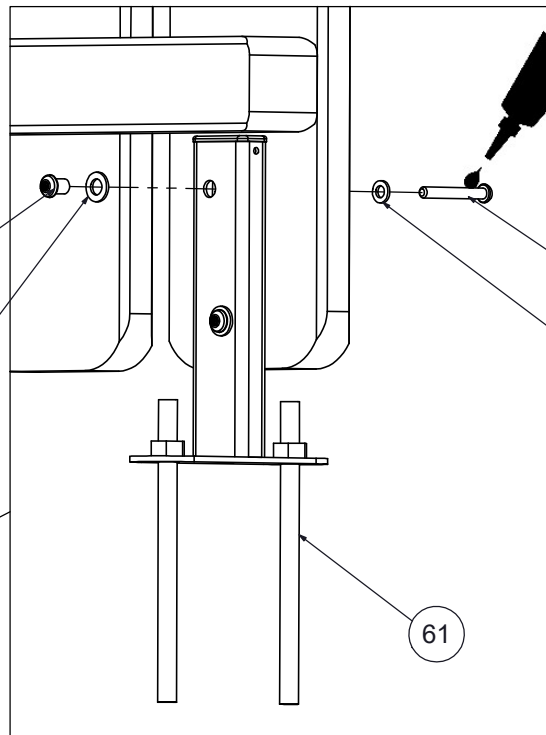
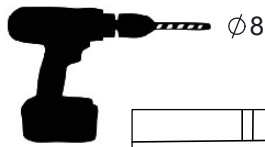
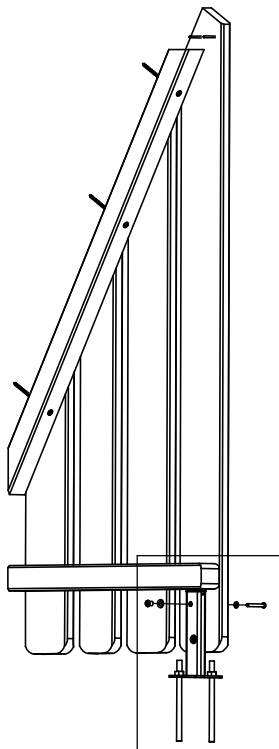

147 21 51 22 61

2

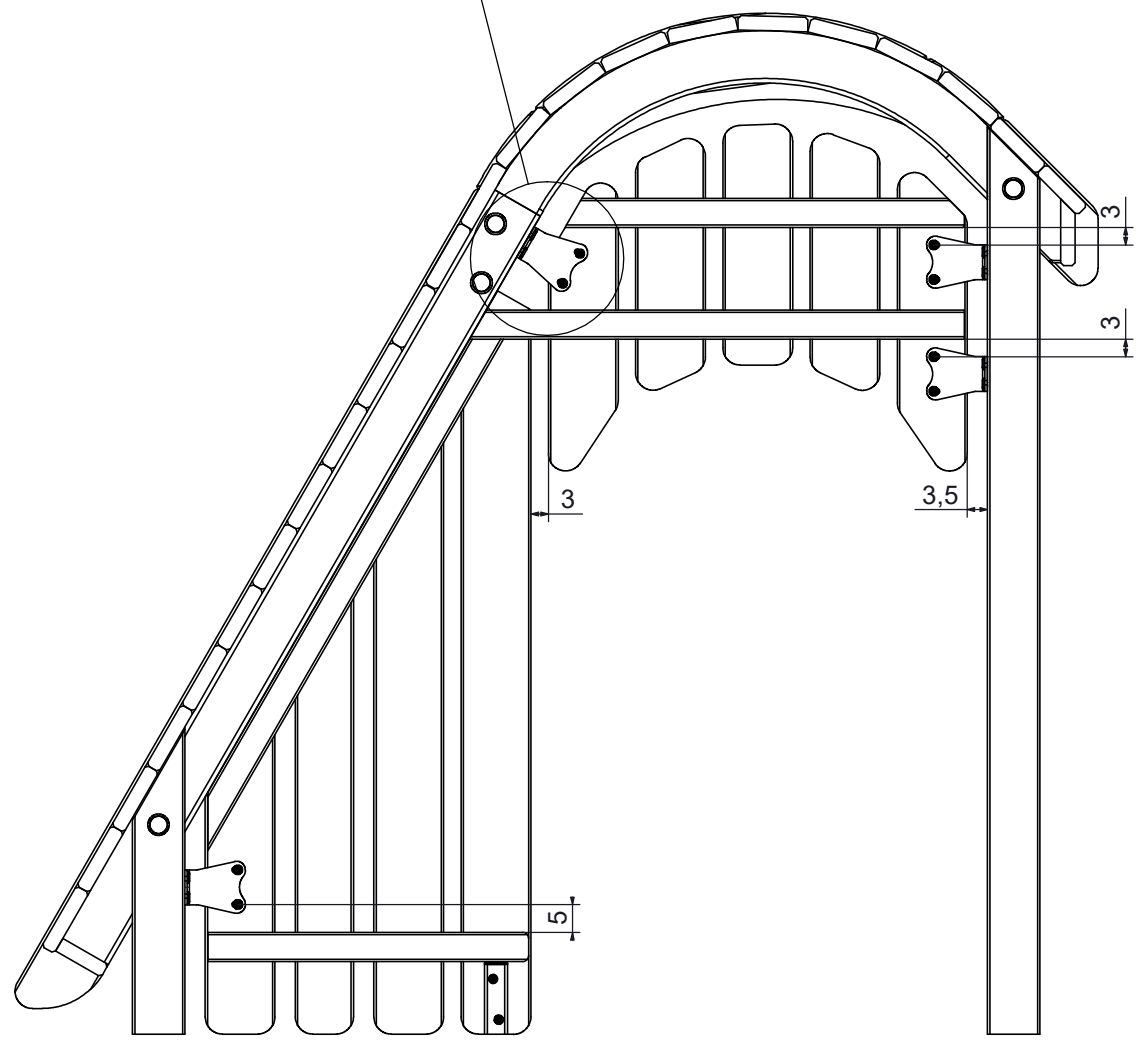
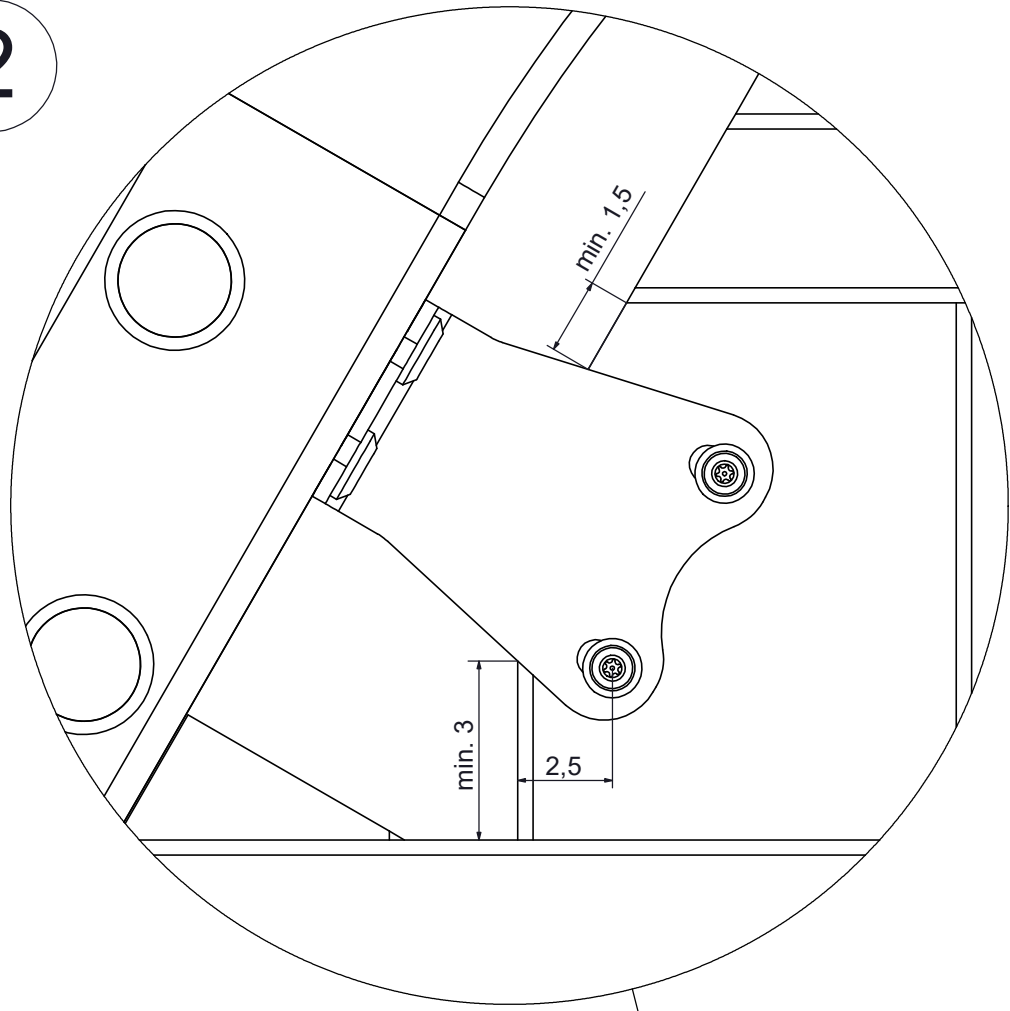

2

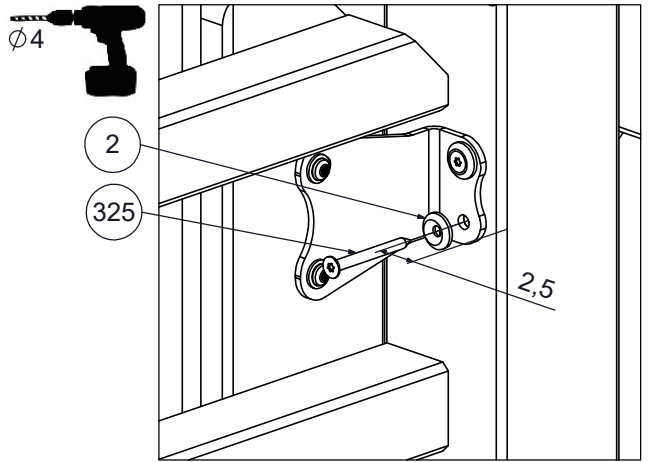
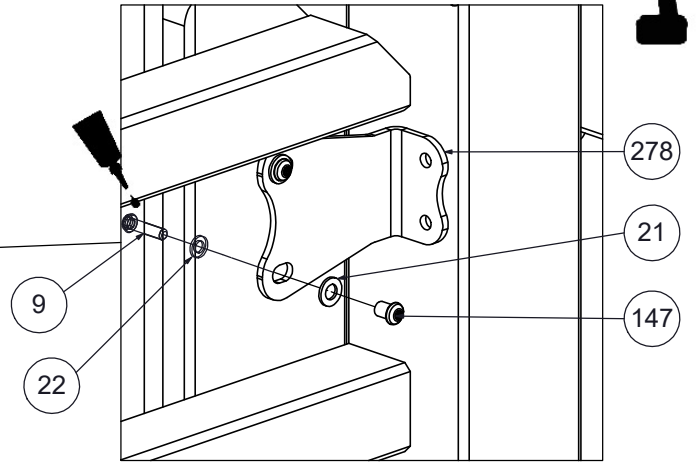
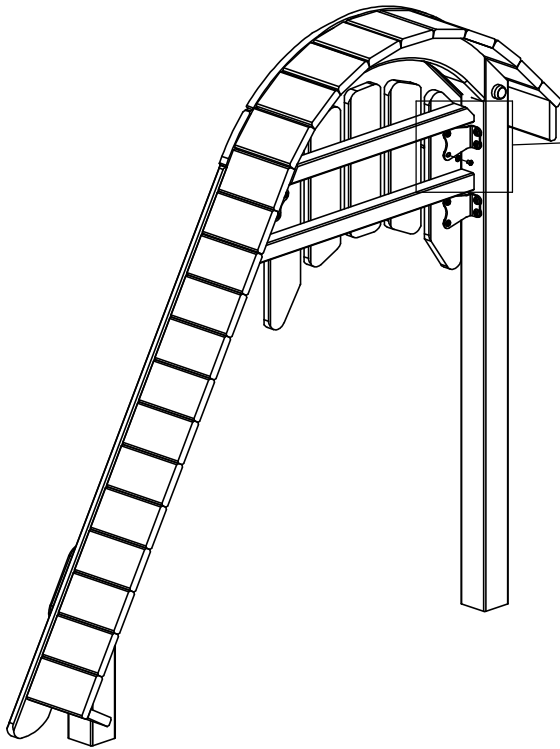

3

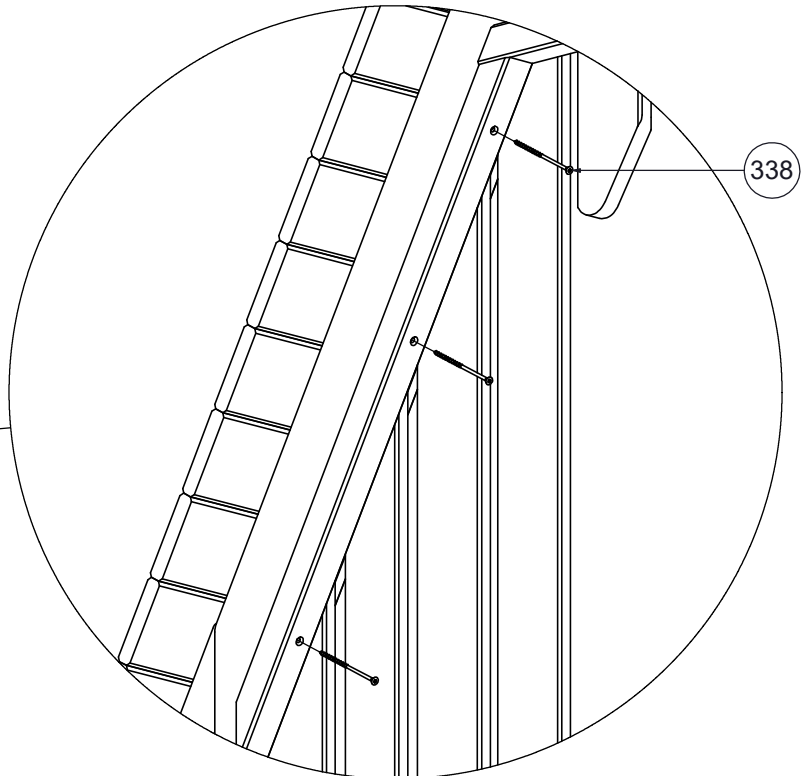
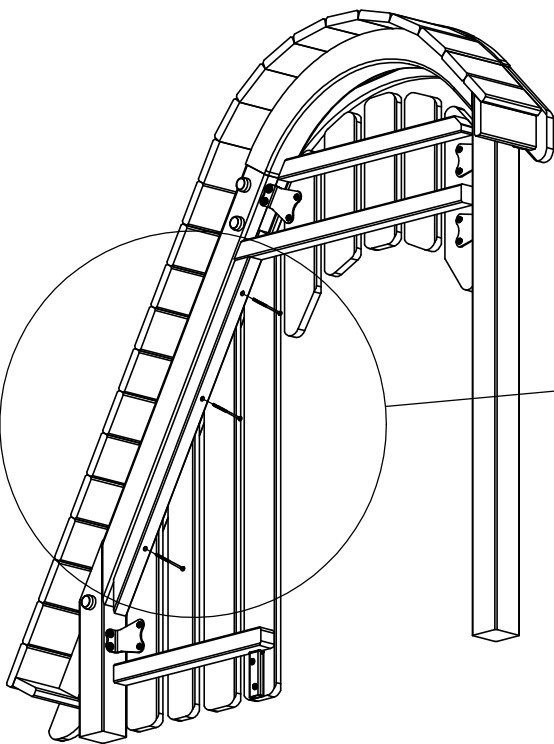

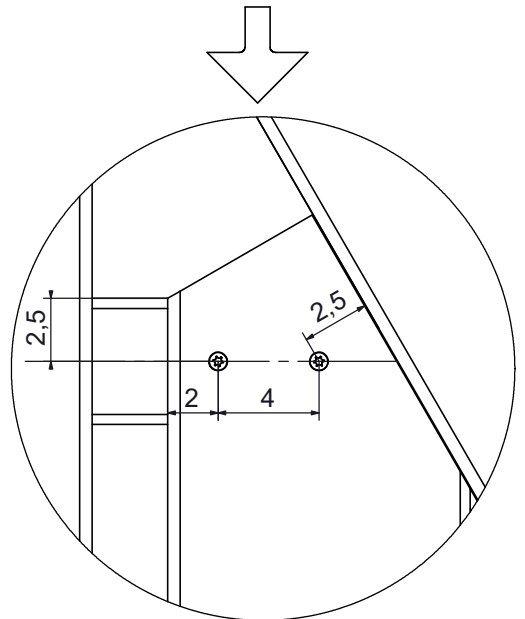
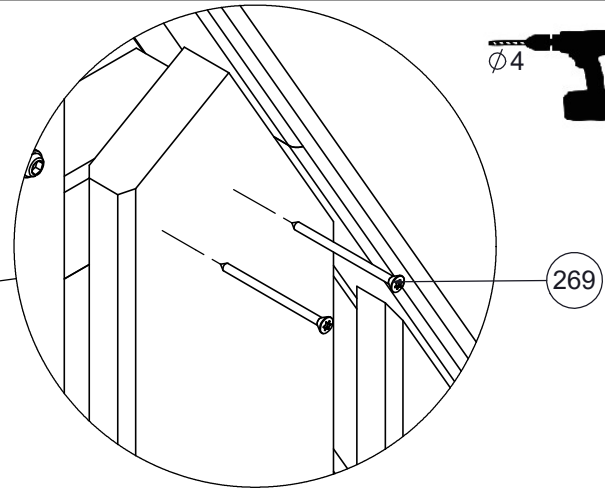
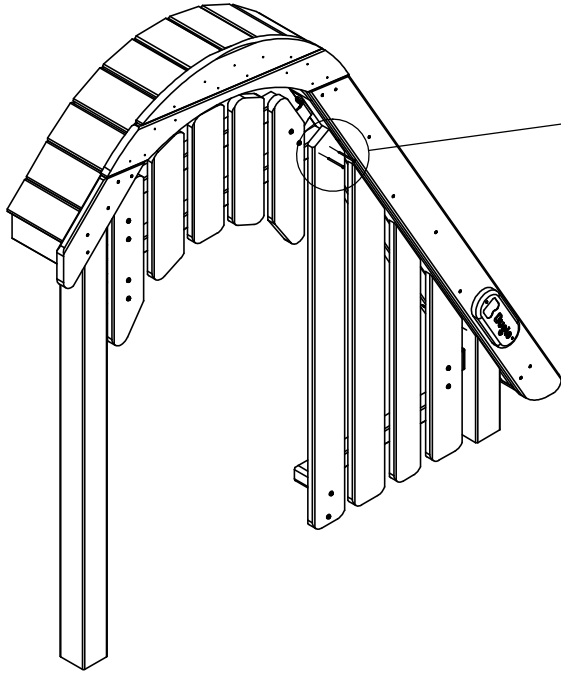

4

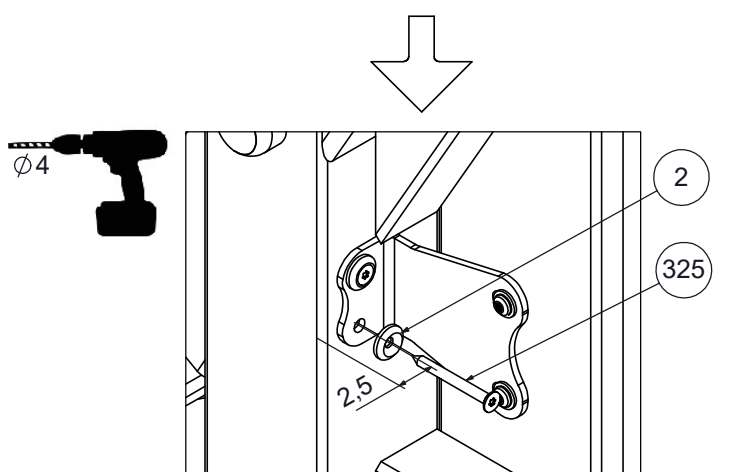
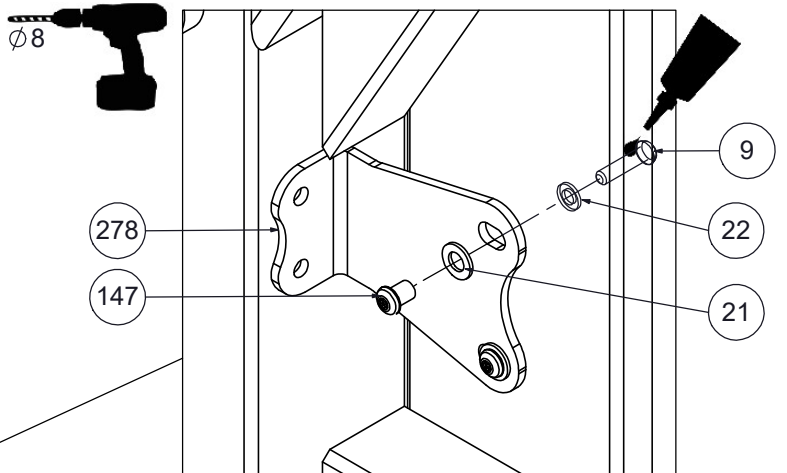
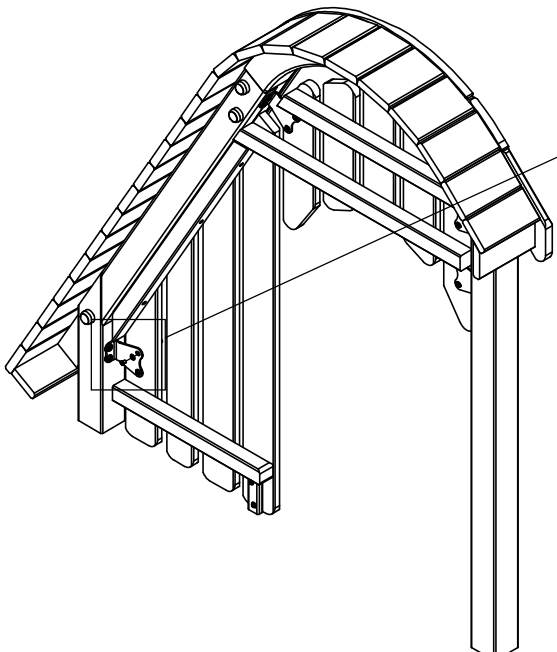

5

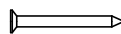

INST_84_2

Nr	Σ	Element		
1	8		-	S6x60
22	8		DIN 125	6x12
325	6		9130	6x60

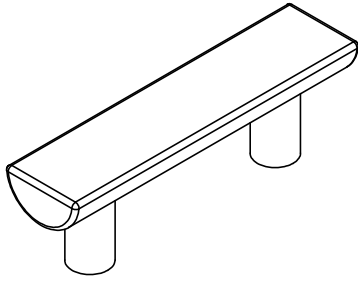

1

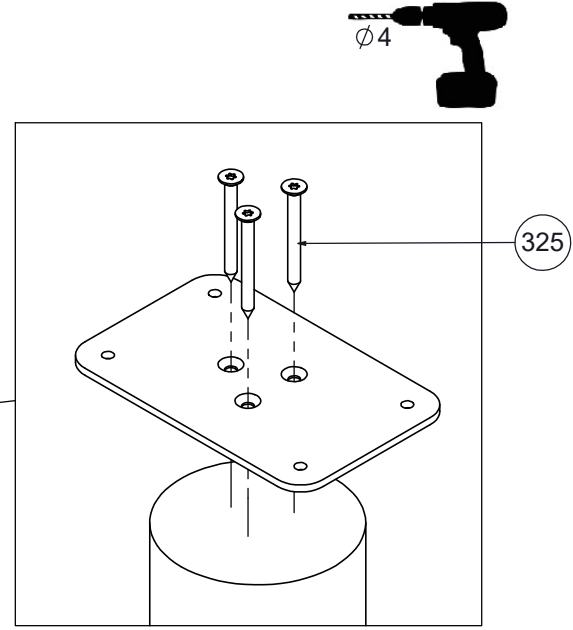
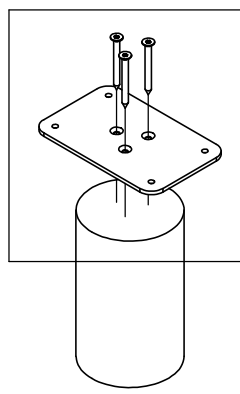
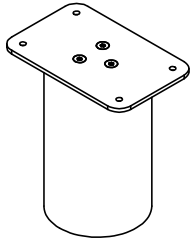

2

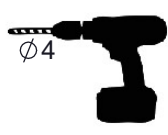
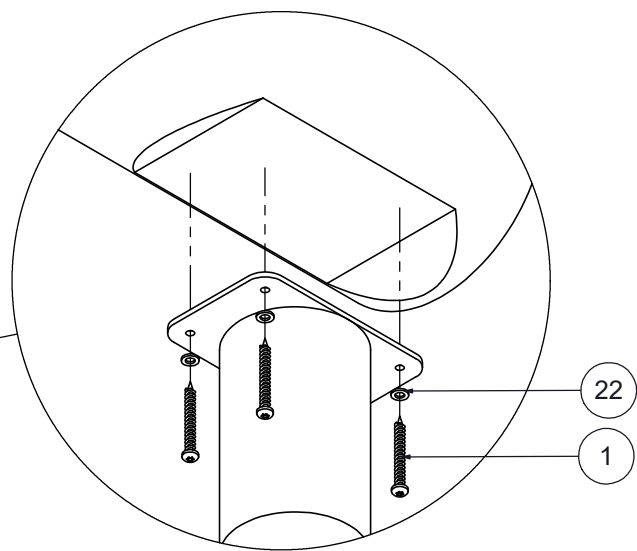
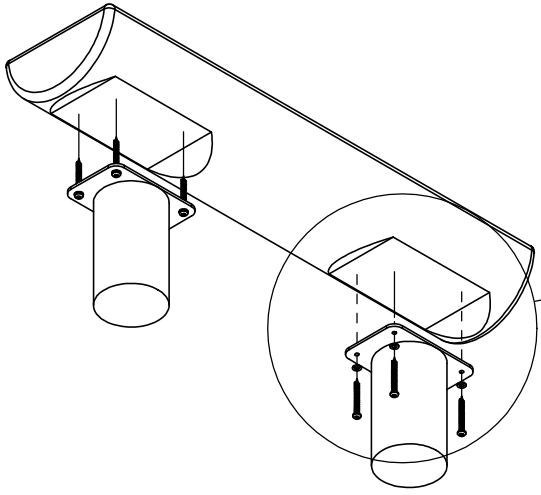



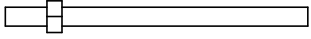
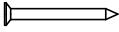

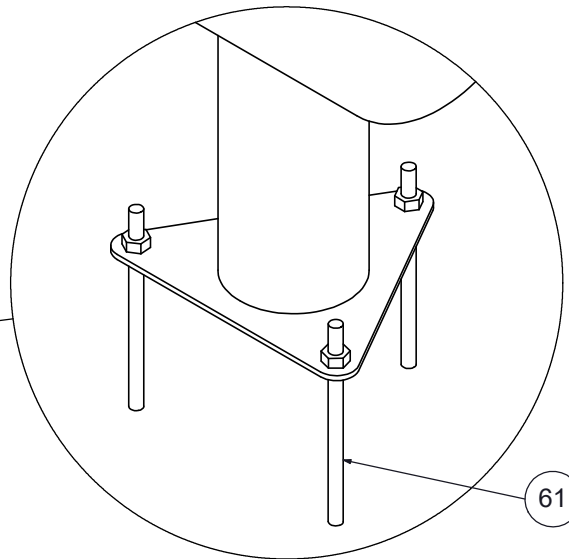
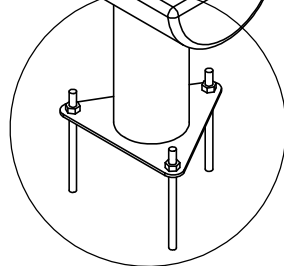
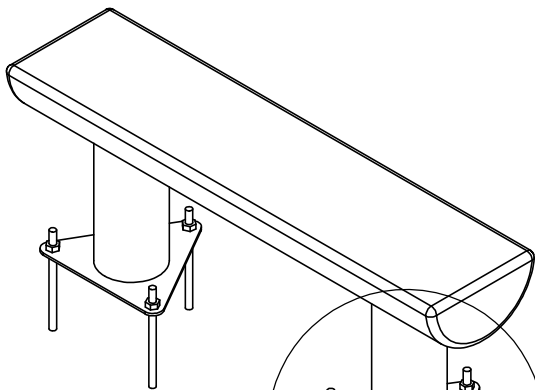
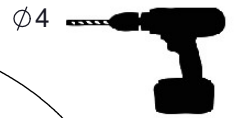
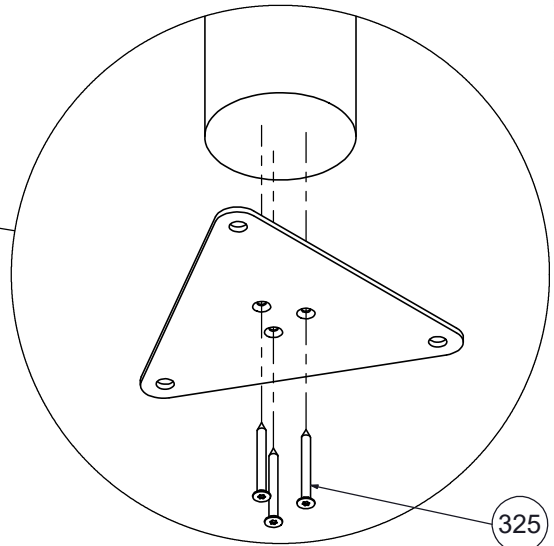
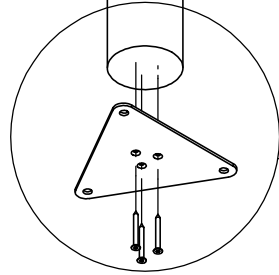
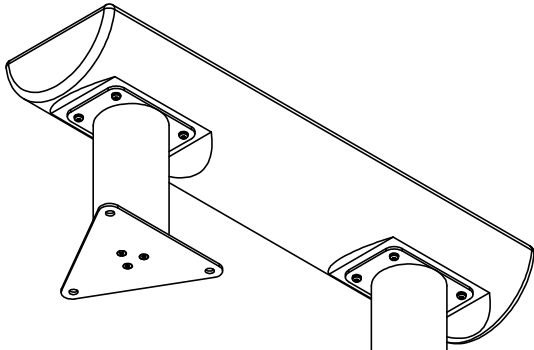

3 F

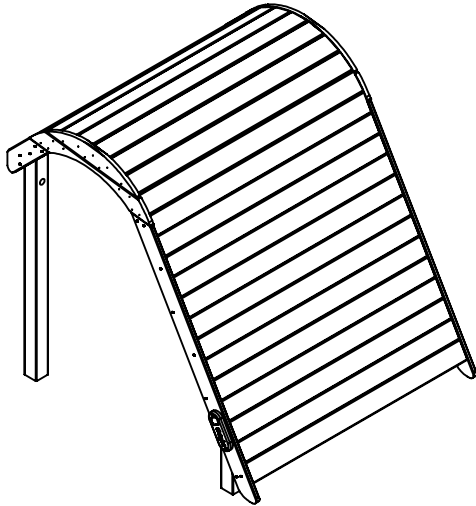
Nr	Σ	Element		
61	6		-	KL105 (OC)
325	6		9130	6x60



INST_84_3

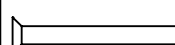

Nr	Σ	Element		
3	10		-	K2_d30_B
6	10		-	Z2_d30_B
63	10		DIN 125	12x24
74	10		DIN 985	M12 (OC)
269	30		-	WT 5x60
599	10		DIN 7991	M12x110

1

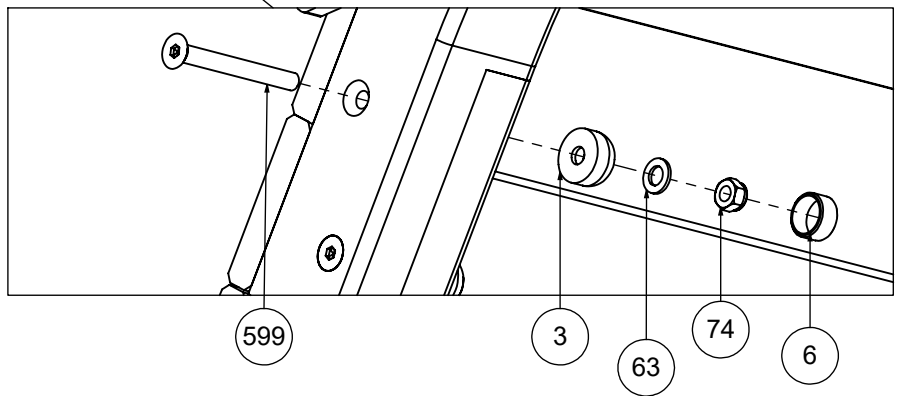
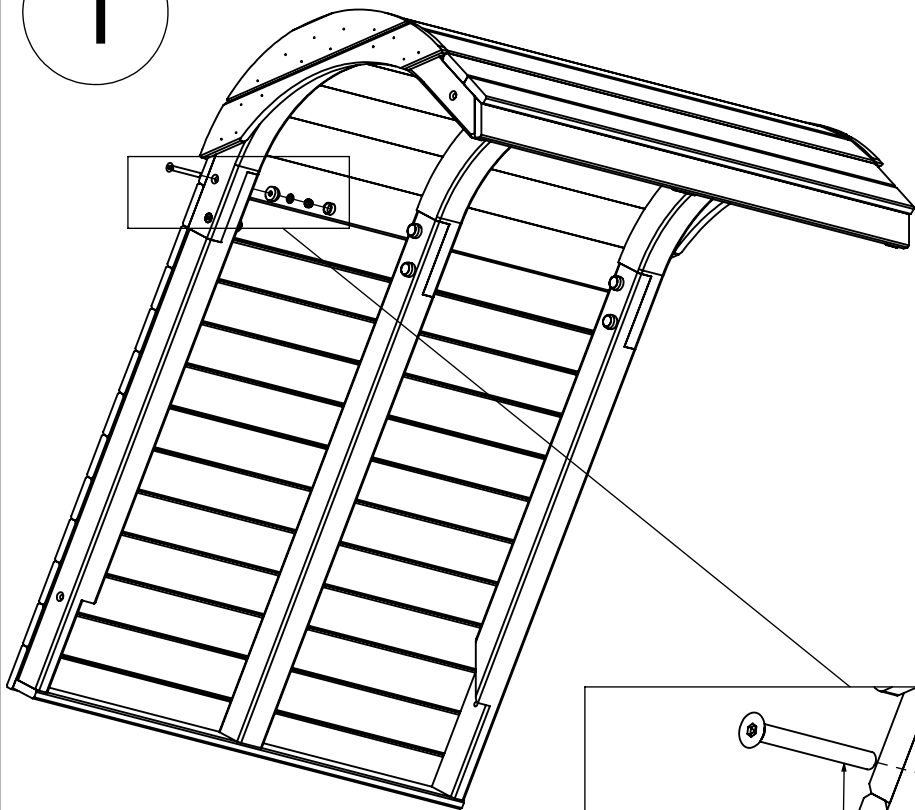

599

3

63

74

6

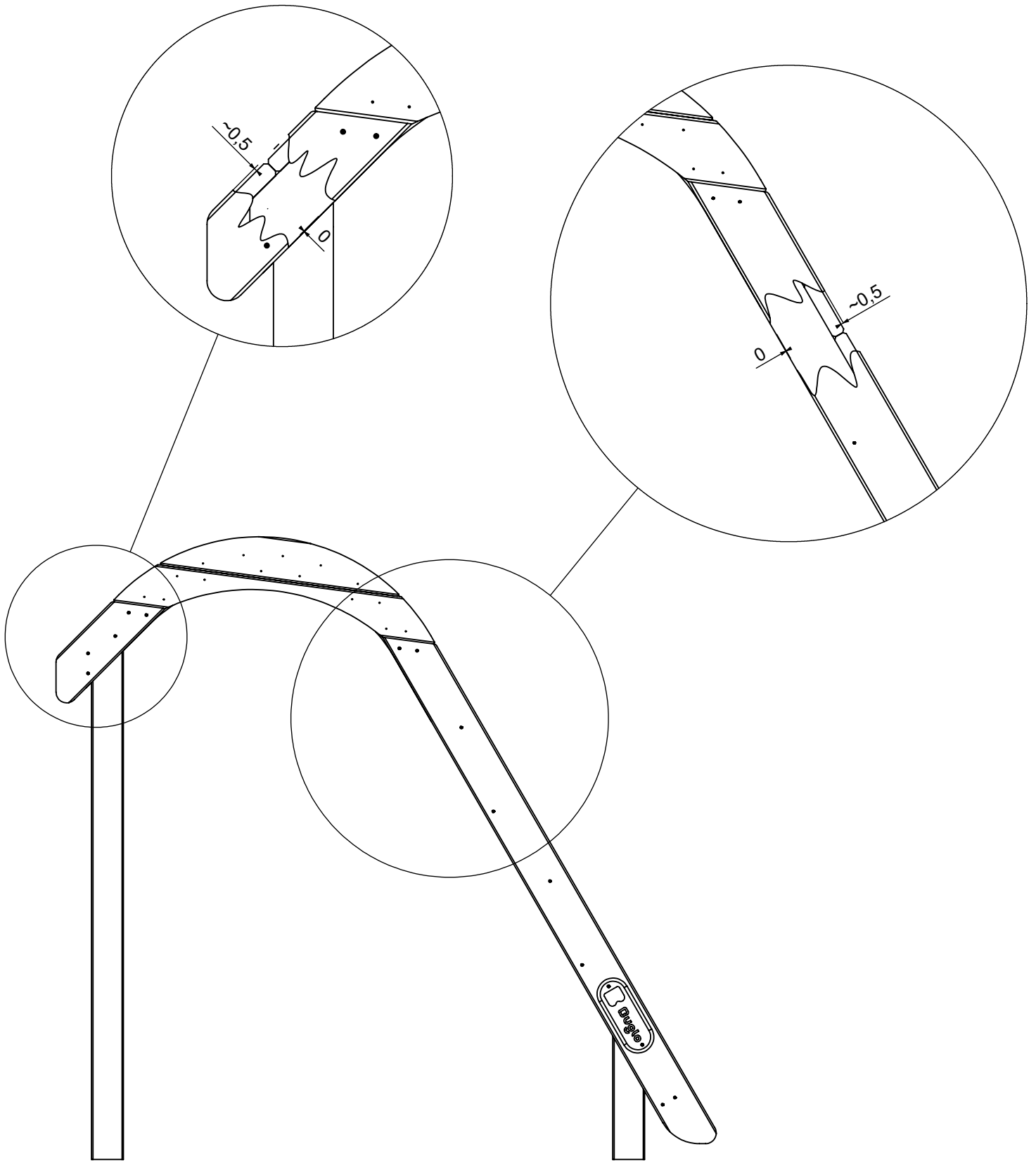

2

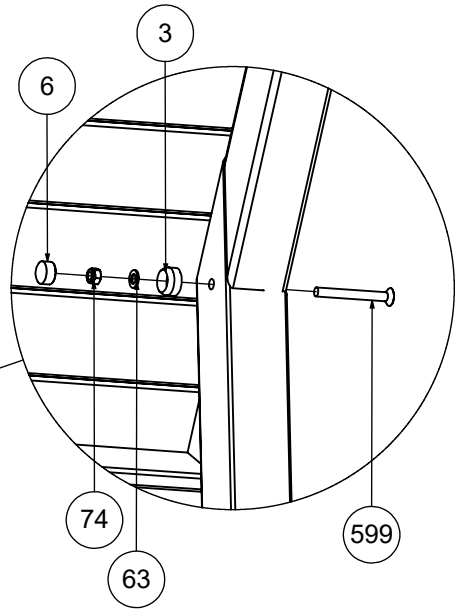
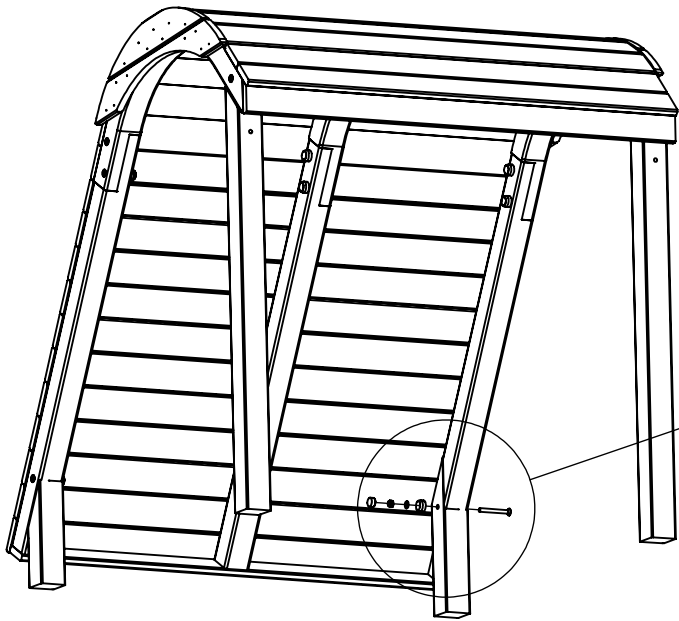

3

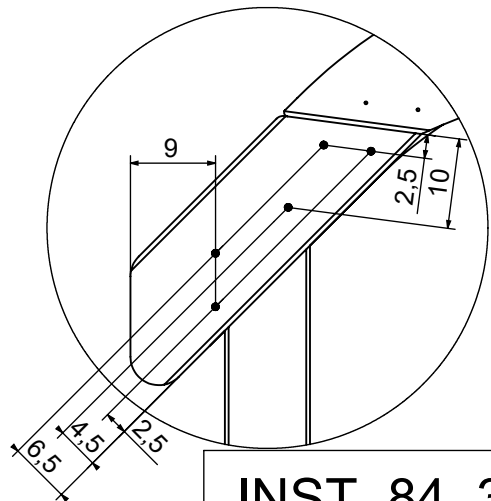
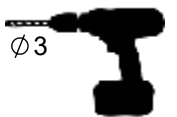
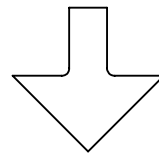
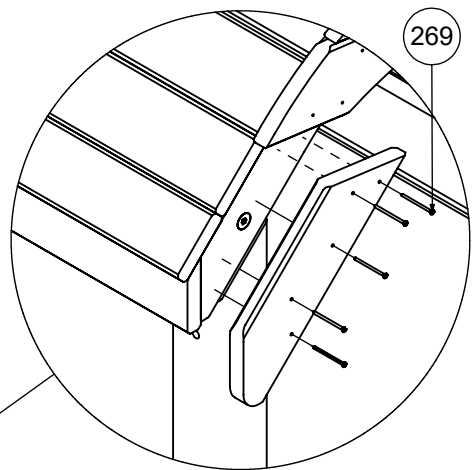
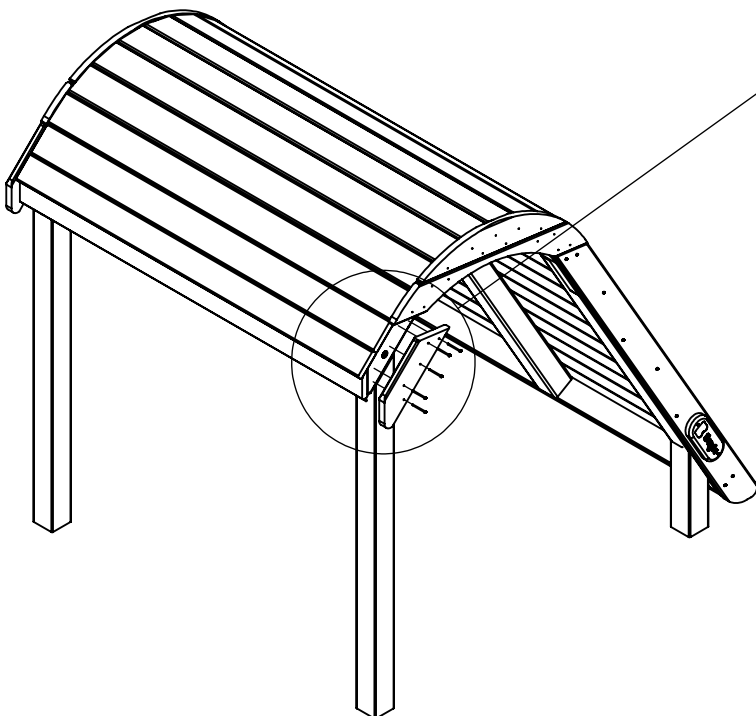

INST_84_3 3/5

4

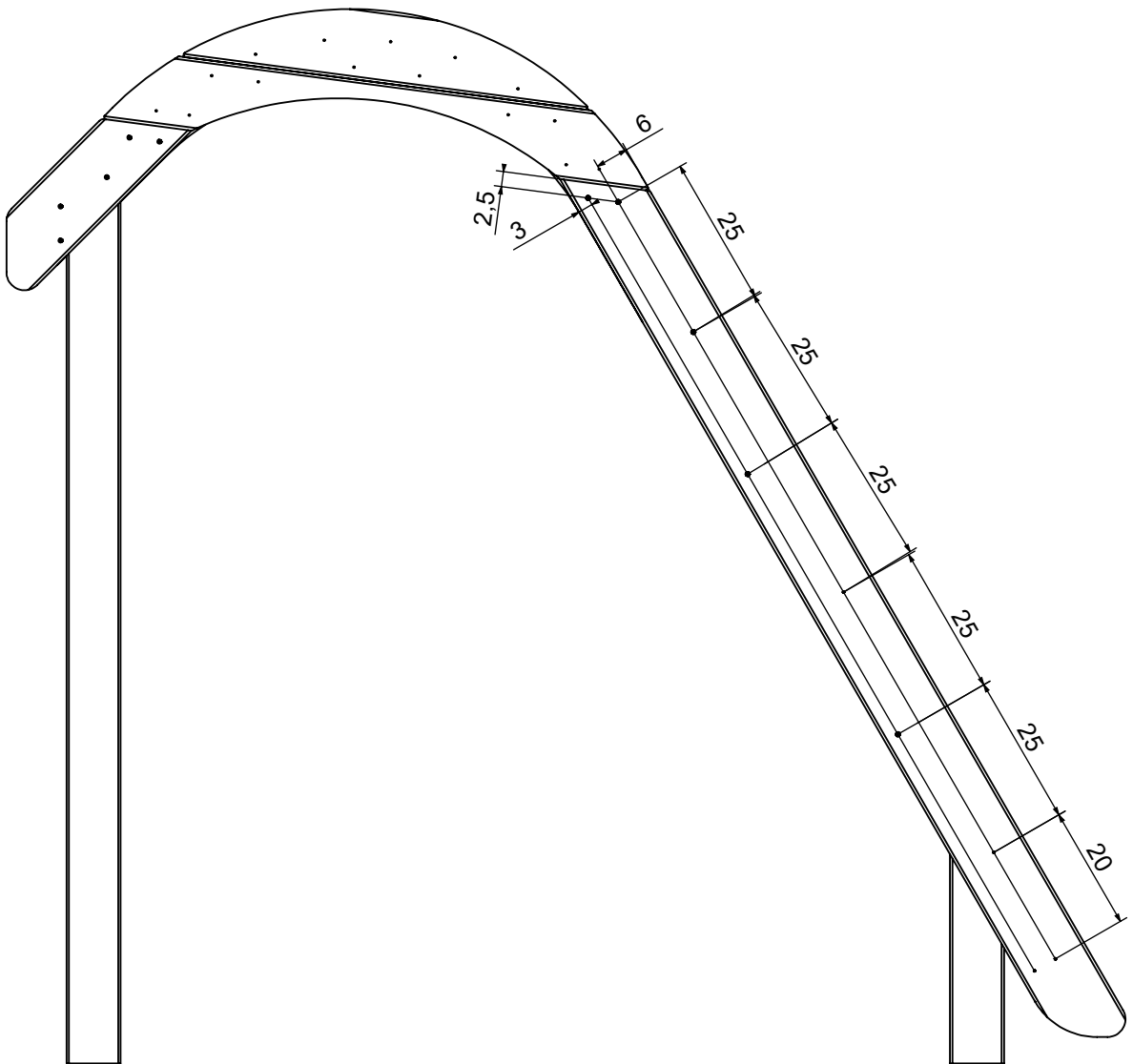
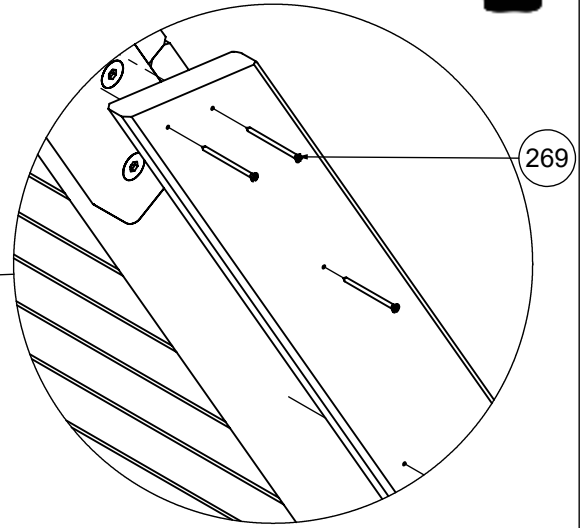
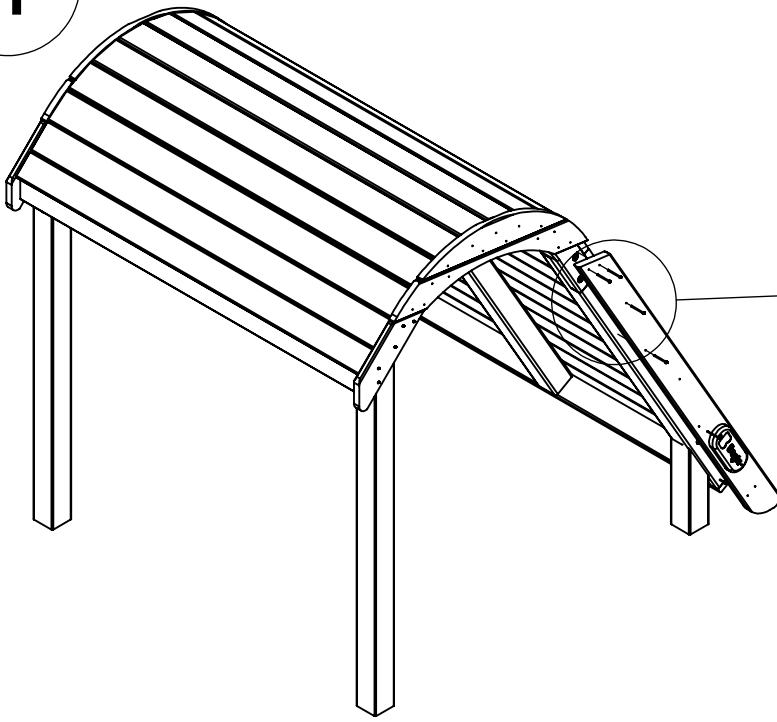
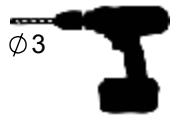



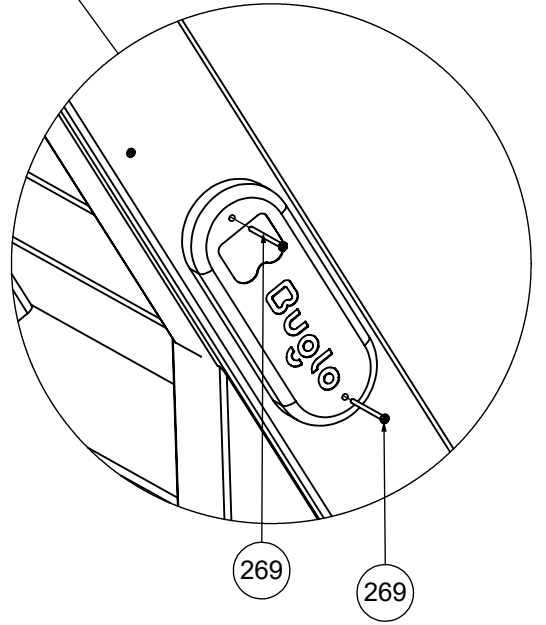
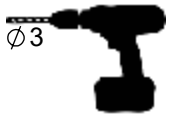
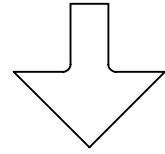
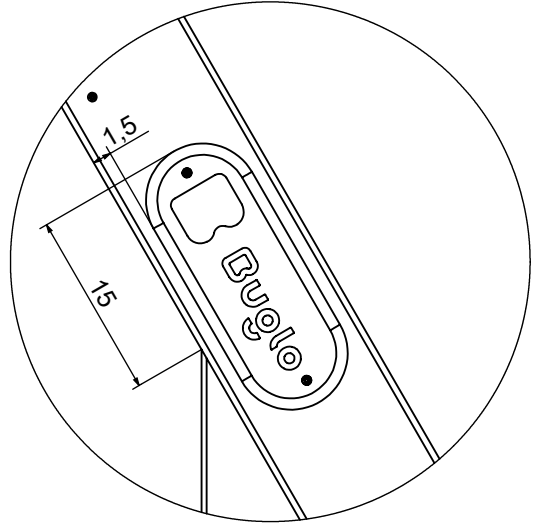
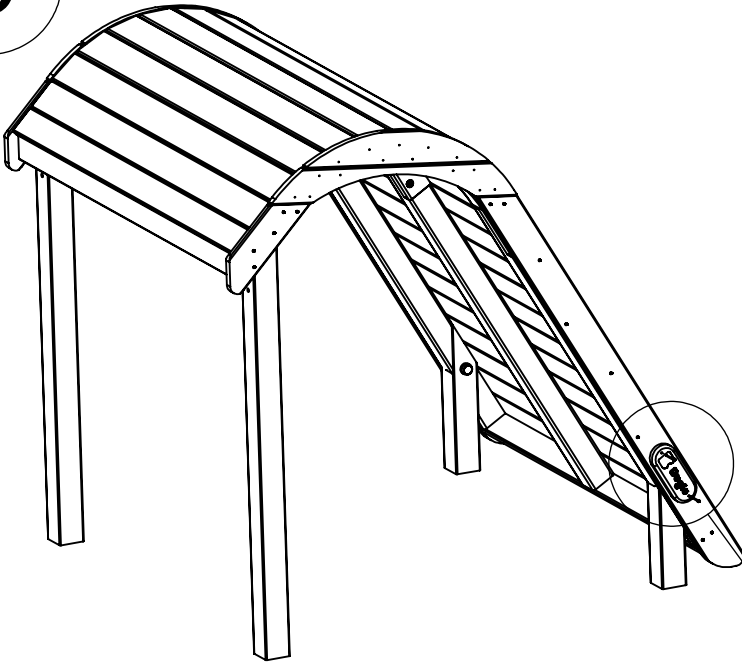

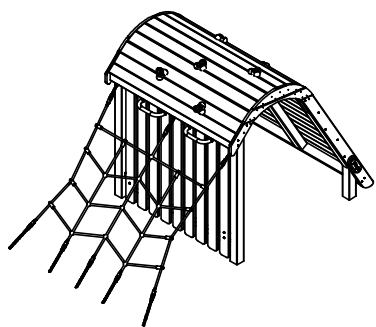

5



INST_84_4A

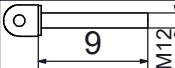

Nr	Σ	Element		
21	4		DIN 125	8x16
58	1		-	LOCTITE
63	2		DIN 125	12x24
74	2		DIN 985	M12
132	4		DIN 7991	M6x25
147	4		-	M6x10
229	2		-	Z_R_42
600	2		-	S62_8100_0

1

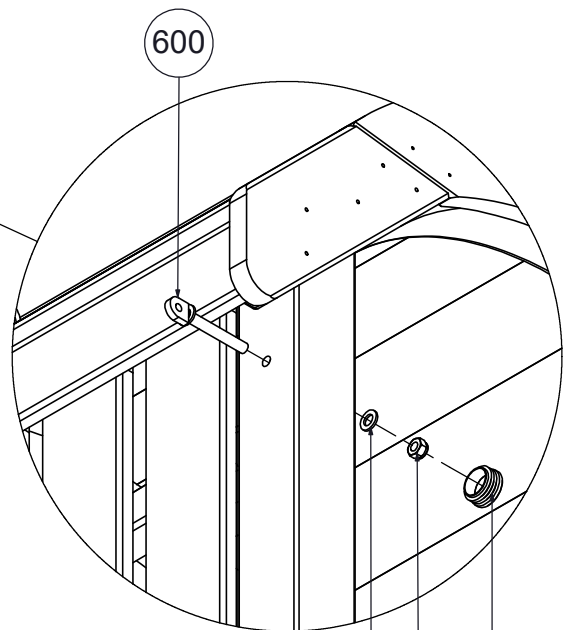
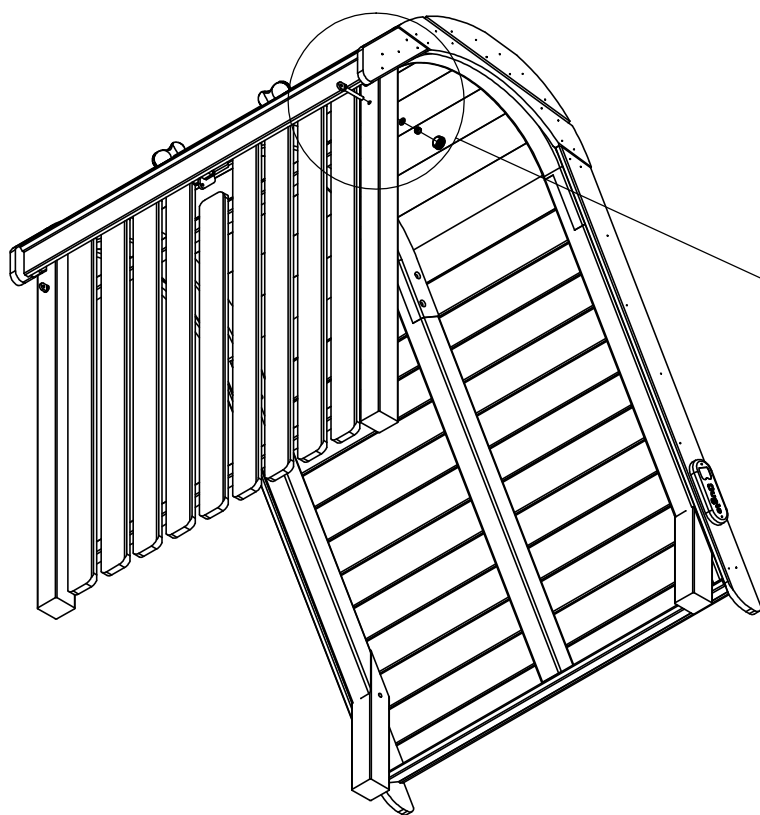

600
63
229
74

2

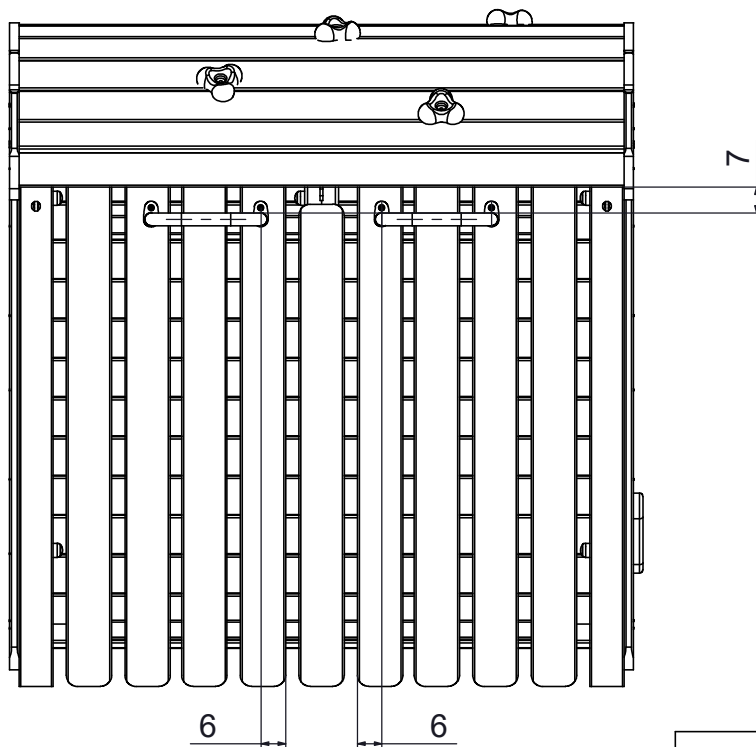
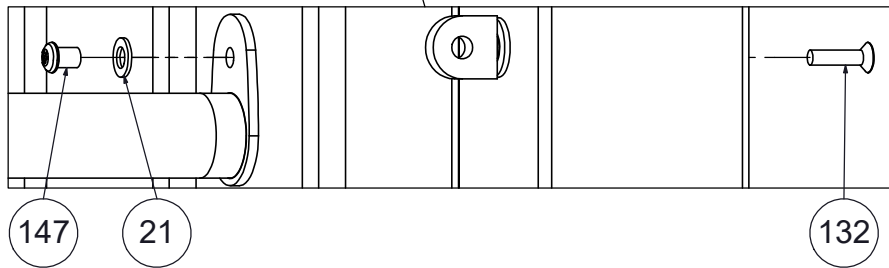
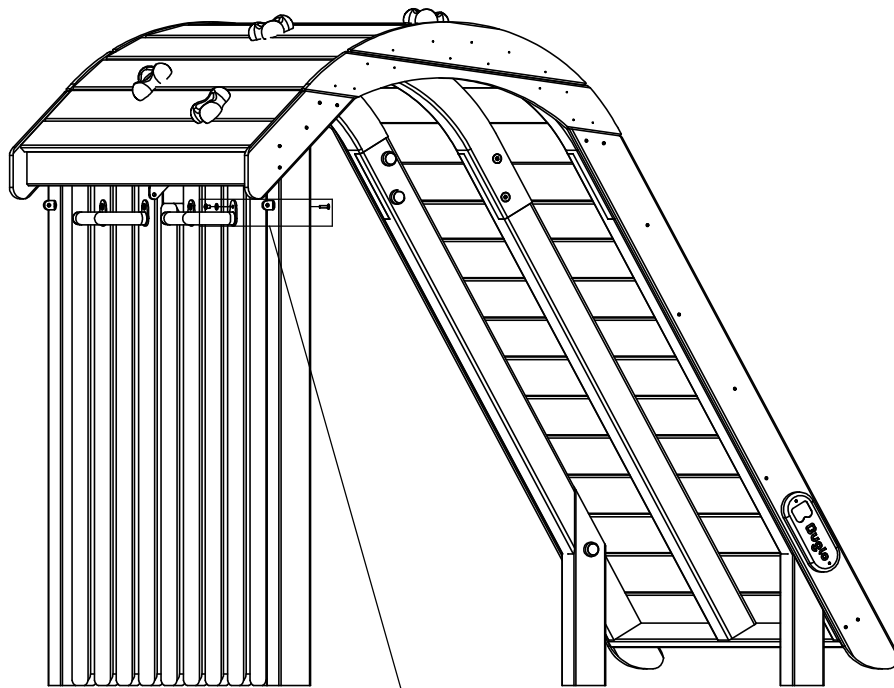

3

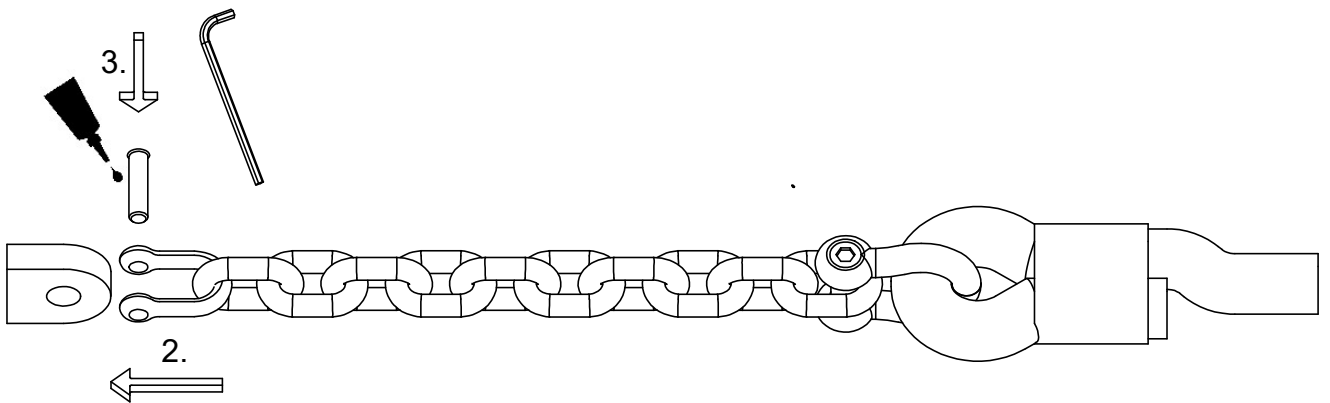
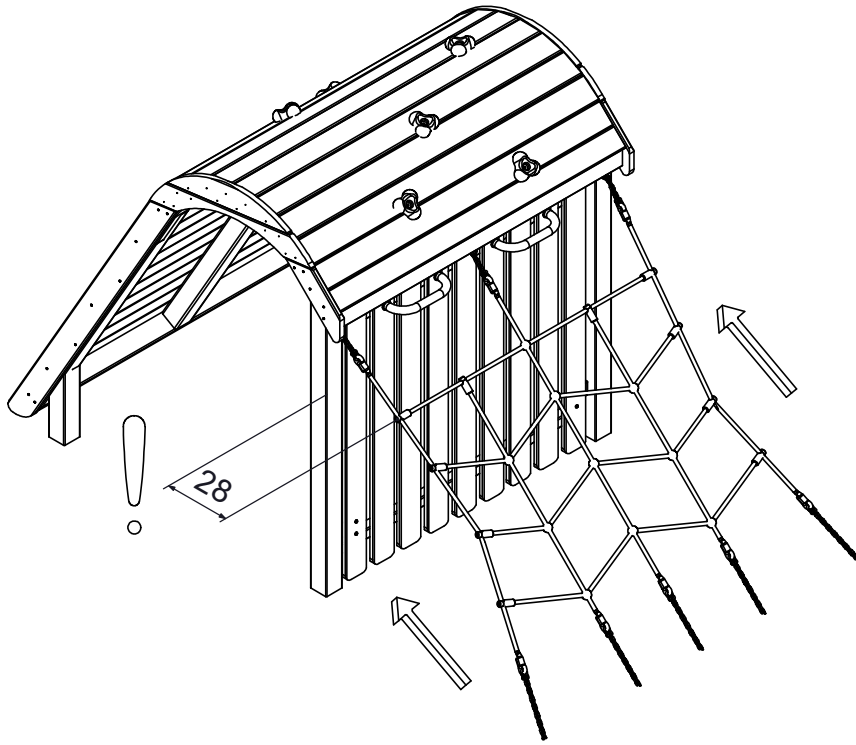
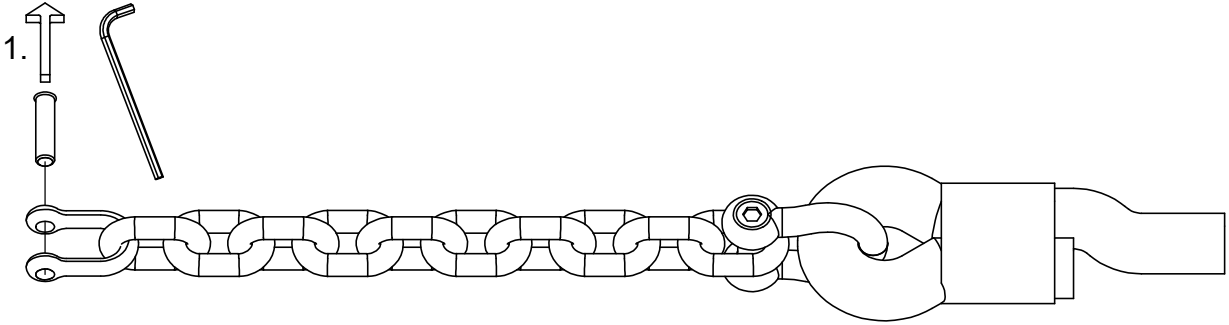

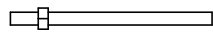
Nr	Σ	Element		
61	15		-	KL105 (OC)

3 F

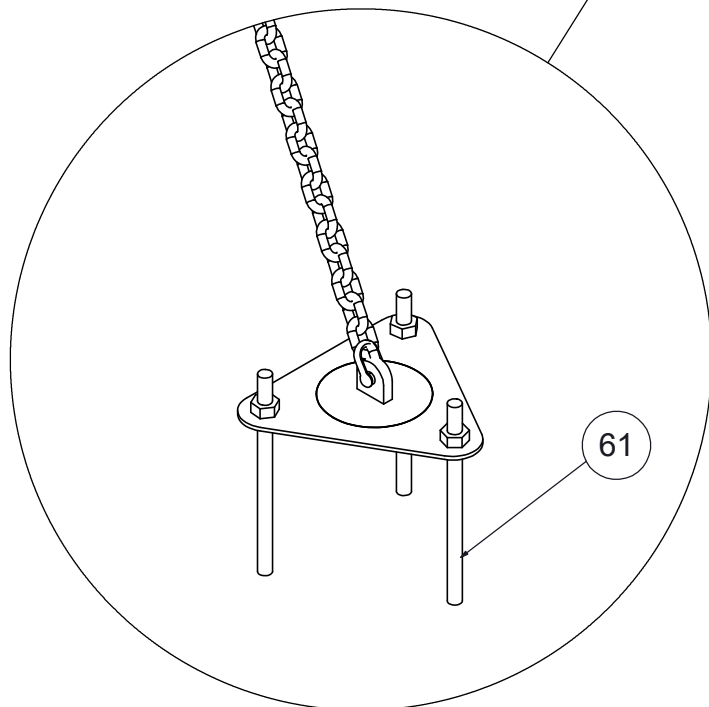
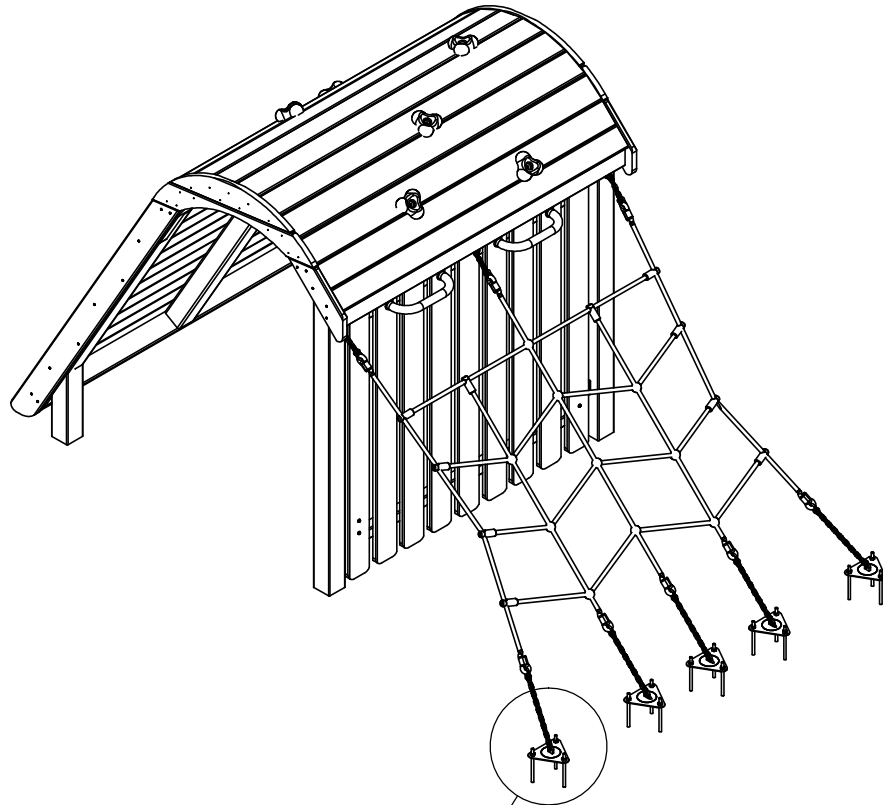

INST_84_12

1

∅6

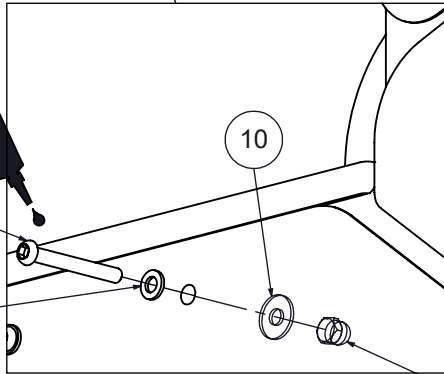
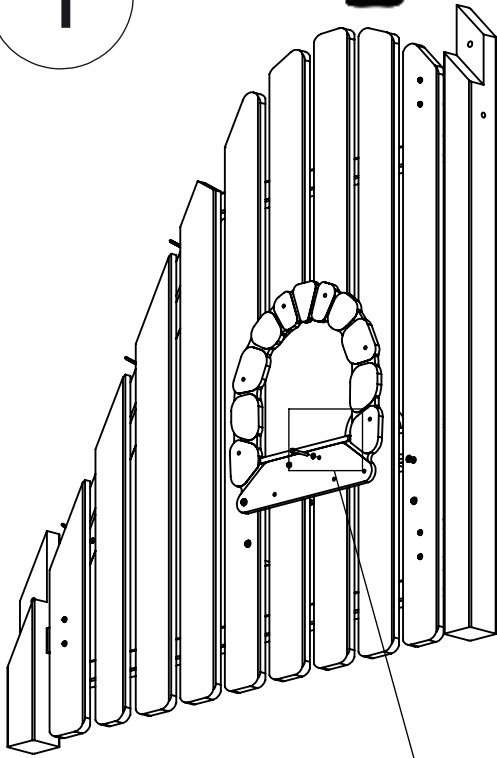

2

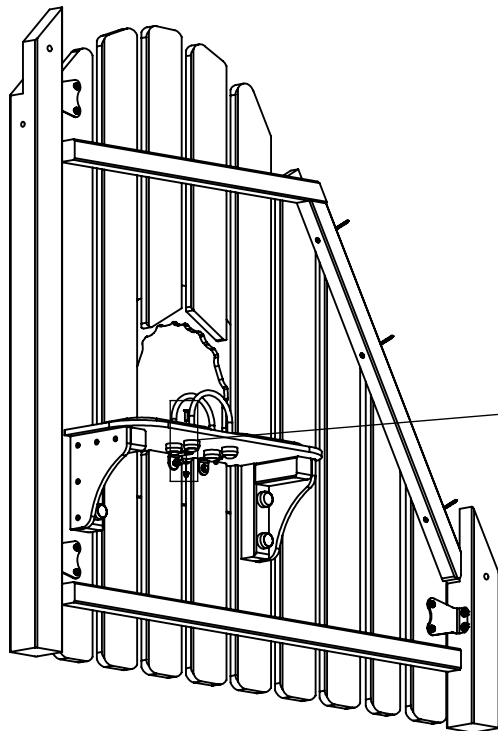

11

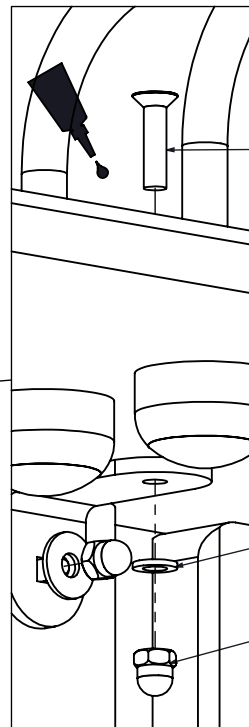

∅6



132

22

11





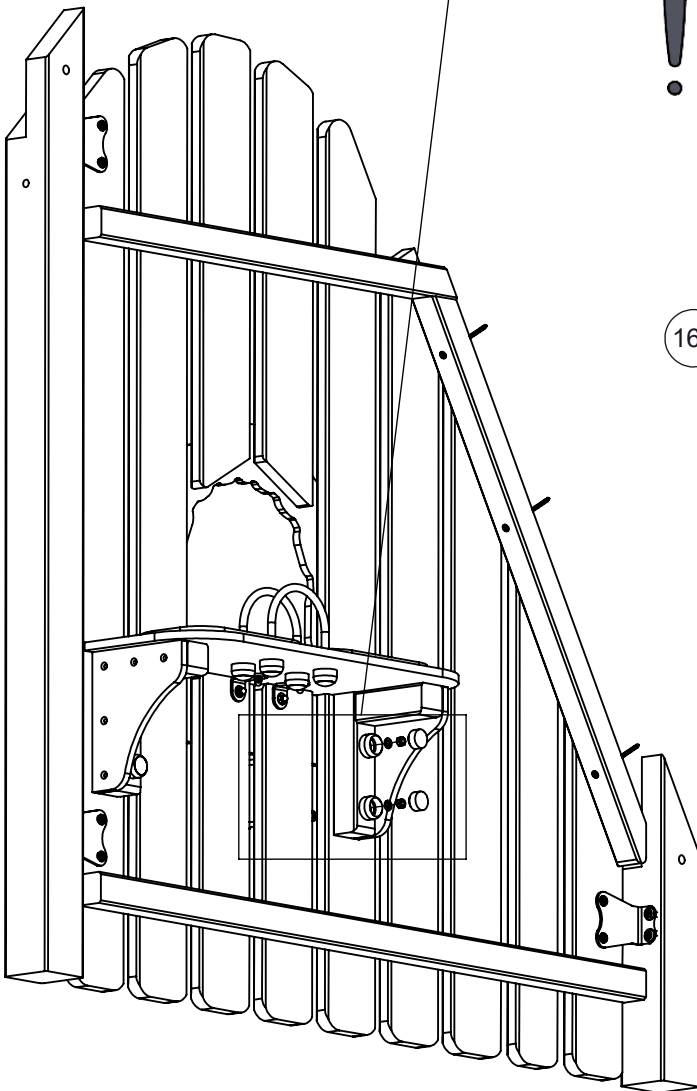
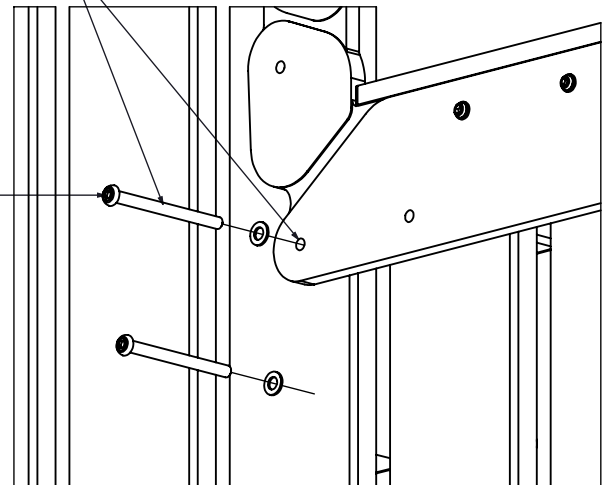
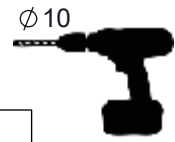
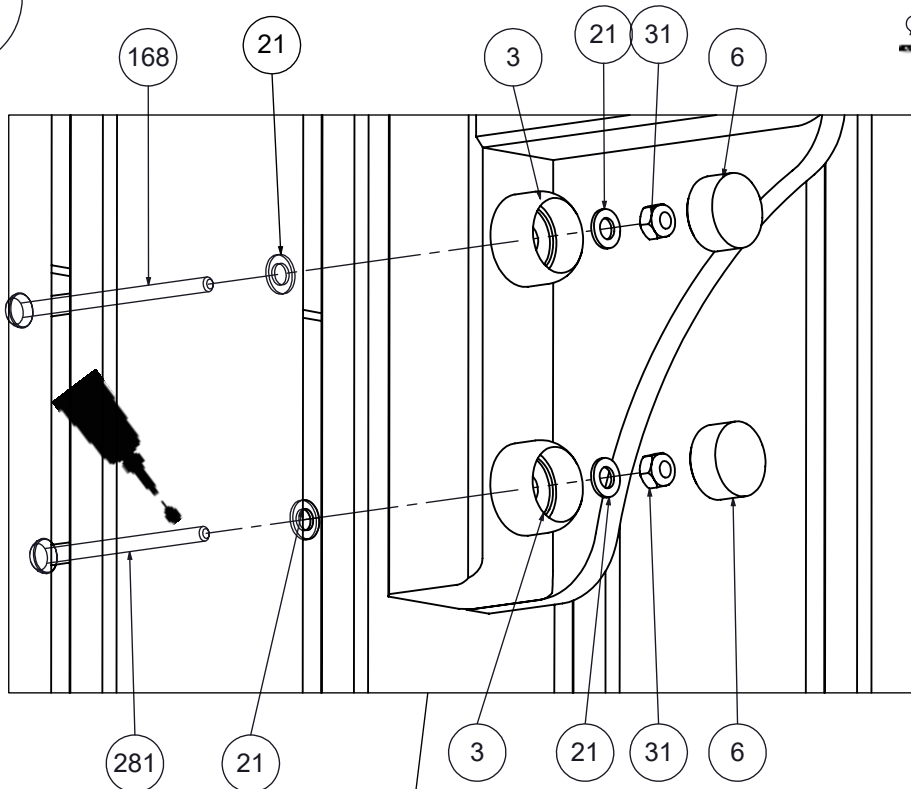

Nr	Σ	Element		
3	4		-	K2_d30_B
6	4		-	Z2_d30_B
10	2		DIN 9021	6x18
11	4		DIN 1587	M6
21	8		DIN 125	8x16
22	4		DIN 125	6x12
31	4		DIN 985	M8 (OC)
58	1		-	LOCTITE
118	2		ISO 7380	M6x50
132	2		DIN 7991	M6x25
168	1		ISO 7380	M8x100
281	3		ISO 7380	M8x95
590	2			K_4_A2_g4_G_v1

3

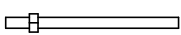
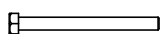

INST_84_34A

1

Nr	Σ	Element		
3	2		-	K2_d30_B
6	2		-	Z2_d30_B
61	2		-	KL105 (OC)
62	1		DIN 931	M12x130
63	2		DIN 125	12x24
74	1		DIN 985	M12 (OC)
323	2		-	8100_59_g8_G_v1

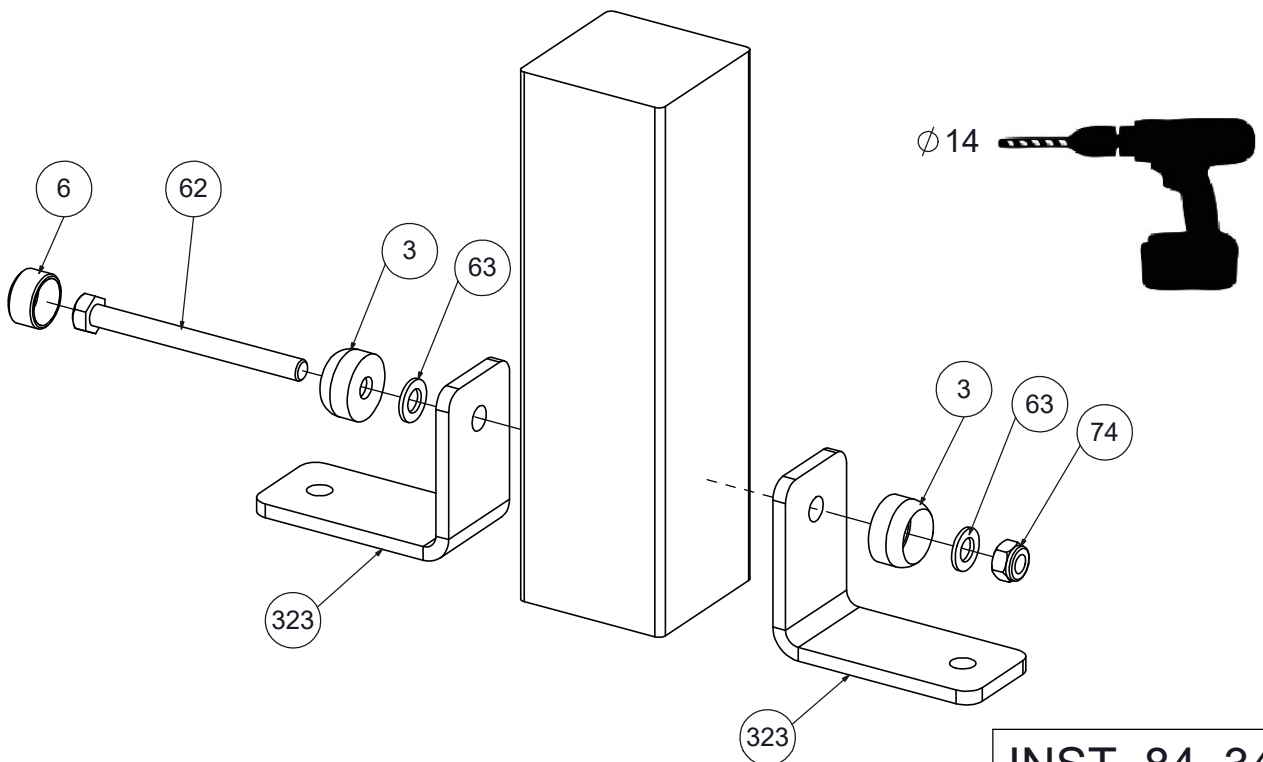
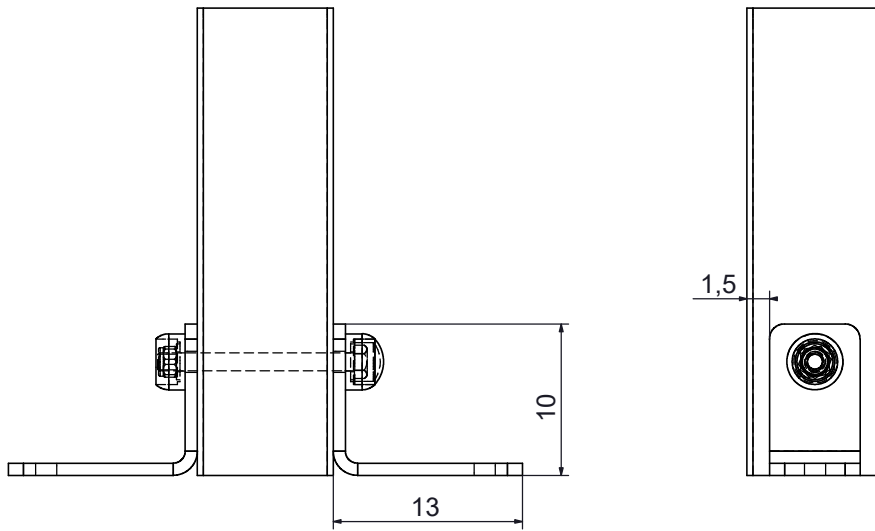

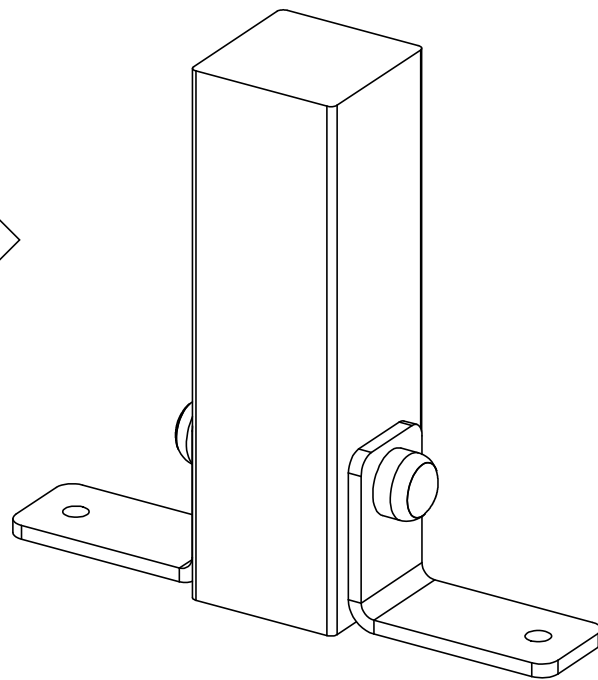
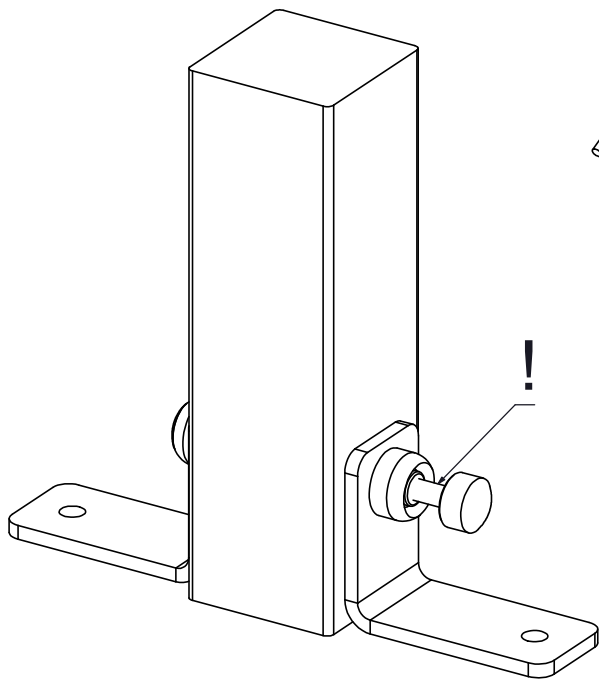
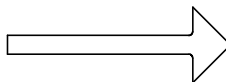
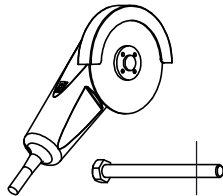
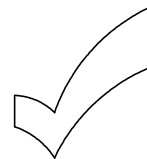
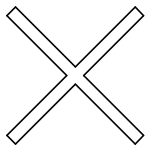
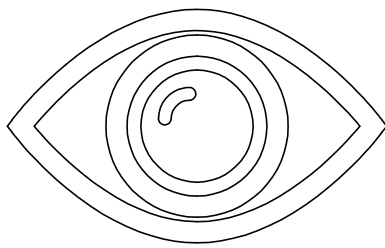



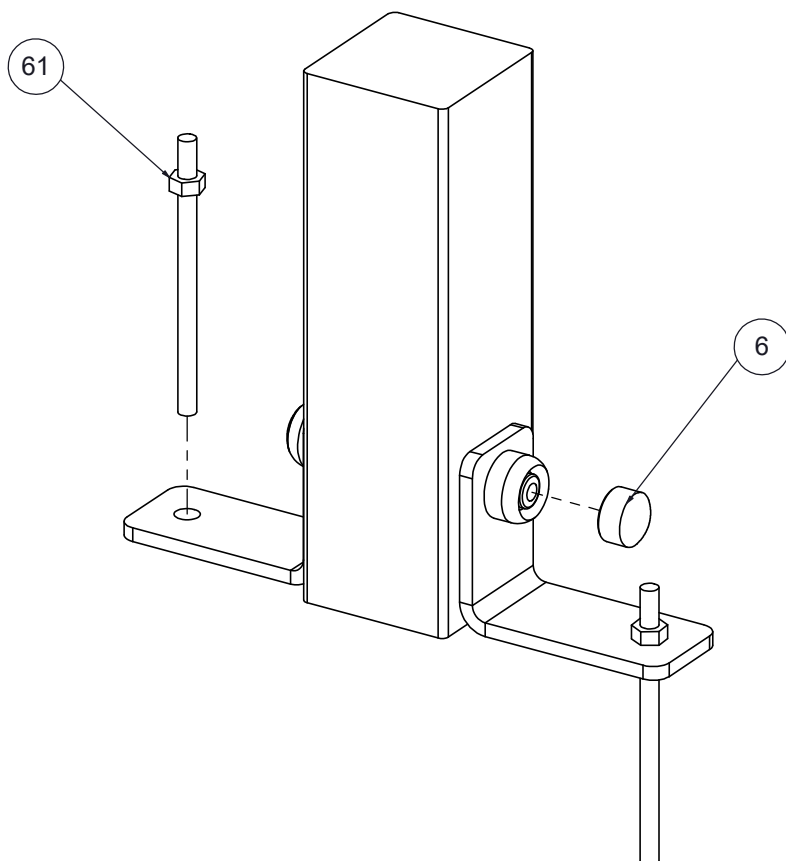



2

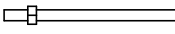

INST_84_34B

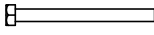
1

Nr	Σ	Element		
3	4		-	K2_d30_B
6	4		-	Z2_d30_B
61	2		-	KL105 (OC)
63	4		DIN 125	12x24
74	2		DIN 985	M12 (OC)
83	2		DIN 931	M12x120
323	2		-	8100_59_g8_G_v1

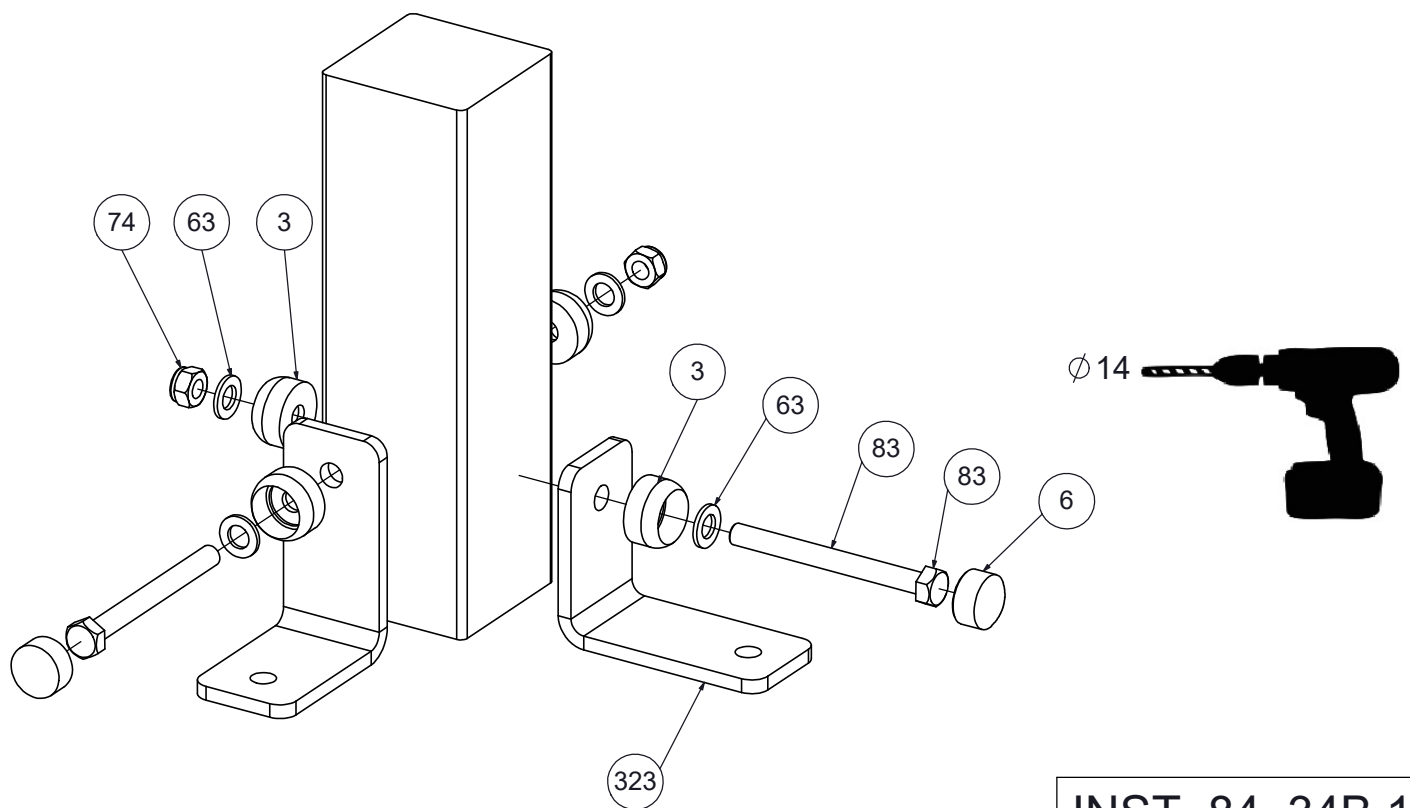
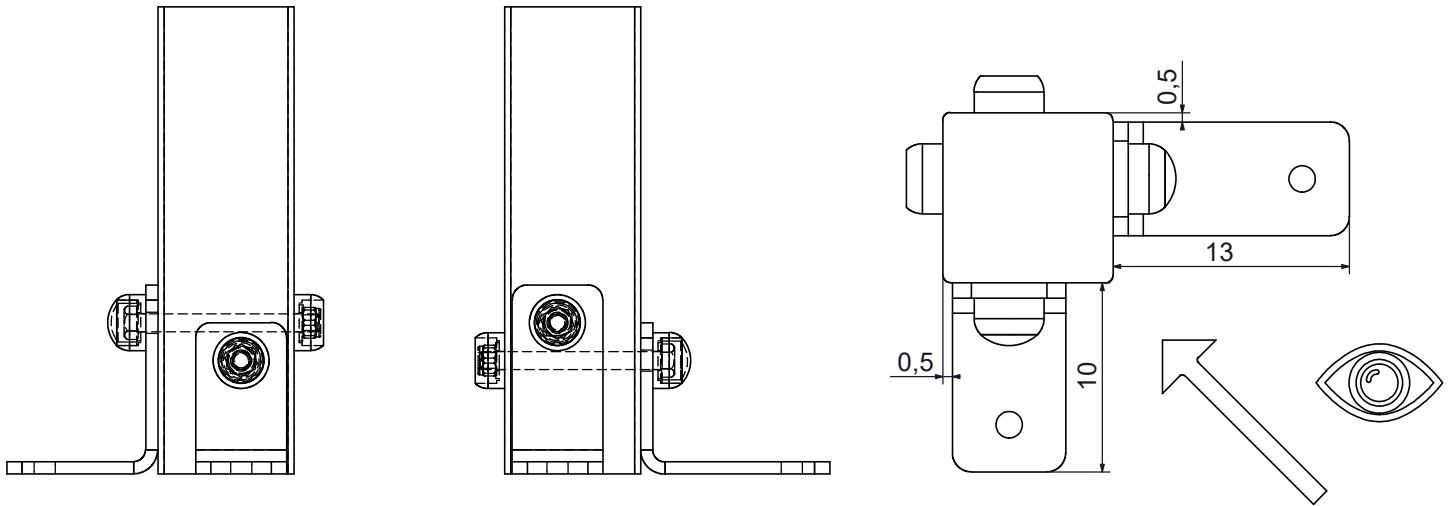

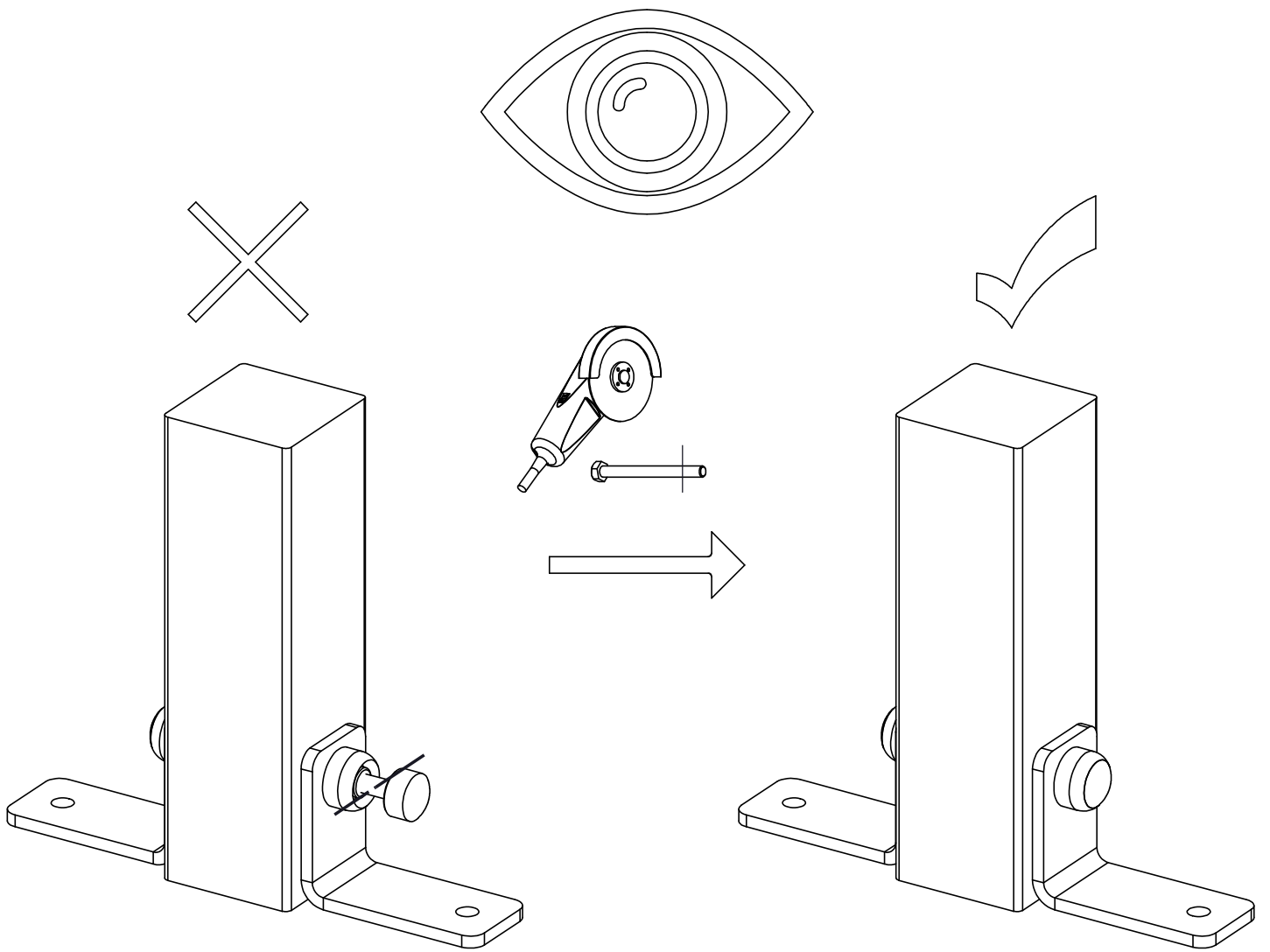



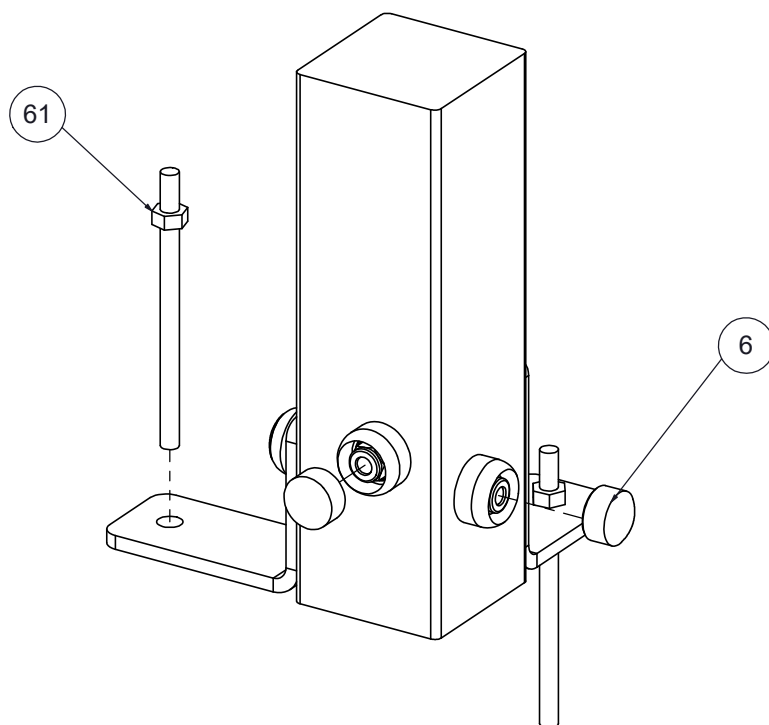

2

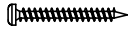

INST_Z_3

Nr	Σ	Element		
1	1		-	S6x60
3	1		-	K2_d30_B
21	1		DIN 125	8x16
213	1		-	Z_NA_1
214	1		-	Z_NA_2

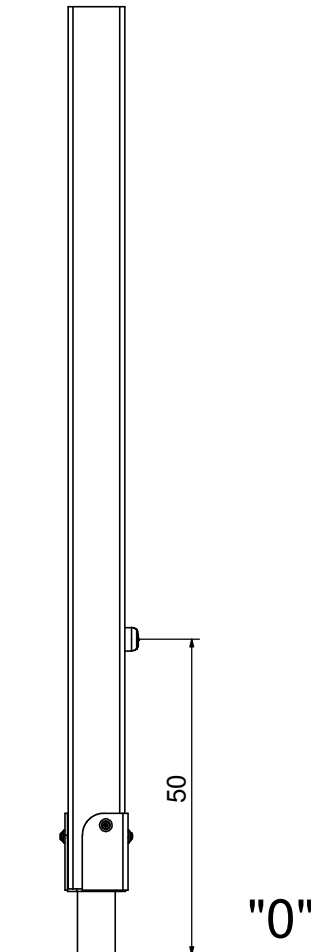
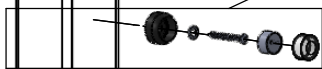
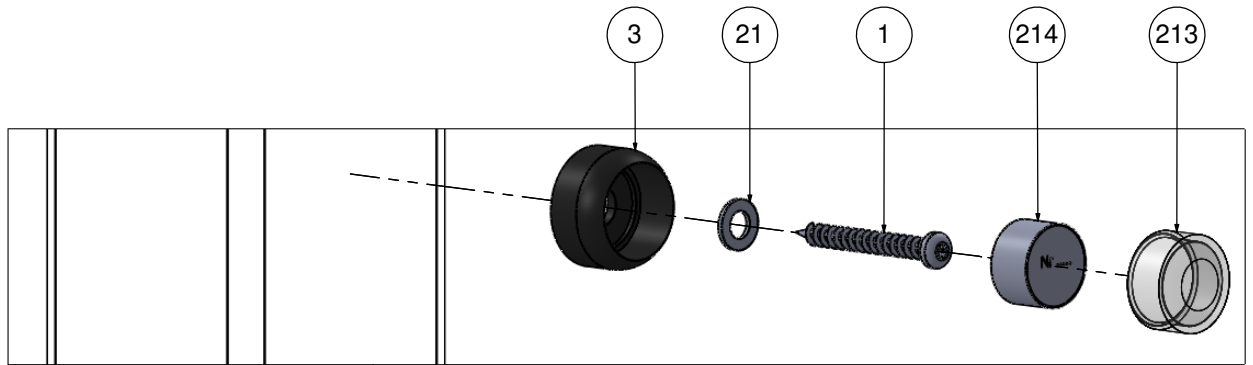
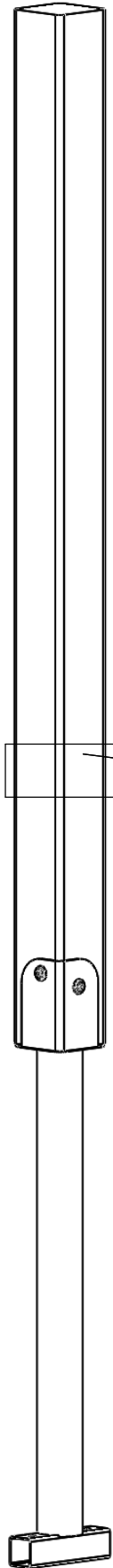

Technical specifications of the 8400 series products

All substitutionary parts for BUGLO's products are available at producer's during whole use period (working life) of the product.

Necessary toolset for the assembly of the products:

- Box wrenches nr 13, 17, 19
- Hex wrenches set
- Electrical screwdriver (extra ends: TX20, TX25)
- Drill - diameter 3mm, 4mm, 6mm, 8mm
- Mallet rubber (rubber hammer)
- Tools used to making holes in the ground/surface
- Level
- Angle grinder

During the assembly pay attention to: tightening all screws, securing and marking mounting location. Before putting device into use it's required to check the stability of all elements, remove protecting tapes and check level and the condition of the amortization surface.

Product installation, conservation and replacement of elements pose a threat for playing children, which is why it is required to mark and secure the assembly space. Such security must guarantee no access to the work space both during and after work. Main threats can be caused by electrical devices and tools, deep foundation holes and incomplete product sets.

During the installation it's required to ensure the assembly space to be about the same size as the safety zone of the equipment.

Inspection and maintenance of the Product

According to the PN EN 1176-1 : 2017-12-Norm

The maintenance and exploitation:

It is required to consult with the Manufacturer about all maintaining works of the Products' parts which are under guarantee.

The anticorrosive surface:

Damaged paint coat should be first cleaned out of dust, fat and corrosion centres. After that, the cleaned surface should be covered with an anticorrosive primer for steel surfaces. When the layer is dry, paint twice with spray paint.

The colour combination used by BUGLO according to the RAL palette:

- 1) Grey - RAL 7035
- 2) Yellow - RAL 1003
- 3) Blue - RAL 5015
- 4) Red - RAL 3000
- 5) Green - RAL 6018
- 6) Black - RAL 9005
- 7) Purple - RAL 4008
- 8) Anthracite - RAL 7016
- 9) Silver - RAL 9006
- 10) Beige – RAL 1019
- 11) Orange – RAL 2009

Robinia wood:

Due to the fact that wood is a natural material, cracks in a radial way may appear, do not affect the stability of the construction. Cracks that split the wood into two may be dangerous. Pay attention to the location of the crack and if is dangerous - the element should be replaced. Gaps need to be controlled and when necessary, sharp edges shall be grinded.

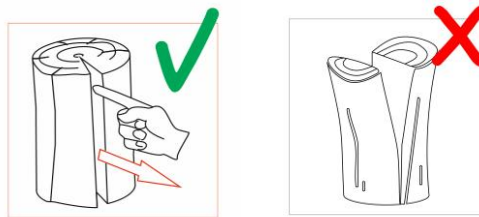

At least 4 times a year, bolted connections of Robinia wood construction elements shall be checked. If necessary, retighten the connections according to the following scheme:

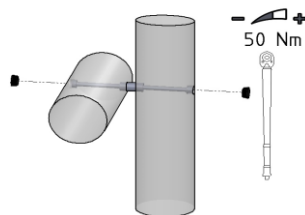

Tension of the nets and rope elements assembled to wooden posts should be done by cutting the chain at rope ends.

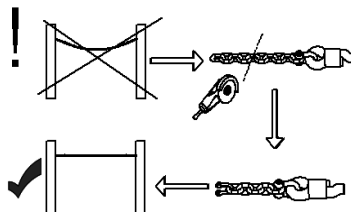

Caution! Robinia wood, due to natural preservative content, impregnation is not recommended. All materials give in to the natural ageing of products. During the time pass their esthetical properties can get worse. It's a process, which not influence the durability of the product and its' safety. Acceptable are changes in the intensity of the colour and cracks of wood.

Paint coating on elements made of robinia is used only to achieve a visual effect. It is recommended to renew damaged paint coating to restore the aesthetic appearance of the device. Renovating surface should be cleaned, matted, dusted off and then painted. To get proper paints, ask the Product Manufacturer.

Stainless steel:

It is recommended to clean stainless steel elements once a year, to remove sediments and contaminants, which accumulation can cause steel discolouring. Wash with cotton cloths and gentle detergent dissolved in water, eg. dishwashing liquid. After cleaning rinse with water and wipe dry.

Caution!

Cleaners used to clean stainless steel **must not** contain: chlorine, salt, acids or bleaches. Even small amount of these substances can cause permanent damage of chromium oxide surface.

Recommendations for the product inspection according to the EN 1176-7: 2009-Norm Playground equipment and the surfaces part 7: Guidelines on installation, inspection, maintenance and operation.

1) The periodic control - if the product is used very intensively or is exposed to vandalism, the control should be carried out once a week or more frequently.

The periodic control includes:

- completeness of the products
- checking if there are no cracks, sharp edges or other damages
- the cleanness around the Product (broken glass determines a big danger) and smoothing the safety surface
- general safety status of the playground.

2) The functional control - should be carried out once every three months.

It includes the range of the periodic inspection enlarged by examining the Products' functions.

- during the functional control the fixed elements of the Product should be checked (completeness of caps and masking elements)
- checking the stability of the posts
- checking the loose-fill safety surface (eg. sand, gravel, bark, woodchips) and evening it out. If the level is under 10cm below the marked surface level, it must be filled in
- tighten all screws
- checking the tension of the zip line rope and nets.
- checking the wood for cavities and traces of rot, also under the surface and at the foundation.
- checking the condition of paint coatings on wooden elements.

3) The functional control and the main control – mandatory once a year

The main control covers:

- checking the construction stability
- checking and reconstructing the anti-corrosion coating that was damaged
- checking the foundation condition
- checking the loose-fill safety surface (eg. sand, gravel, bark, woodchips) and evening it out. If the level is under 10cm below the marked surface level, it must be filled in.

All the devices should have a regular check-up control. Every time during the check-up an administrator should record everything on a control sheet. Proposed control sheet of the playground in the attachment A1.

Control sheet of the playground

Administrator of the playground

Controlled equipment (product number, manufacturer number)
--

Check-up plan

Check-up run once a week or more often, depends on how intensively the product is used (periodically)		YES	NO
1	General condition of the safety on the playground.		
2	Is the set complete?		
3	Are there any cracks, sharp edges or other damages in the device?		
4	Is the area surrounding the device clean (no glass, safe surface horizontal/even)?		

Check-up run once in a three months (functional)		YES	NO
1	Are the non-separable elements complete (covers and masking elements are complete)?		
2	Are the posts stable?		
3	Is the powdery safe surface horizontal/even?		
4	Is the level of the safety surface up to the marked level or is max. 10cm below this level?		
5	Are the ropes and nets tensioned correctly?		
6	That there are no signs of rotting?		
7	Are there any damaged paint coatings on wooden elements?		

Check-up run once a year (functional and main)		YES	NO
1	Is the construction stable?		
2	Are there any damages to the anticorrosional coat?		
3	Is the powdery safe surface horizontal/even?		
4	Is the level of the safety surface up to the marked level or is max. 10cm below this level?		

Fault/Repair

1	
2	
3	
4	
5	

Parts exchange

	Name of the part	Qty	Reason
1			
2			
3			

	Date	Inspector's name
1		
2		
3		
4		