

9503

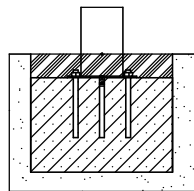
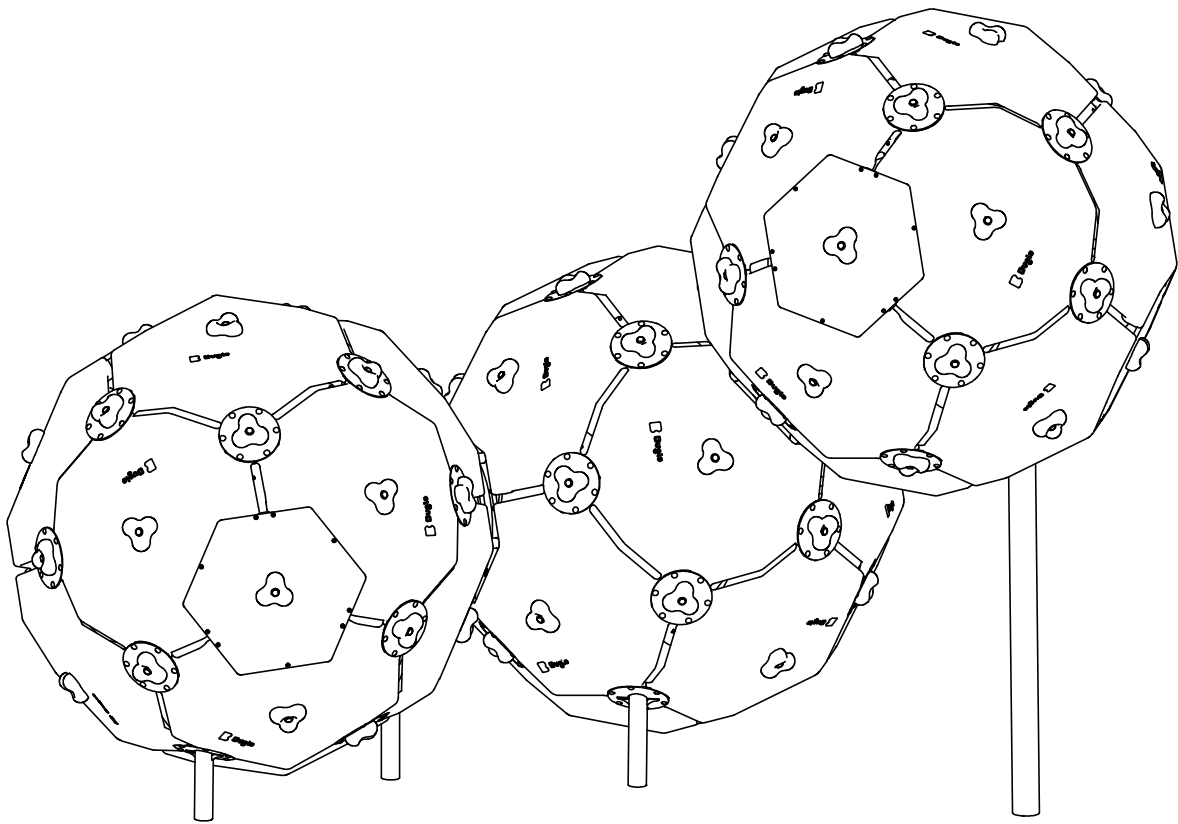

9503N

NR

ELEMENT

9503N

E1

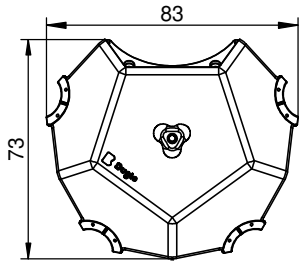

COLOR "A"

18

E2

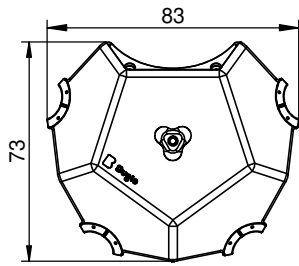

COLOR "B"

18

E3

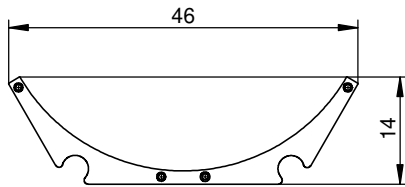

12

E4

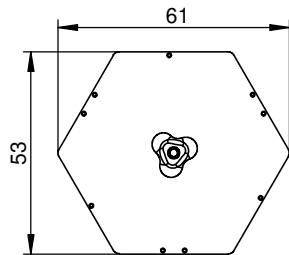

8

E5

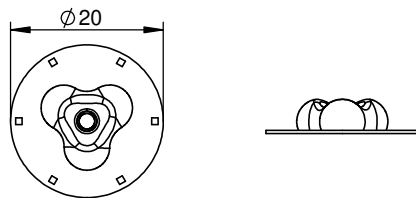

42

E6

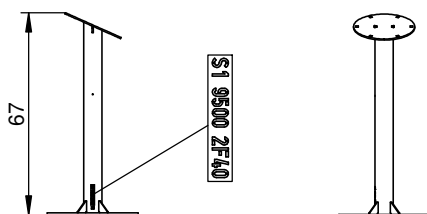

S1_9500_2F40

1

NR

ELEMENT

9503N

E7

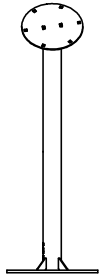
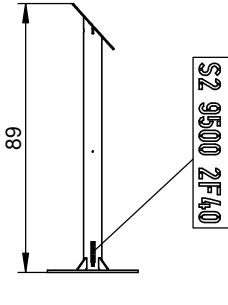

1

E8

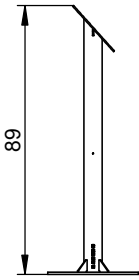

S3_9500_2F40

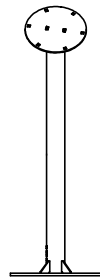

1

E9

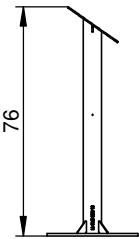

S4_9500_2F40

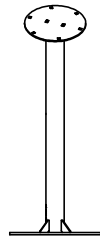

1

E10

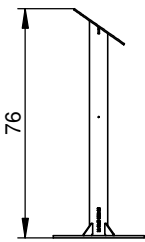

S5_9500_2F40

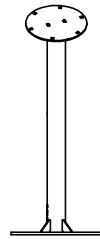

1

E11

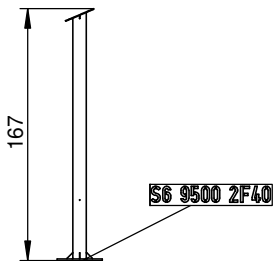

S6_9500_2F40



1

E12

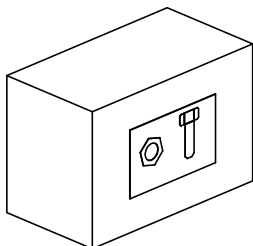

1

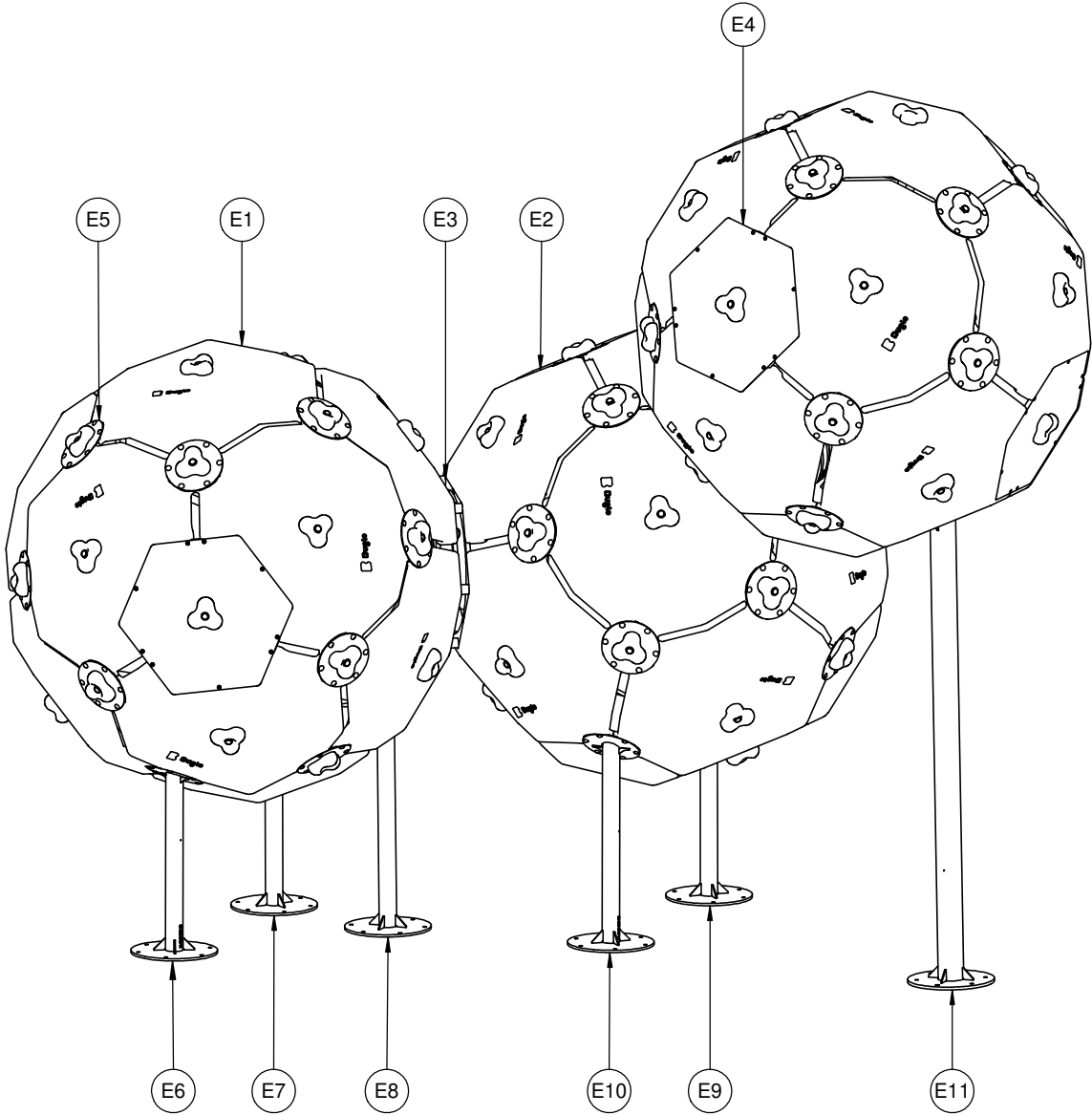

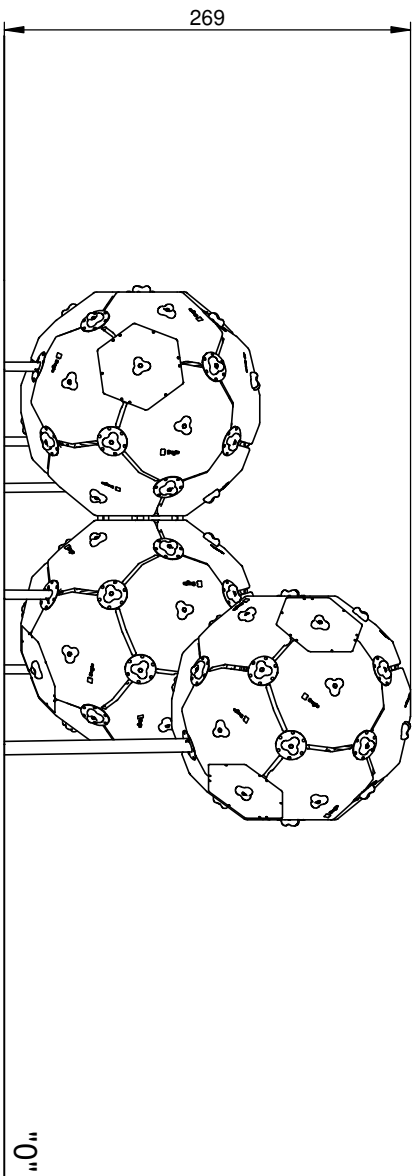
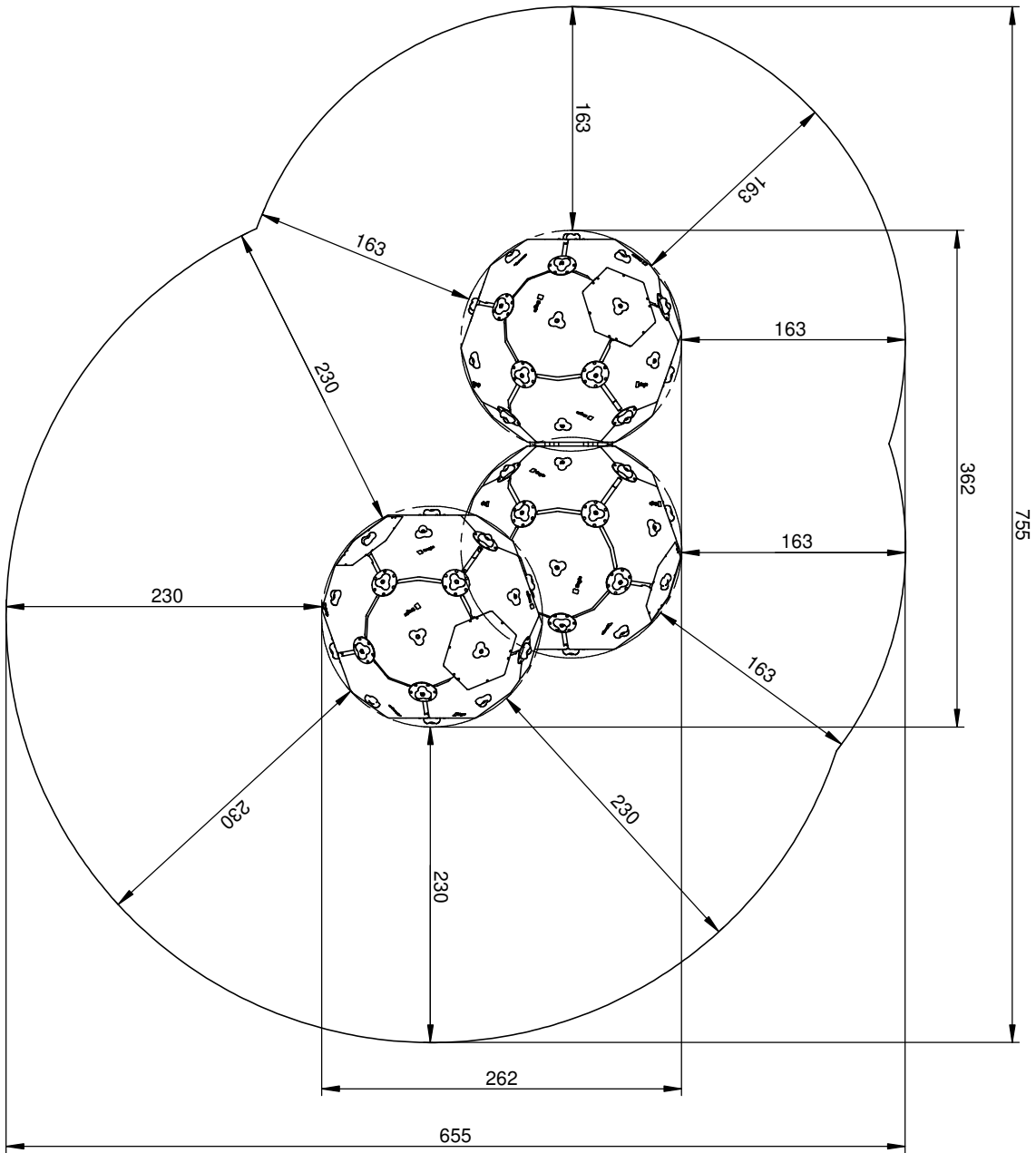

9503N

9503N

3

B25 0,81m

min. 48H

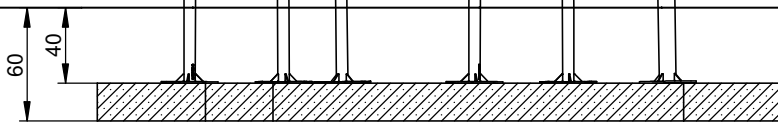
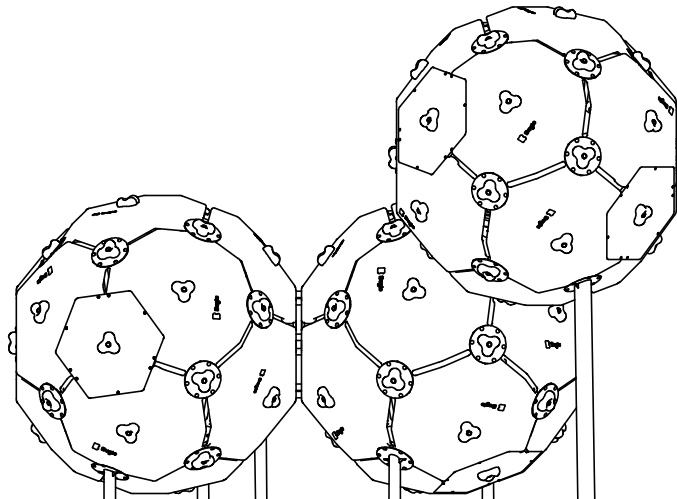
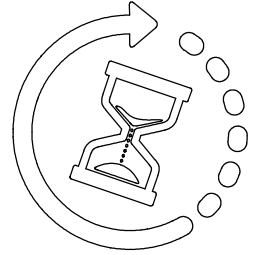
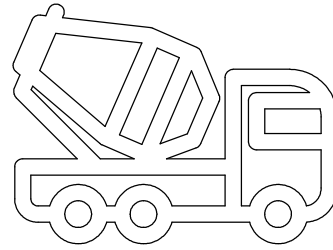
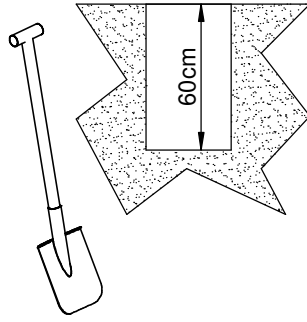

"0"

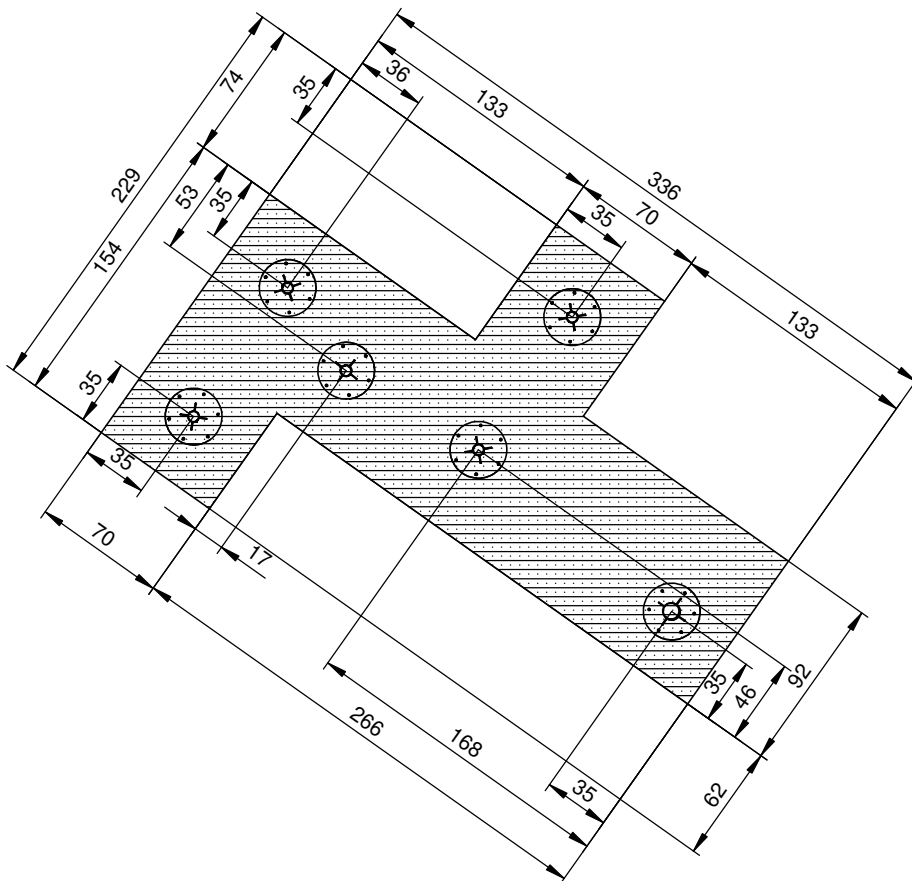

1

9503N
9503F

INST_95_1
INST_95_2
INST_95_6
INST_Z_1

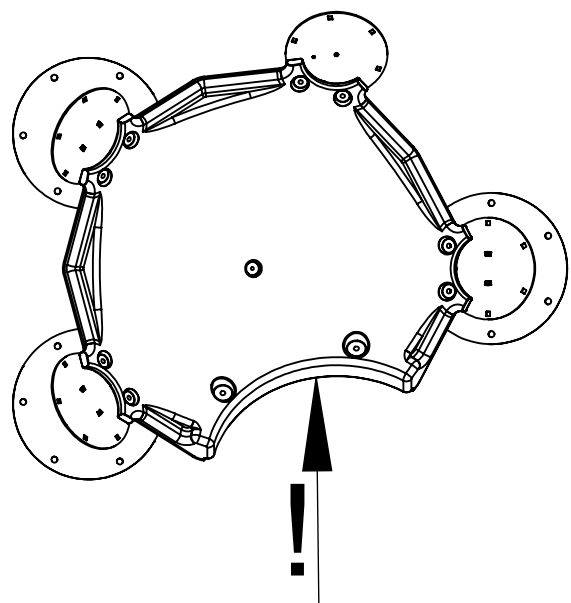
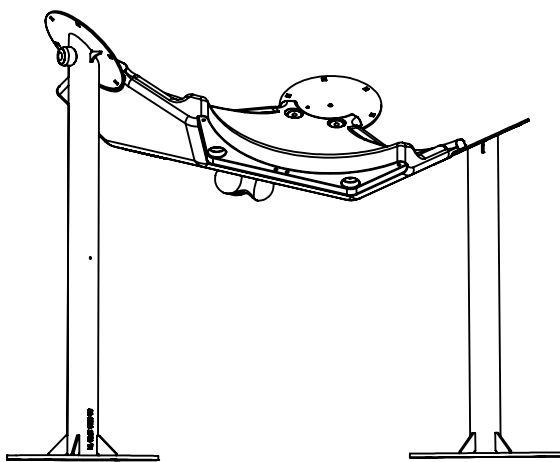
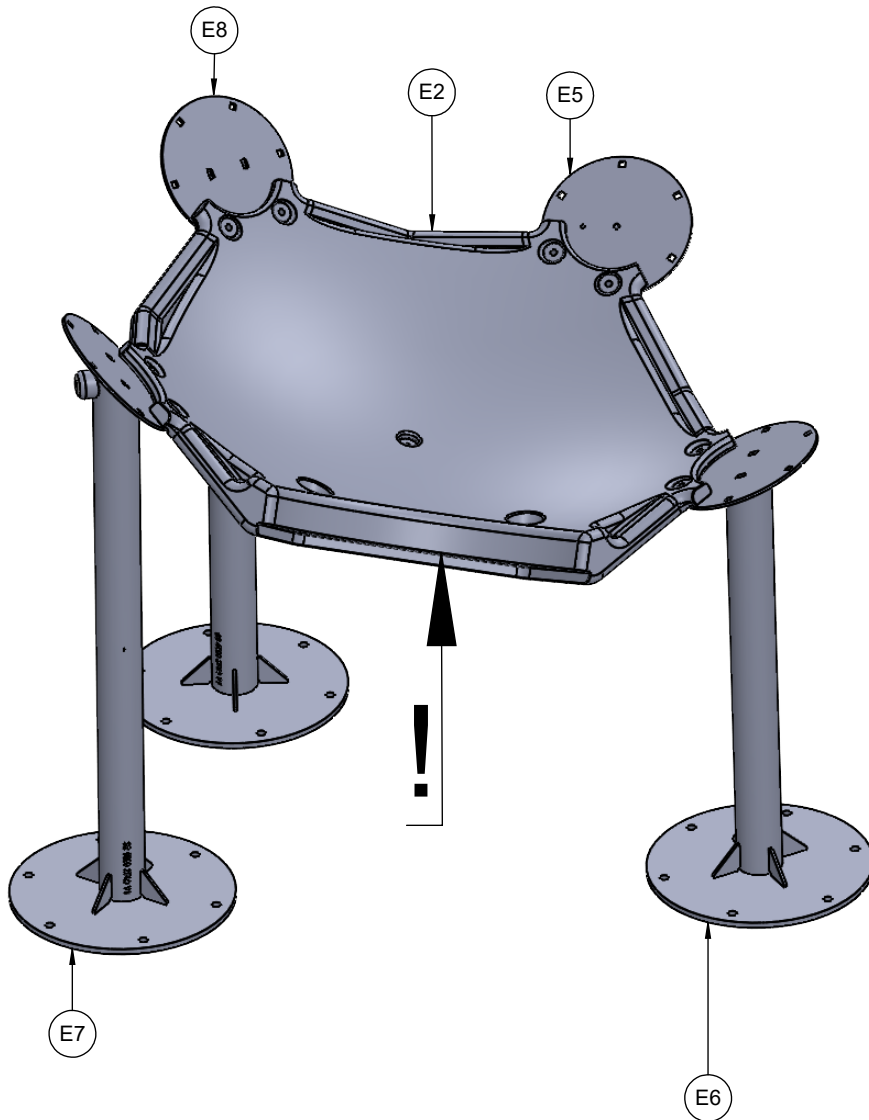

2

9503N
9503F

INST_95_2
INST_95_6

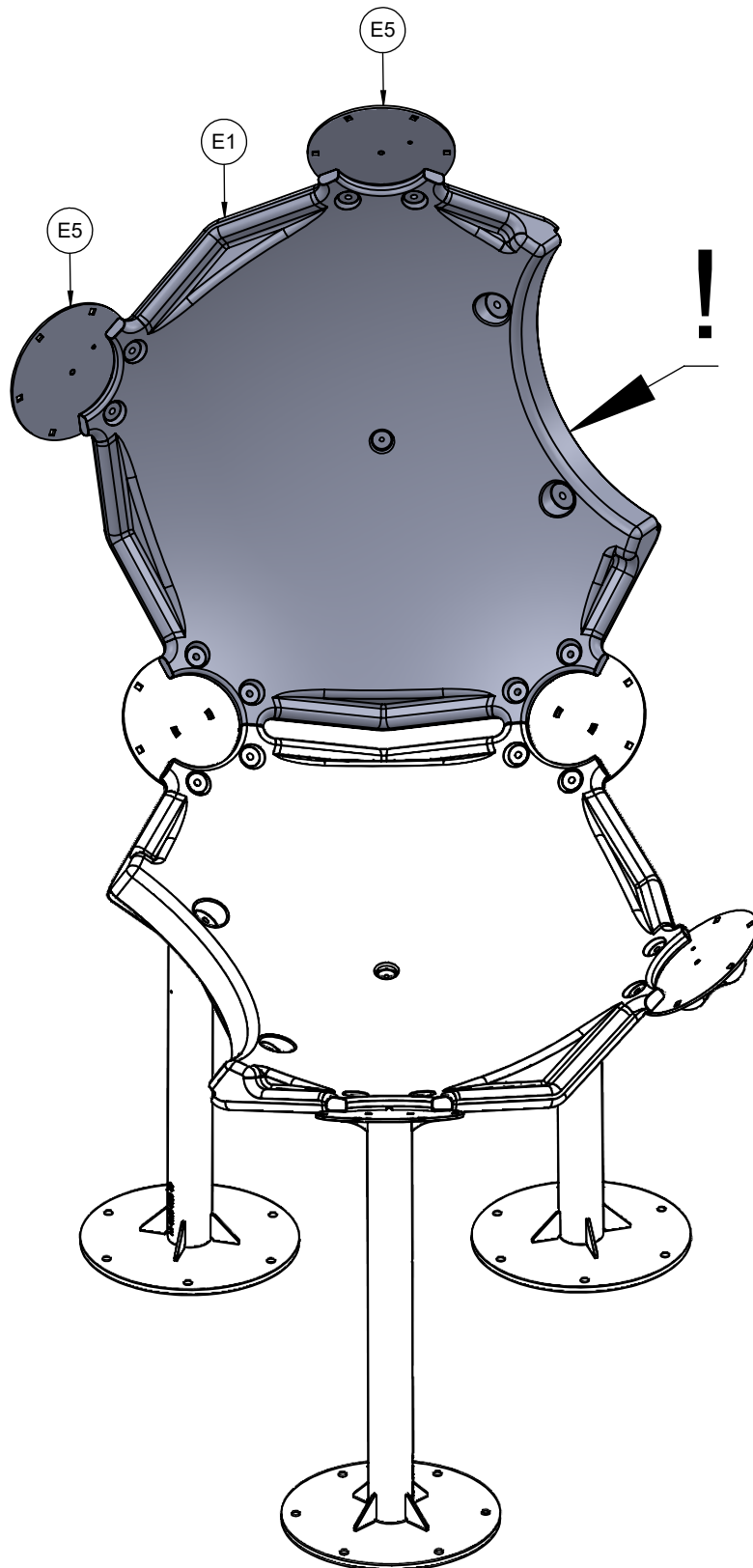

3

9503N
9503F

INST_95_2
INST_95_4A_1
INST_95_6

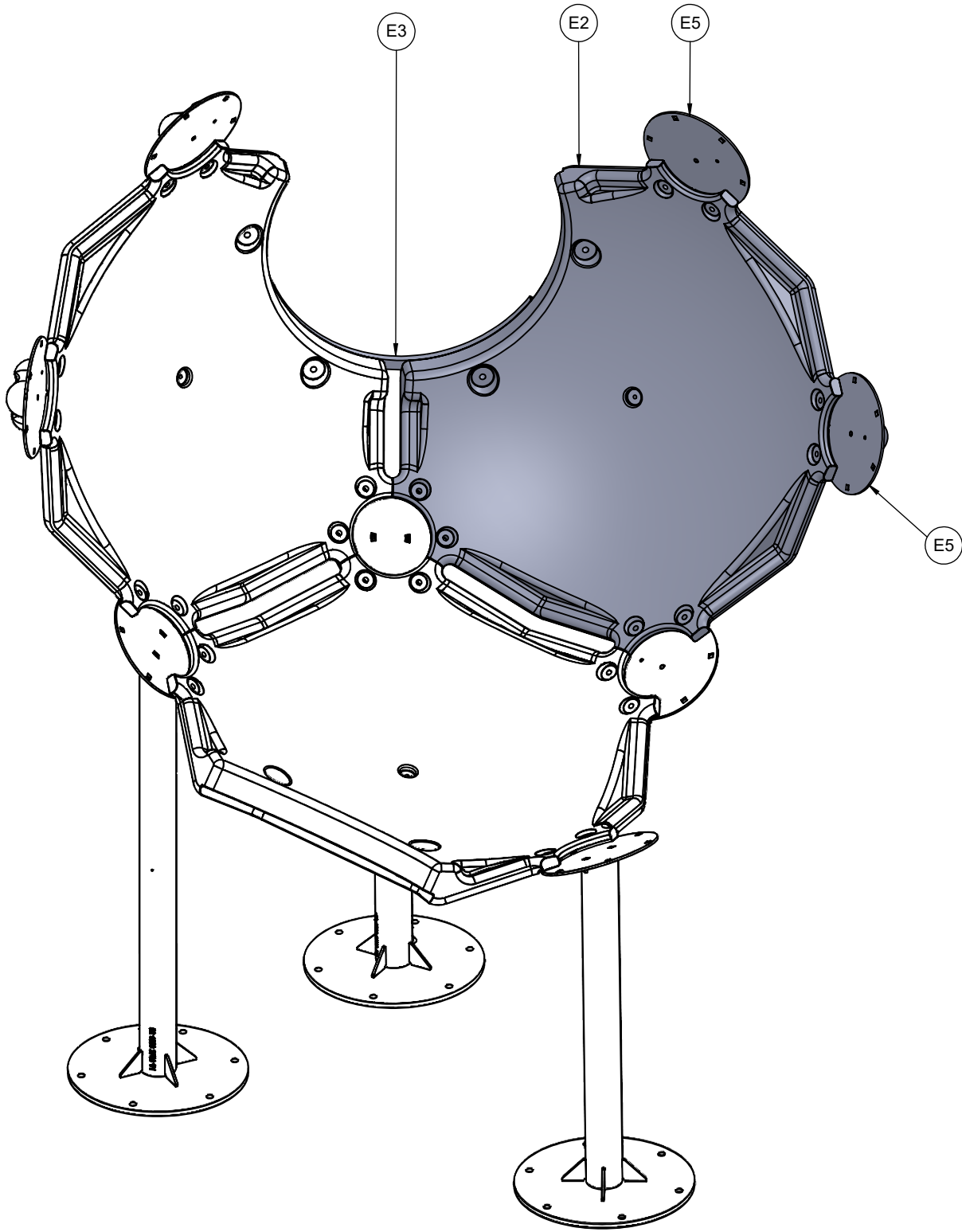

4

9503N
9503F

INST_95_1
INST_95_2
INST_95_4B
INST_95_6

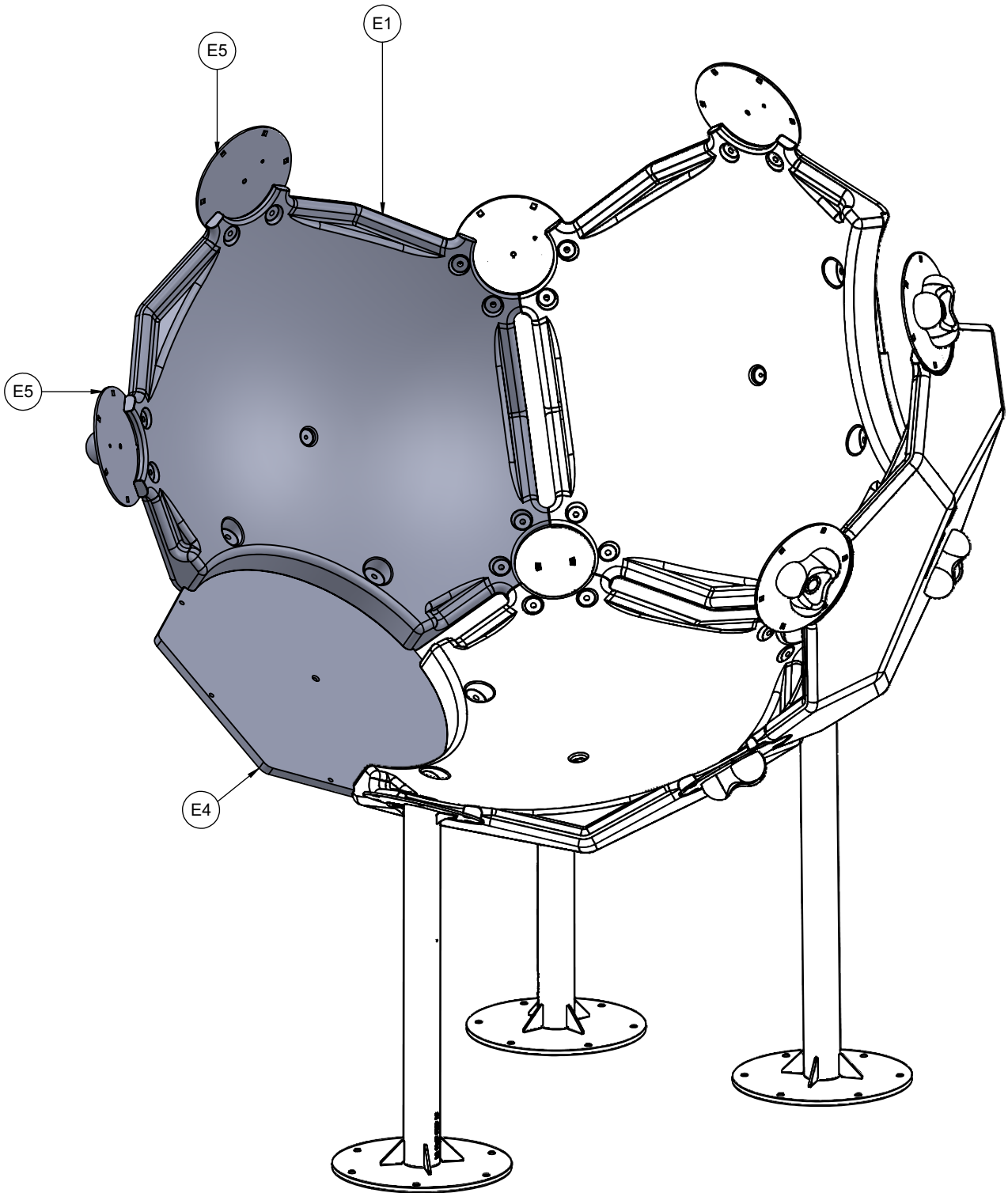

5

9503N
9503F

INST_95_1
INST_95_2
INST_95_4B
INST_95_6

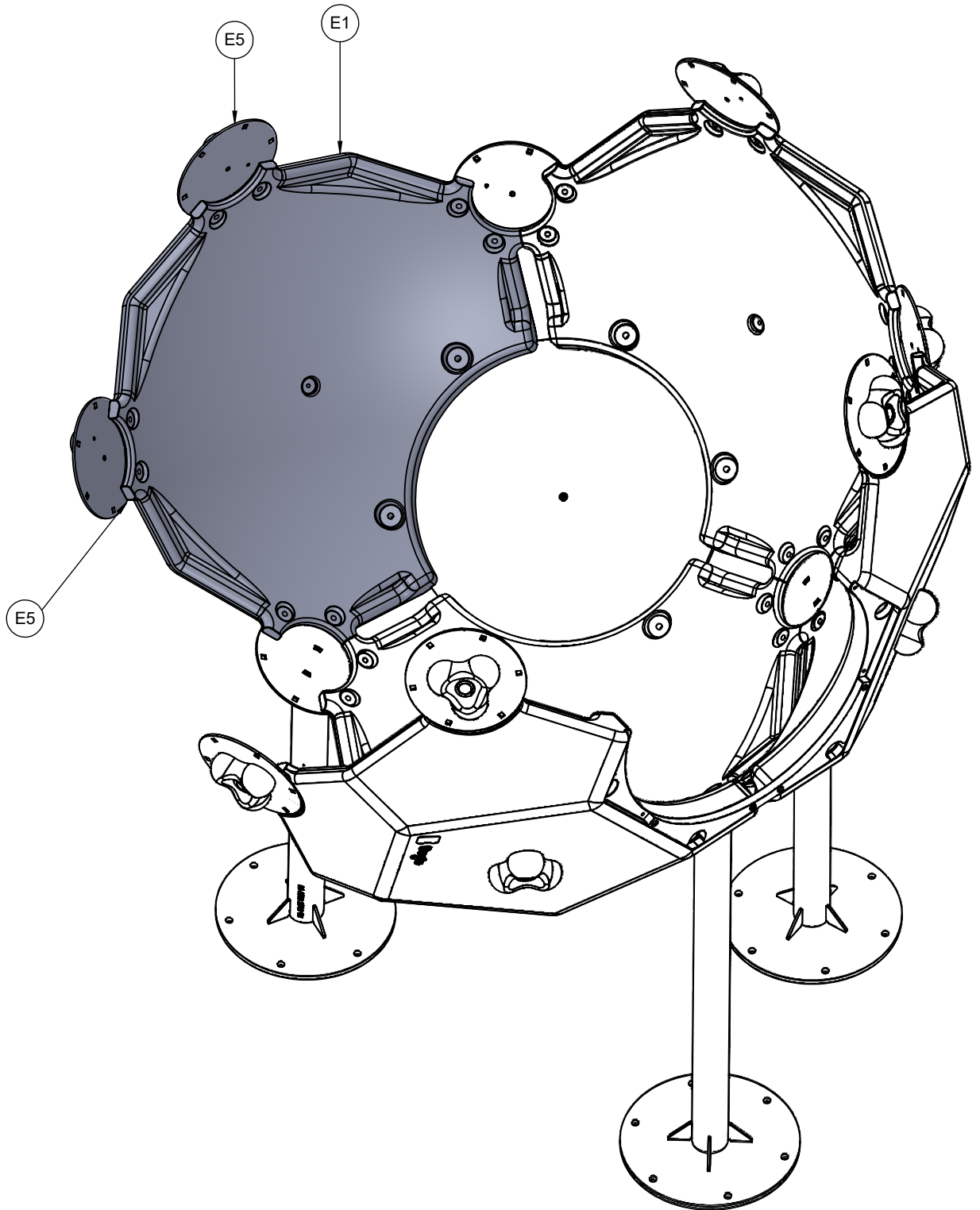

6

9503N
9503F

INST_95_1
INST_95_2
INST_95_6

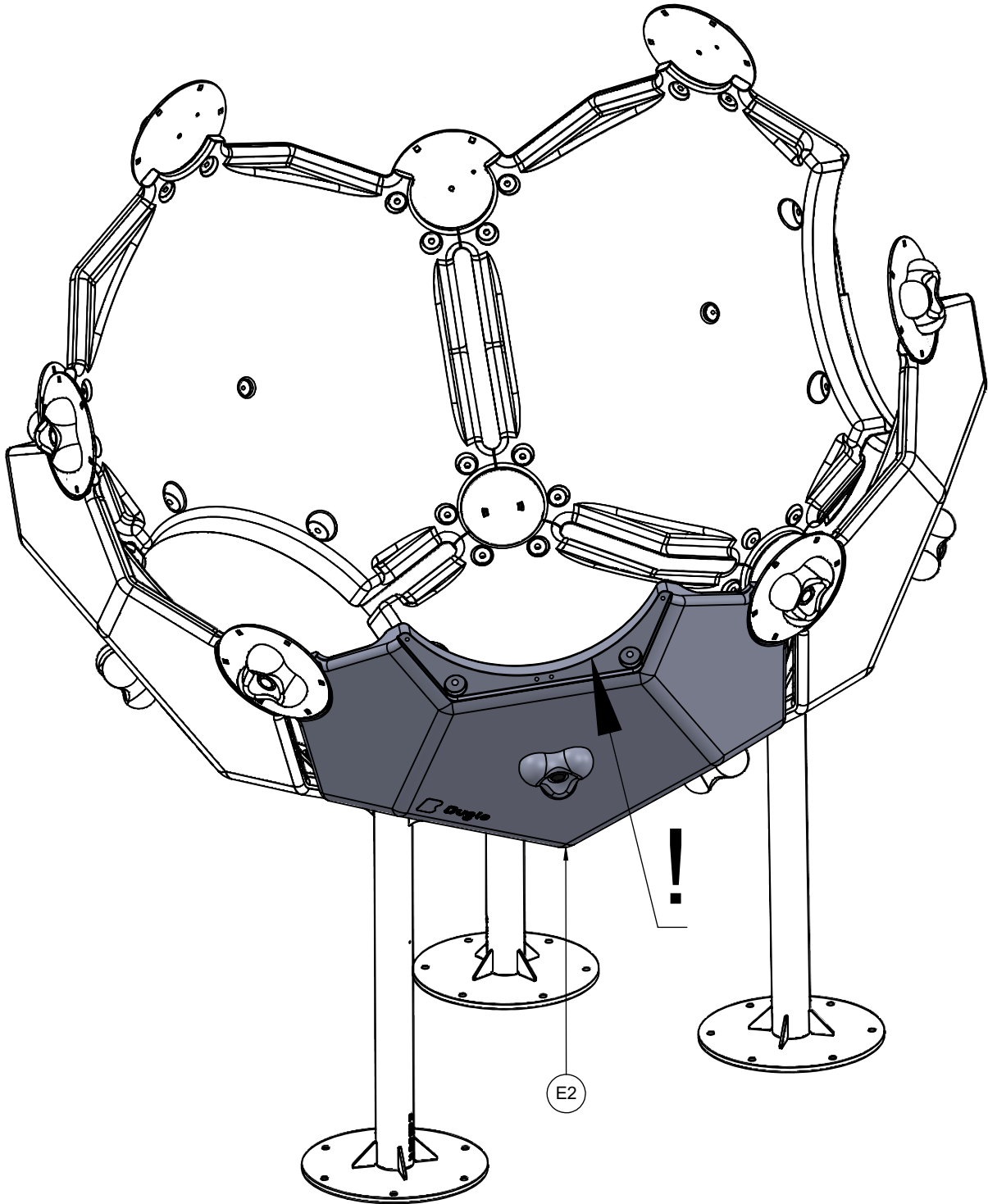

7

9503N
9503F

INST_95_4A_1
INST_95_6

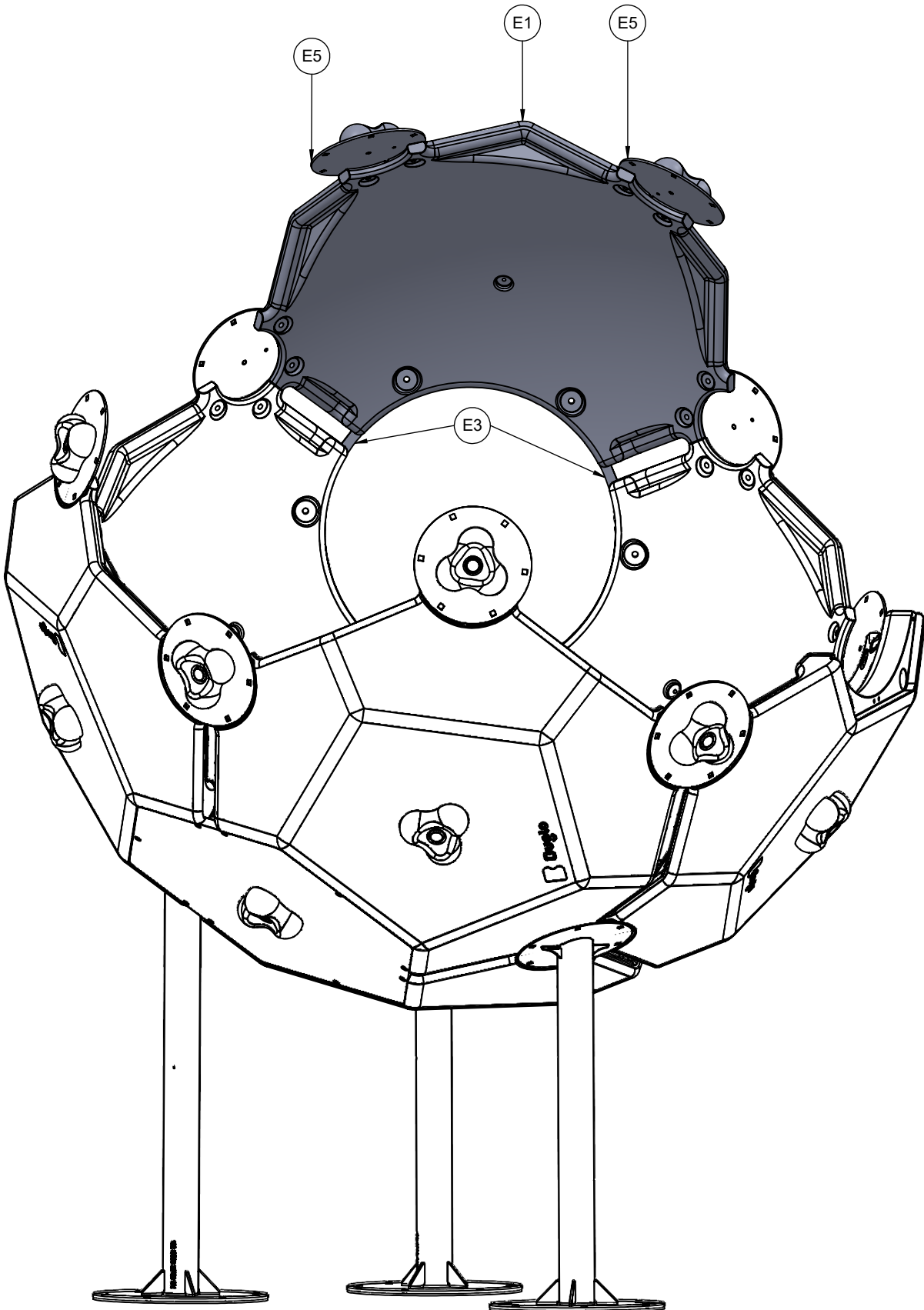

8

9503N
9503F

INST_95_1
INST_95_6

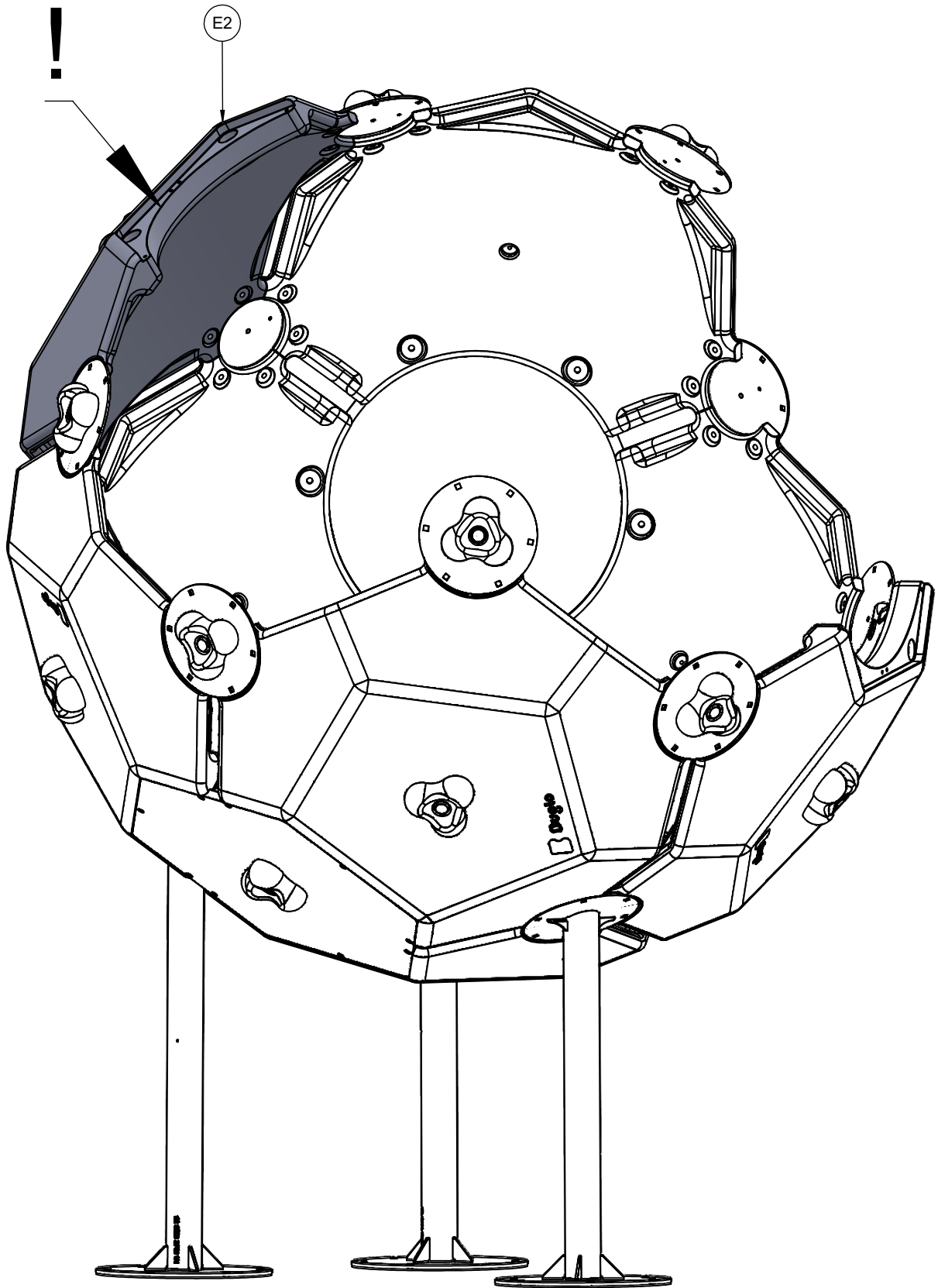

9

9503N
9503F

INST_95_1
INST_95_4B
INST_95_6

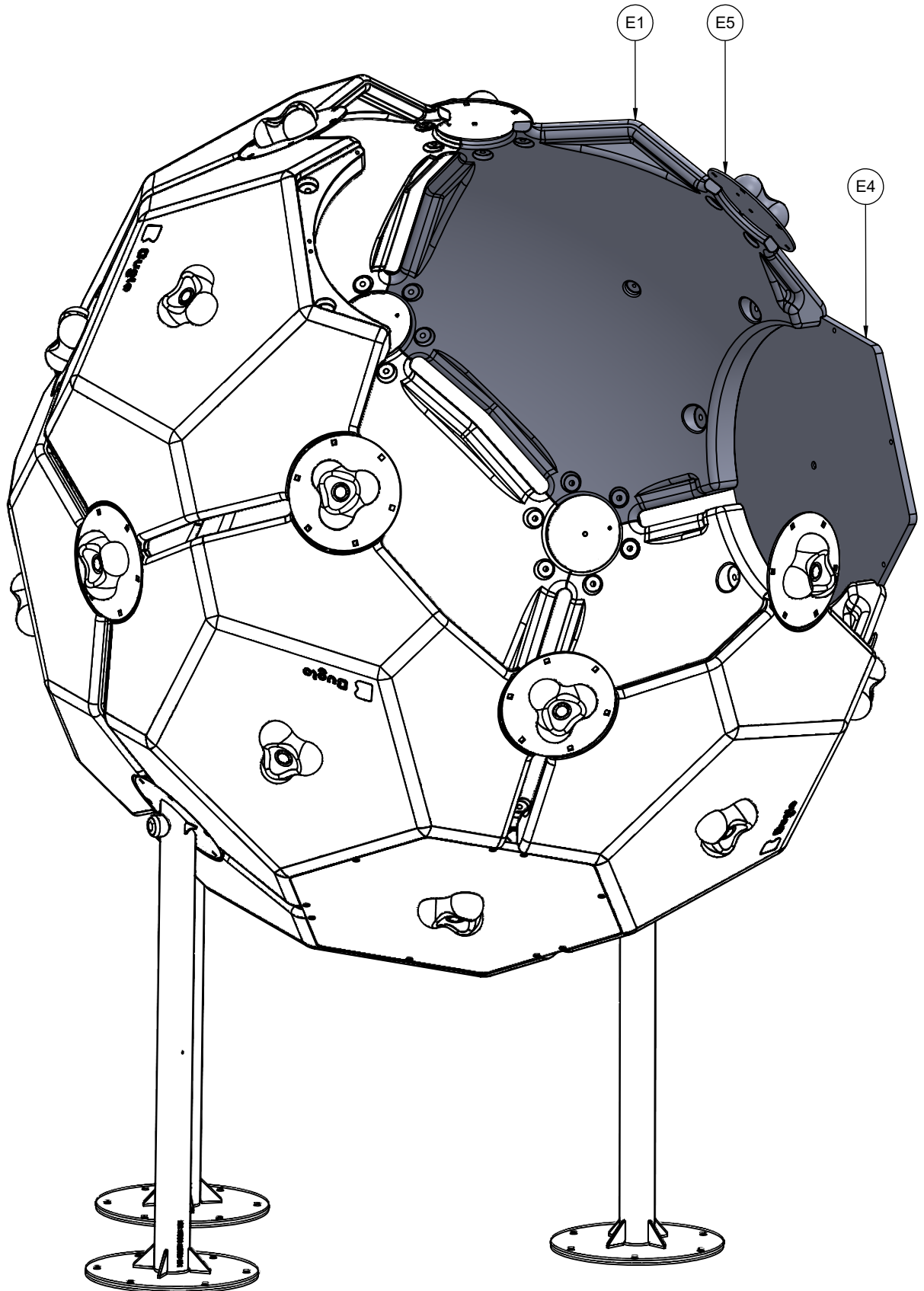

10

9503N
9503F

INST_95_1
INST_95_4B
INST_95_6

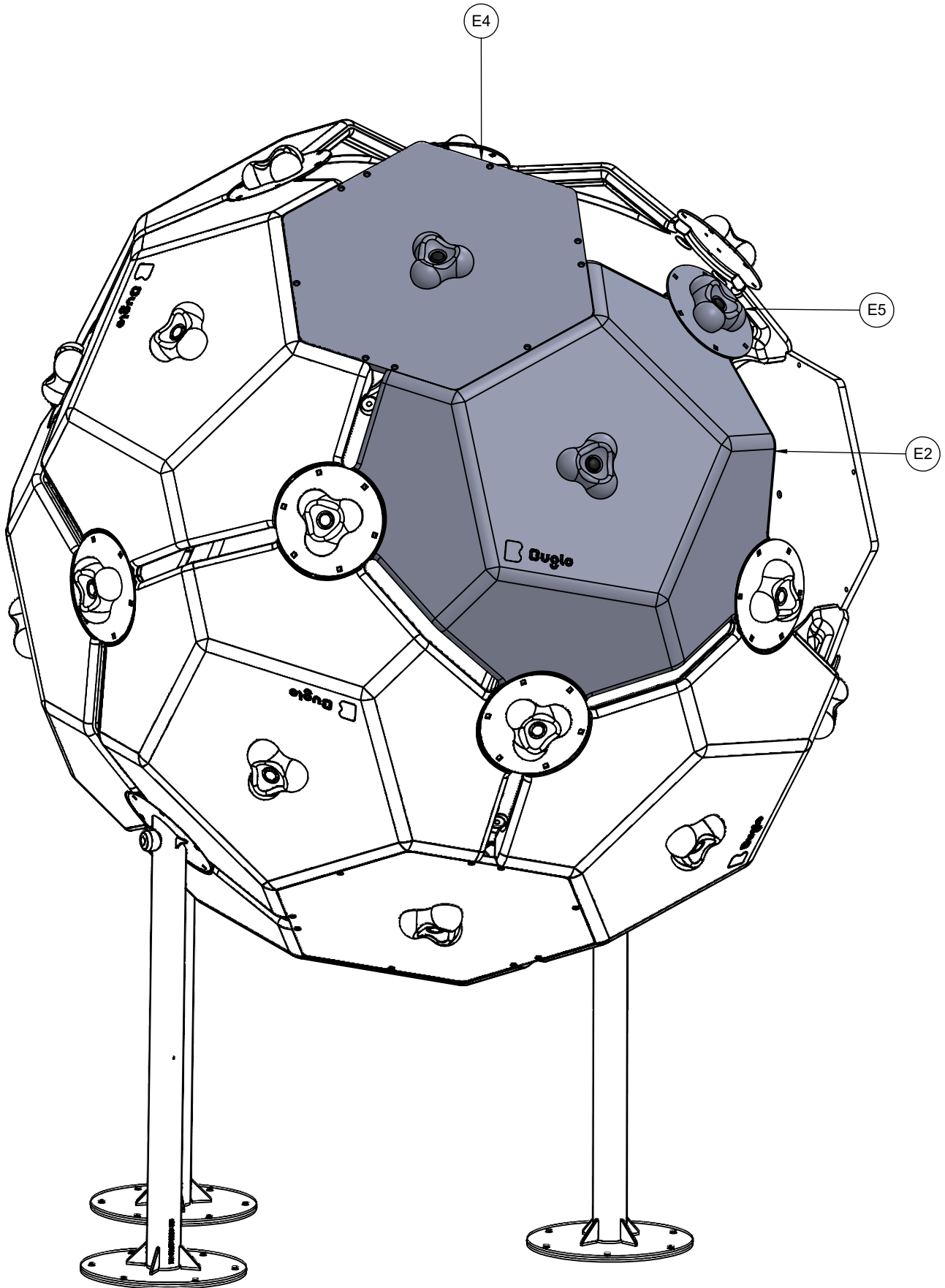

11

9503N
9503F

INST_95_1
INST_95_4B
INST_95_6

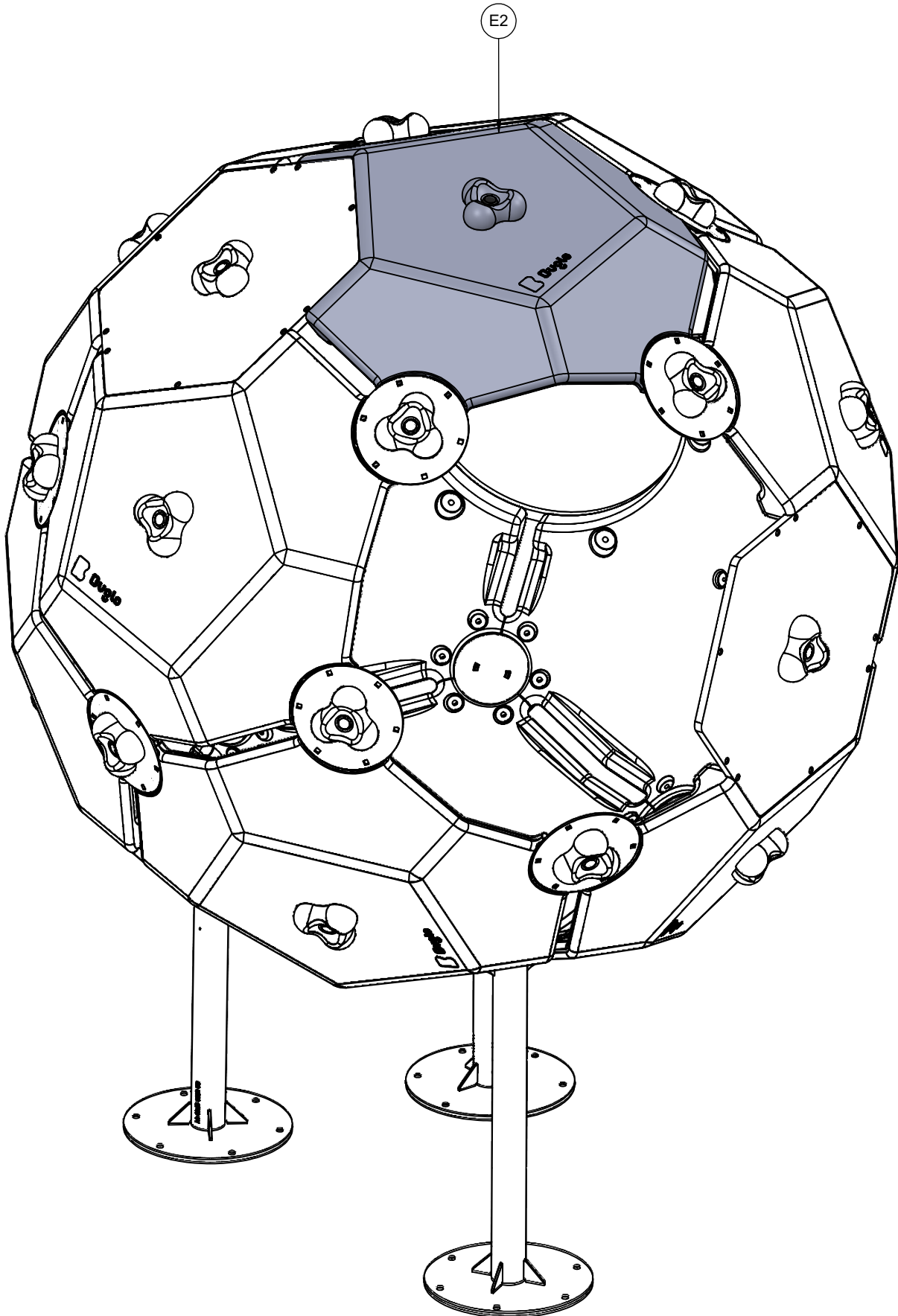

12

9503N
9503F

INST_95_1
INST_95_4B
INST_95_6

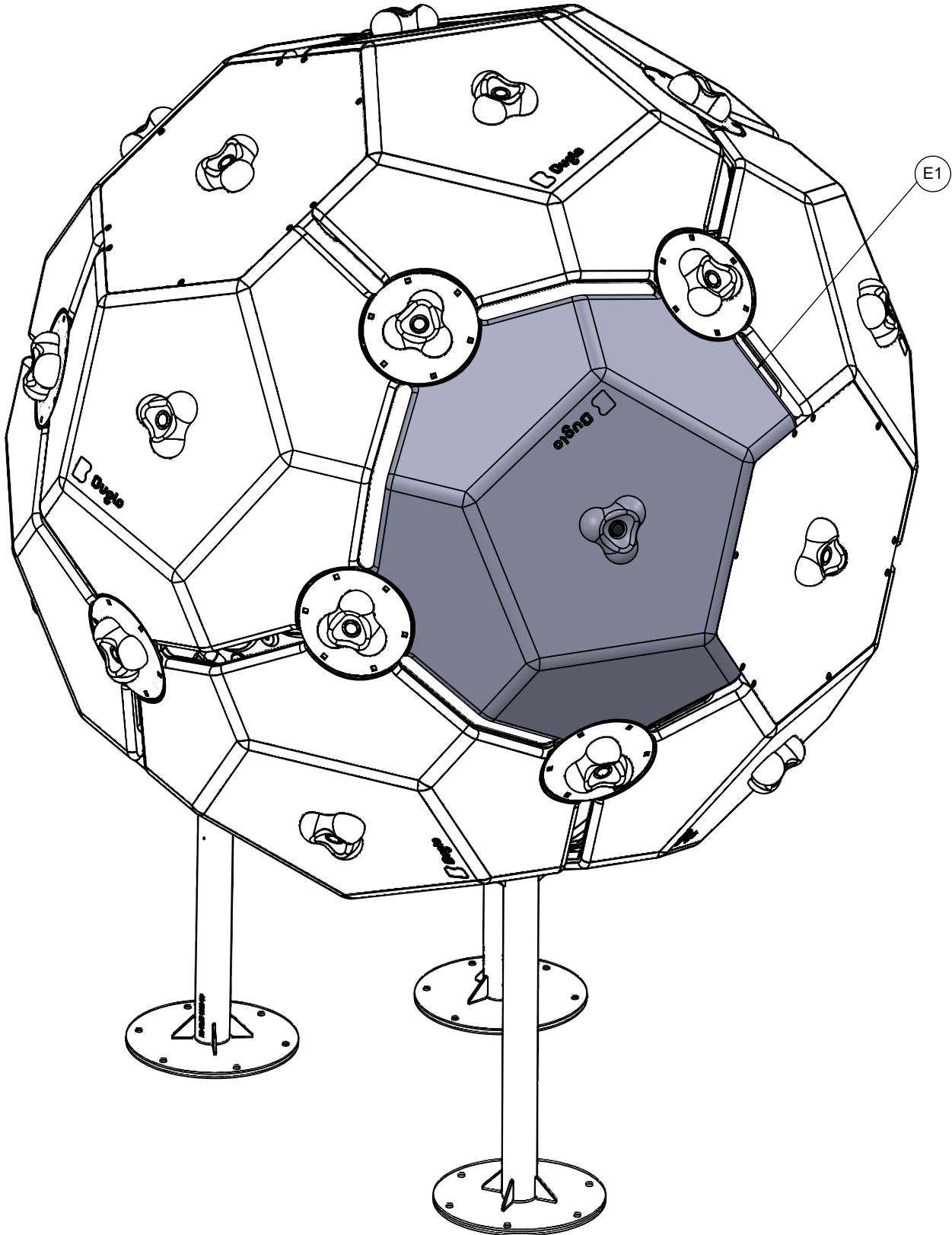

13

9503N
9503F

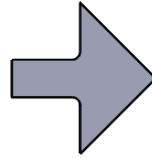
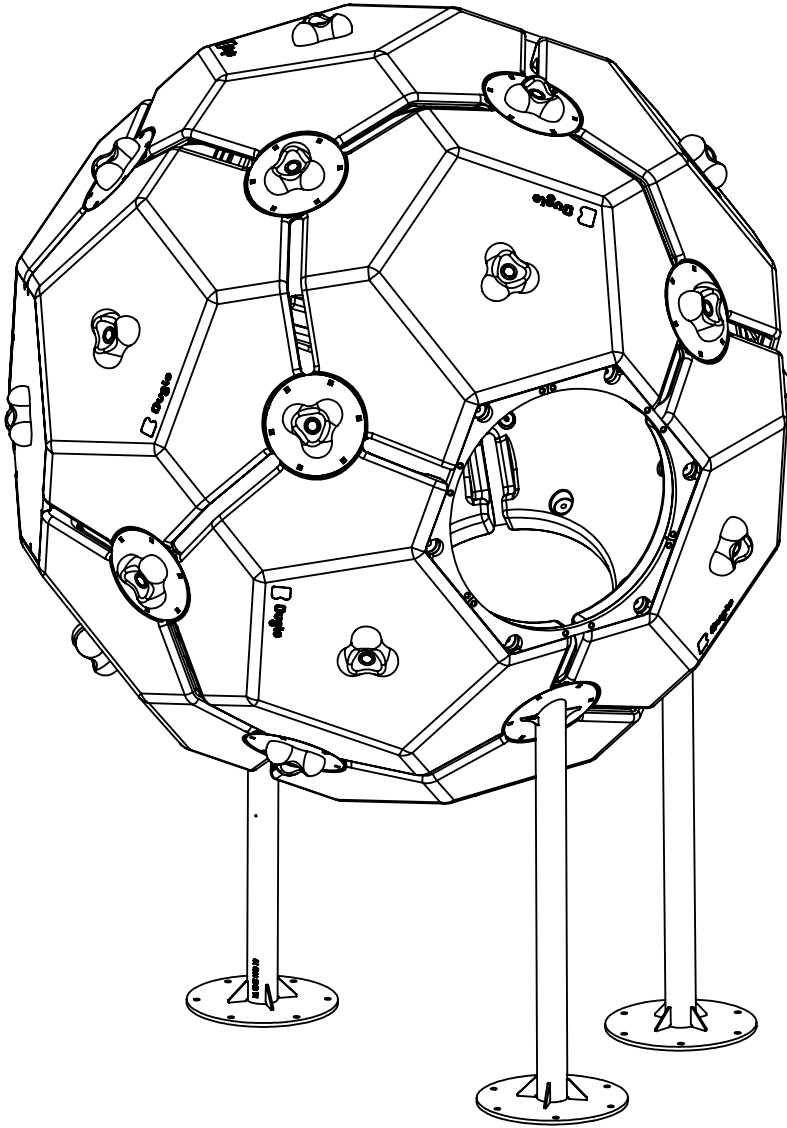

INST_95_2

2

INST_95_6

2

14

9503N
9503F

INST_95_4A_1
INST_95_6

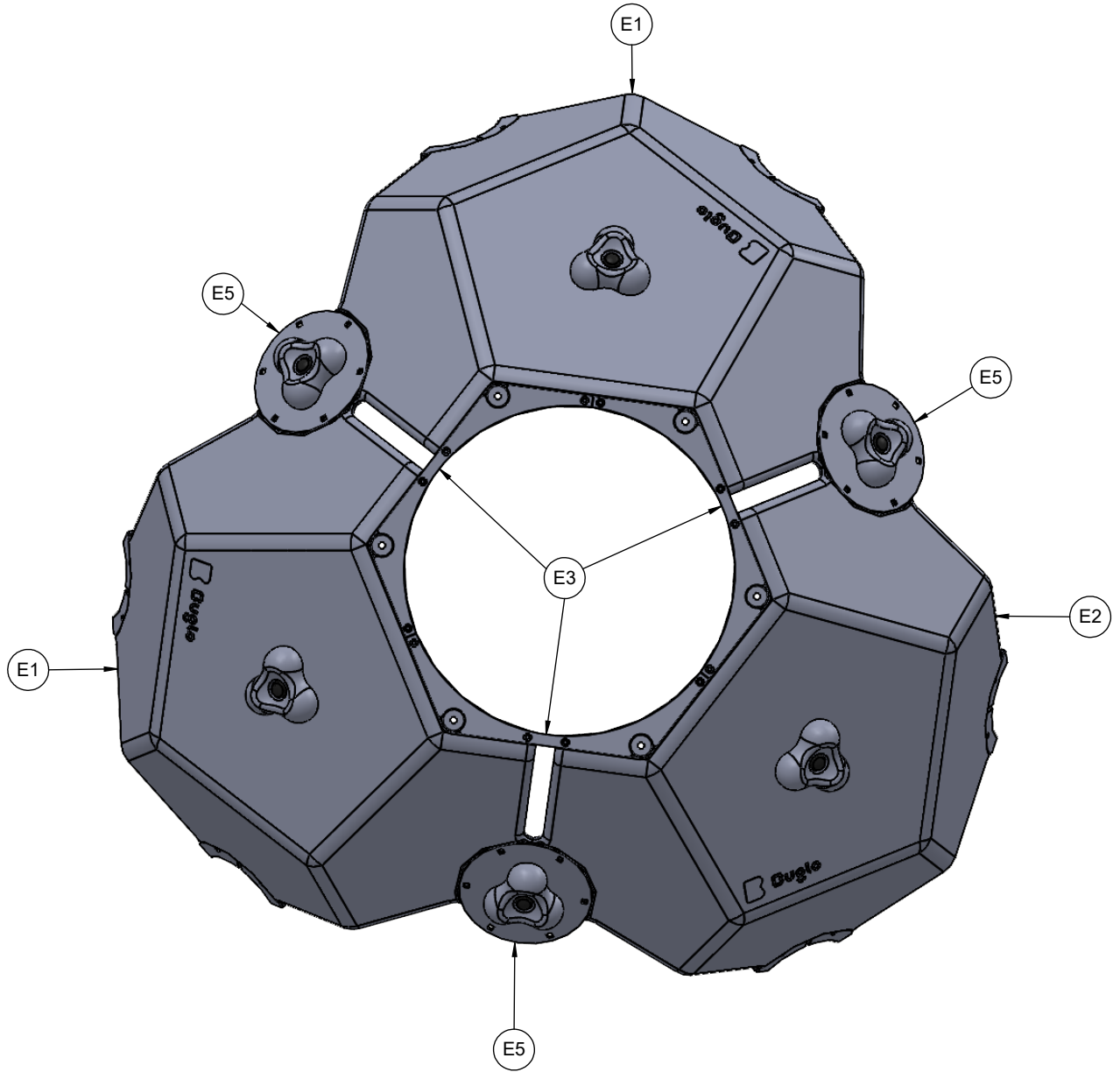

15

9503N
9503F

INST_95_4A_2

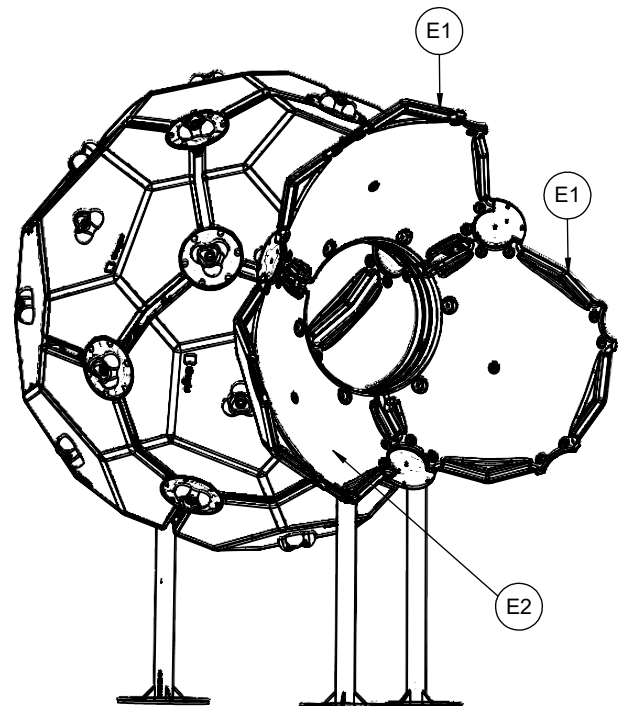
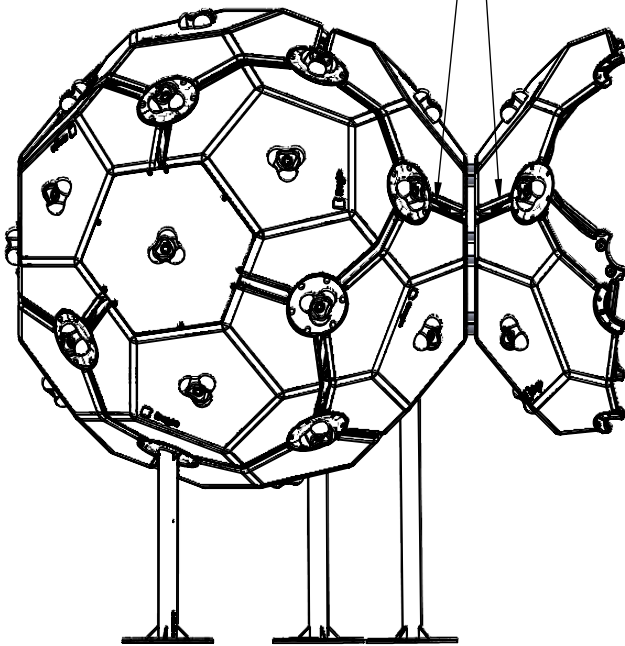
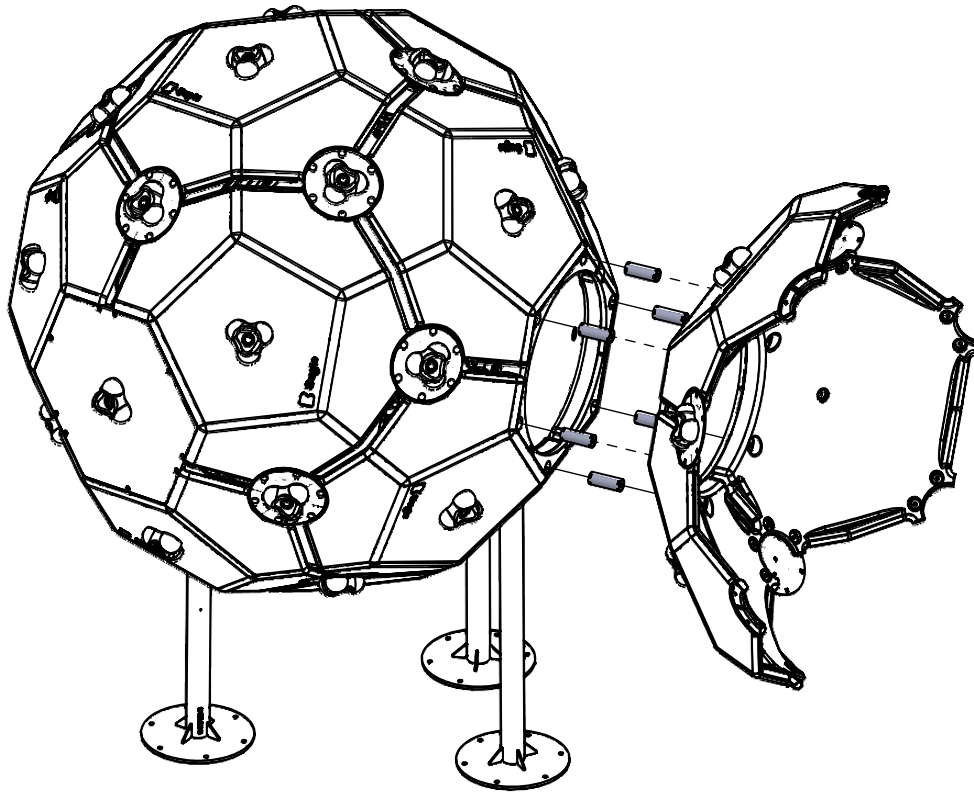

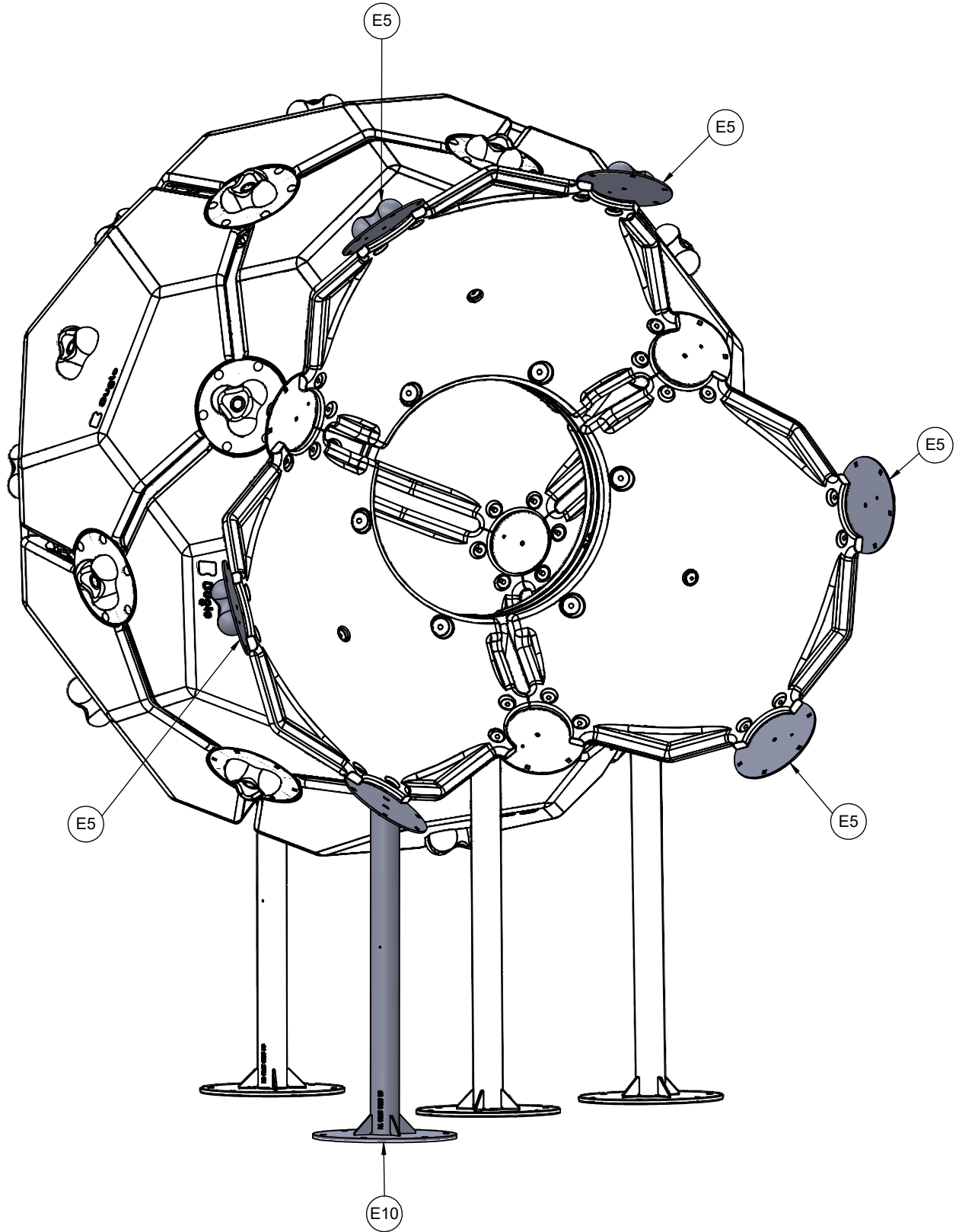

17

9503N
9503F

INST_95_1
INST_95_2
INST_95_6

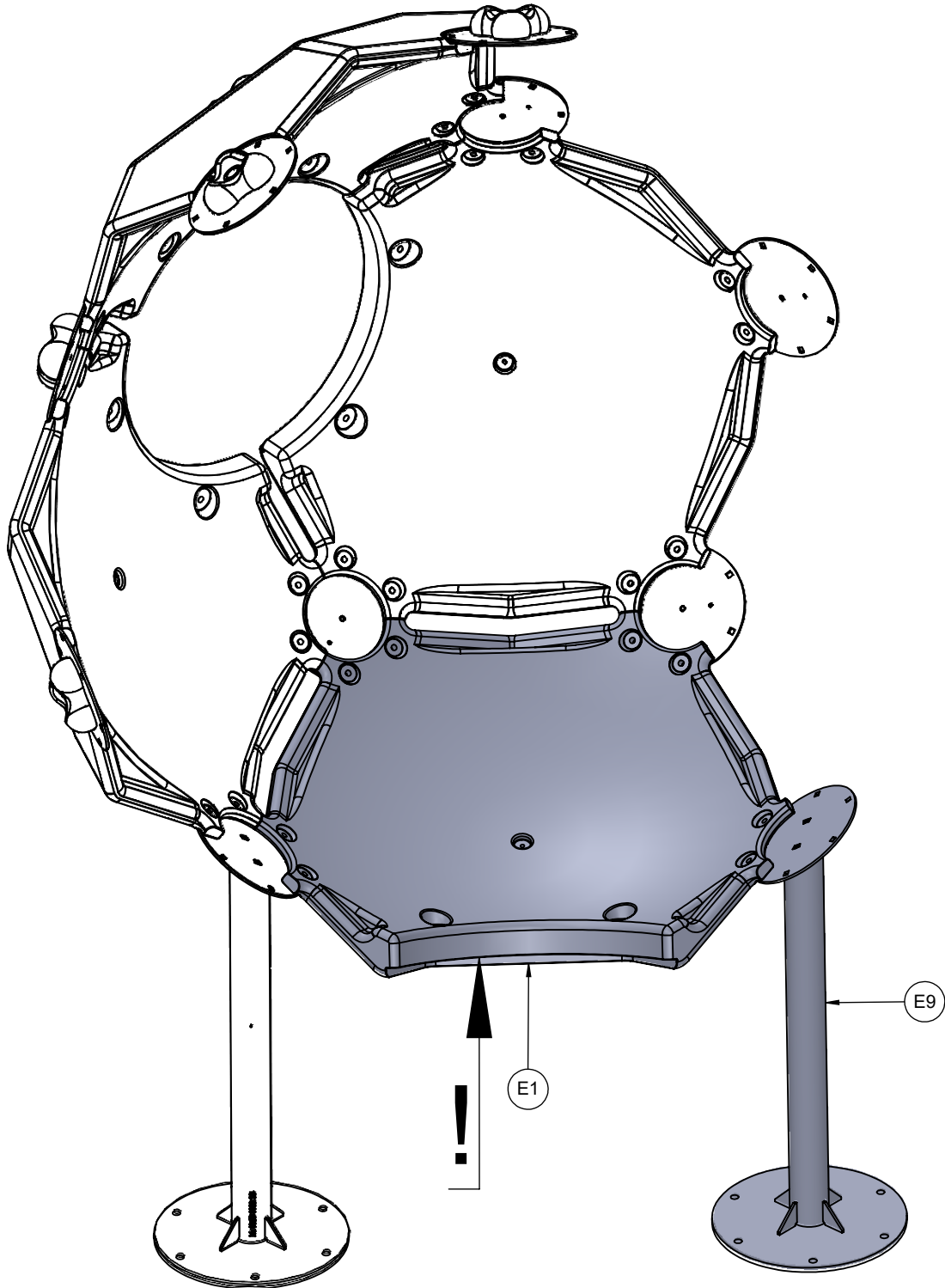

18

9503N
9503F

INST_95_1
INST_95_2
INST_95_6

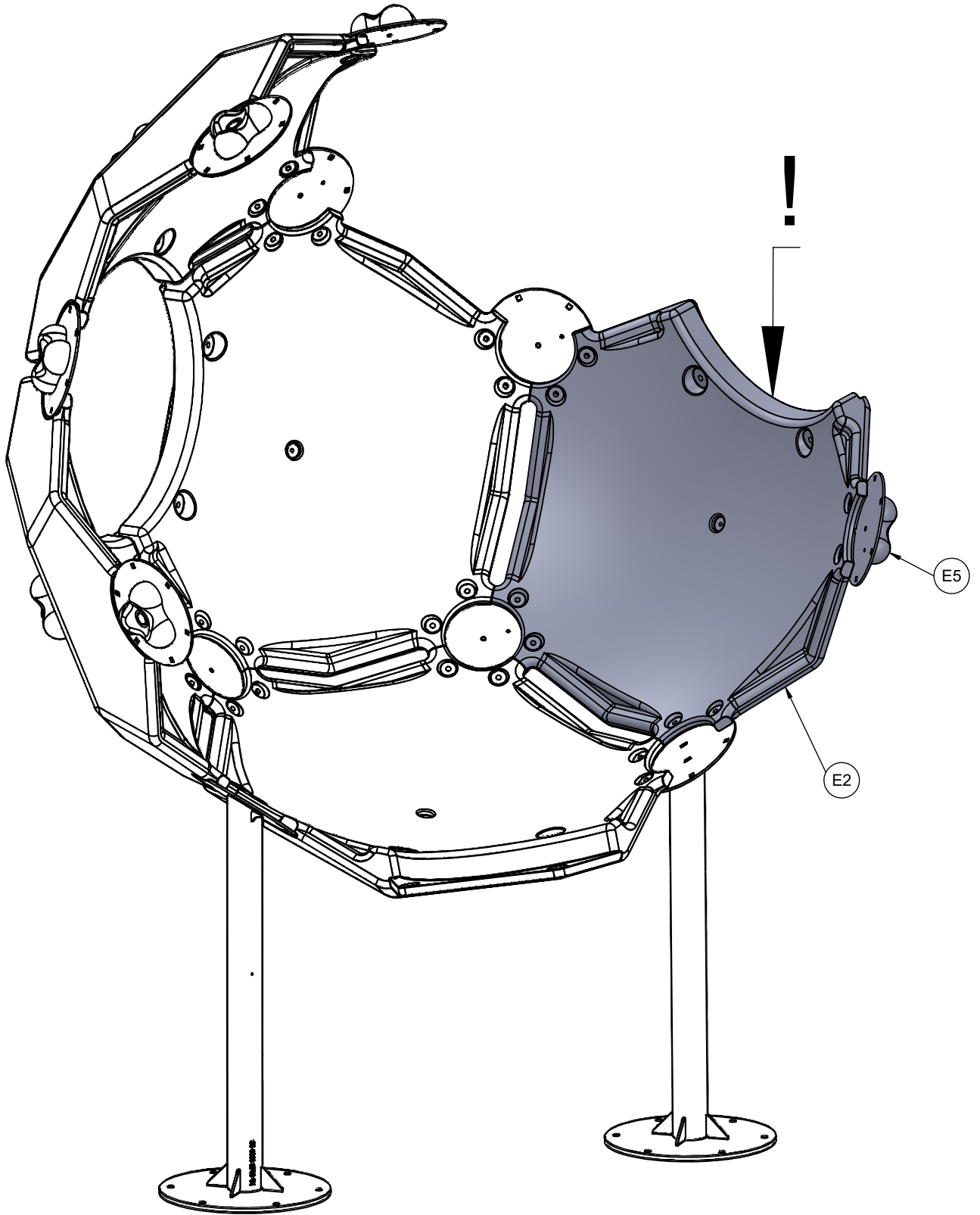

19

9503N
9503F

INST_95_1
INST_95_4B
INST_95_6

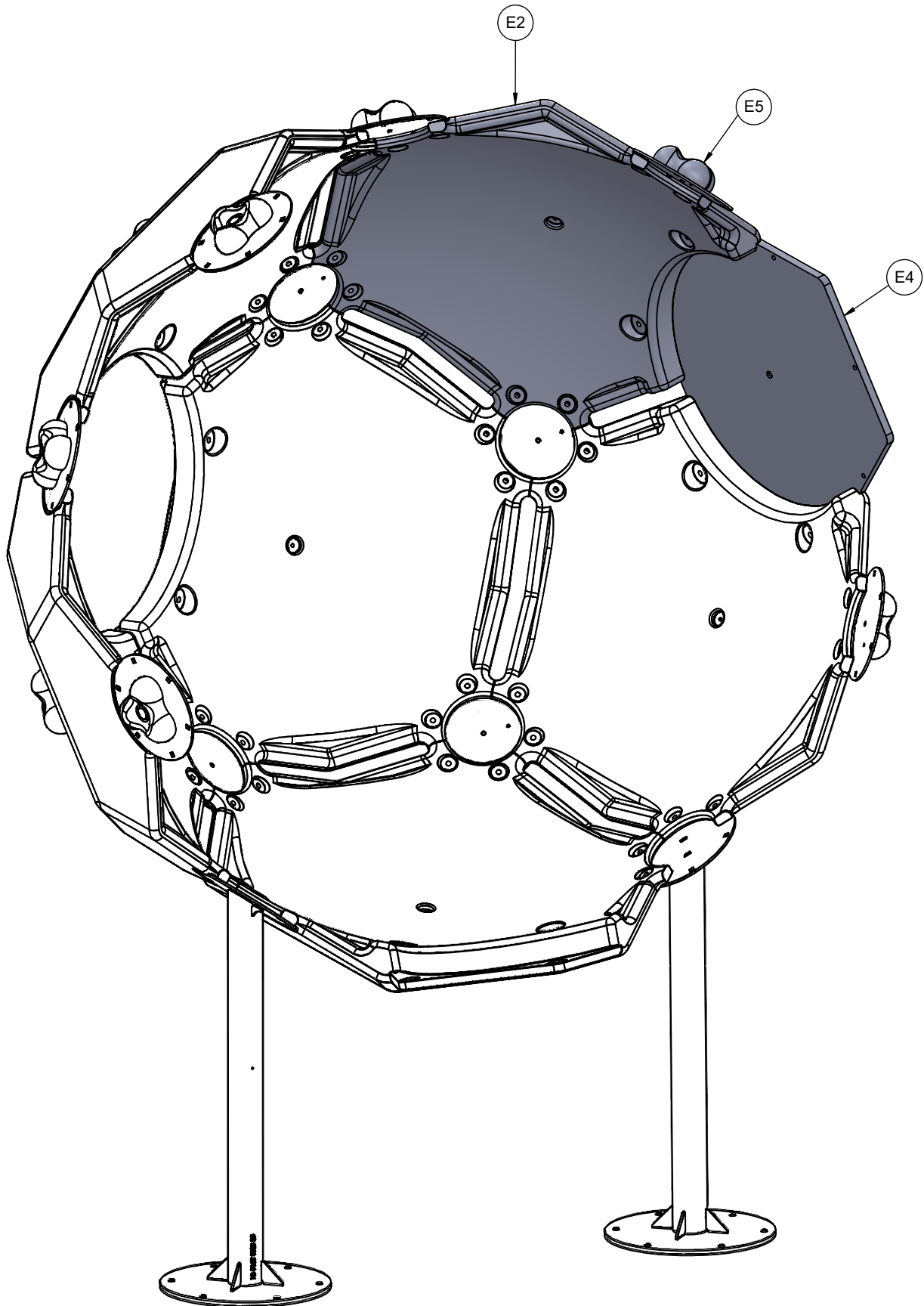

20

9503N
9503F

INST_95_1
INST_95_2
INST_95_4B
INST_95_6

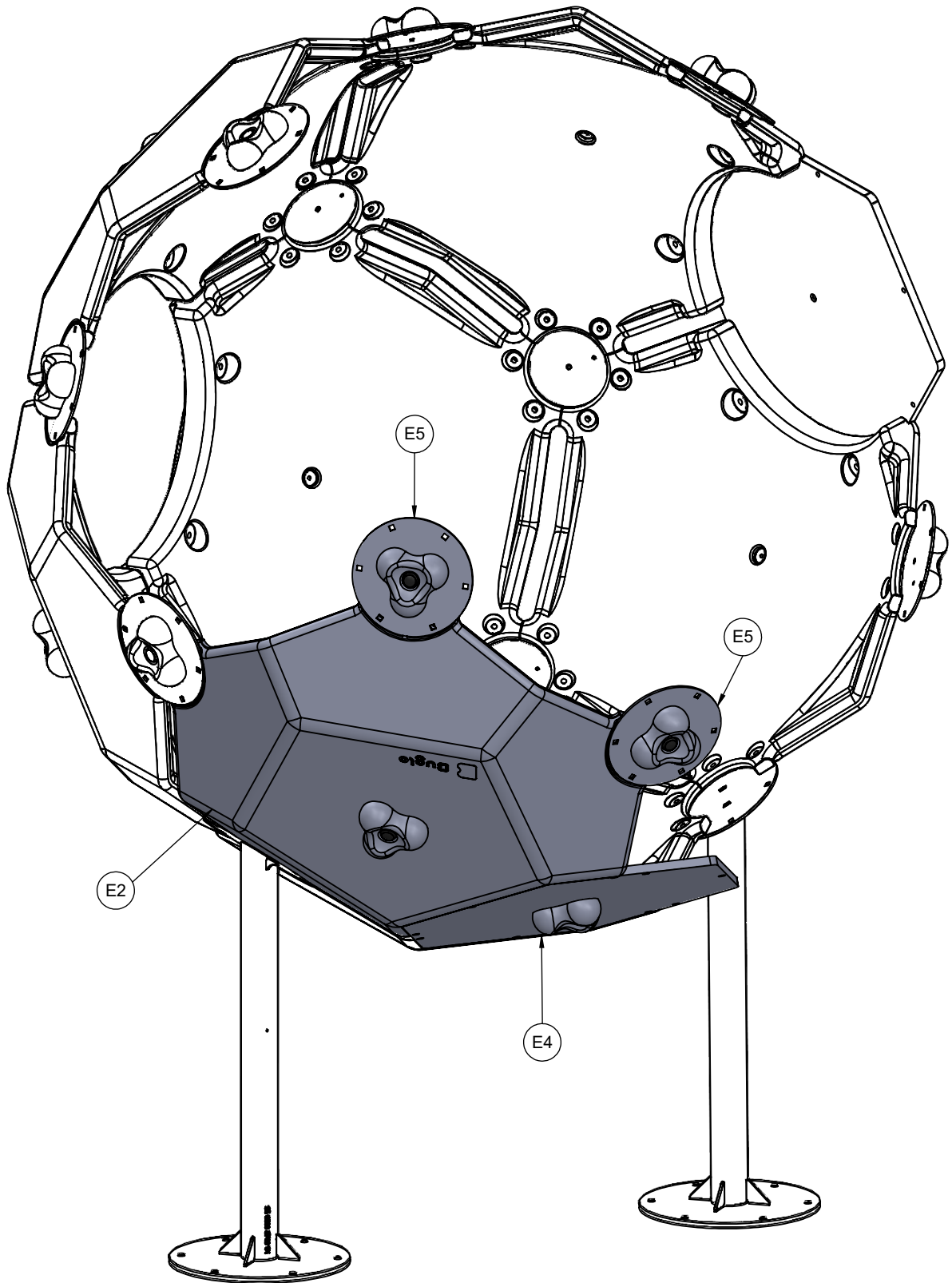

21

9503N
9503F

INST_95_1
INST_95_2
INST_95_4B
INST_95_6

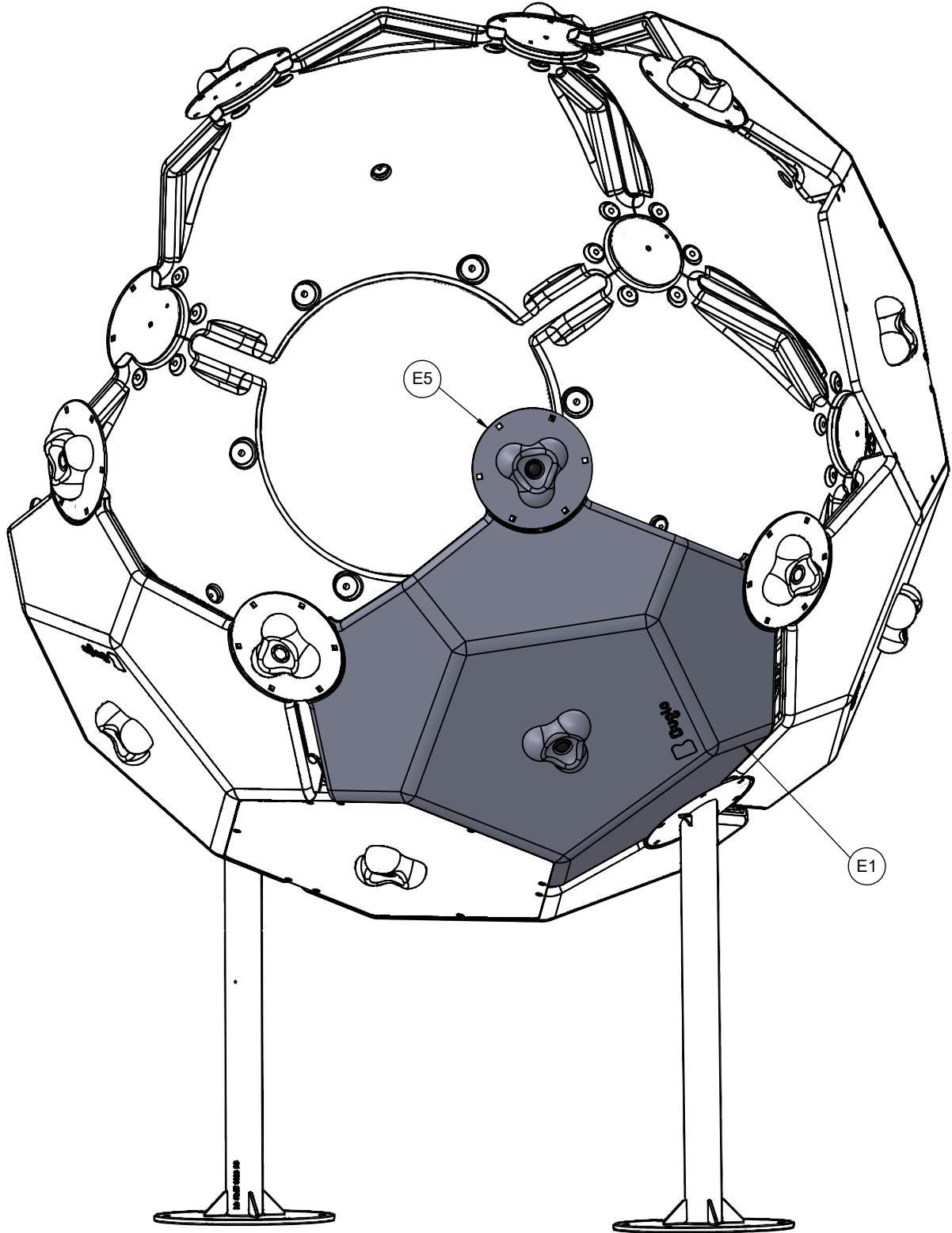

22

9503N
9503F

INST_95_6

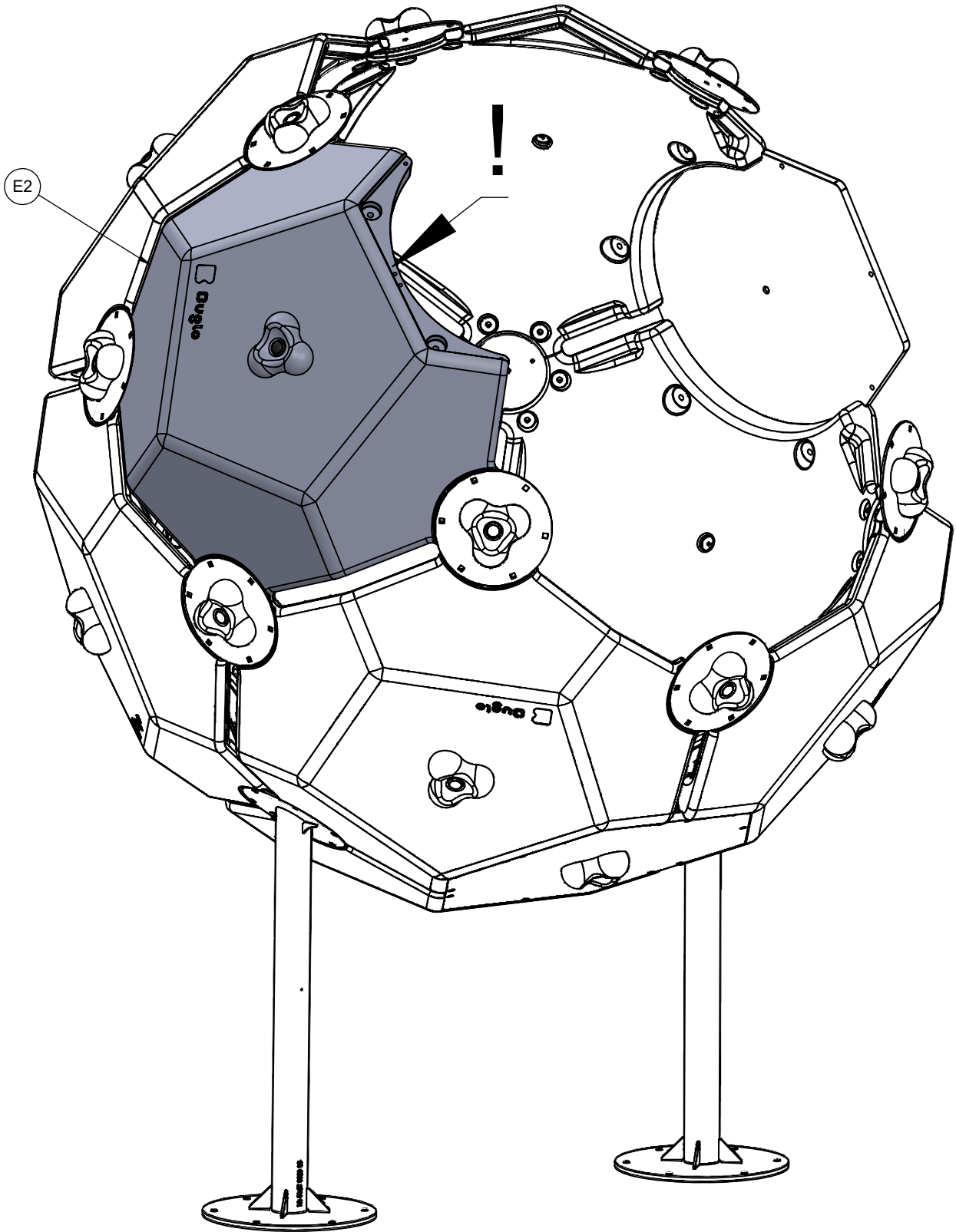

23

9503N
9503F

INST_95_4A_1
INST_95_6

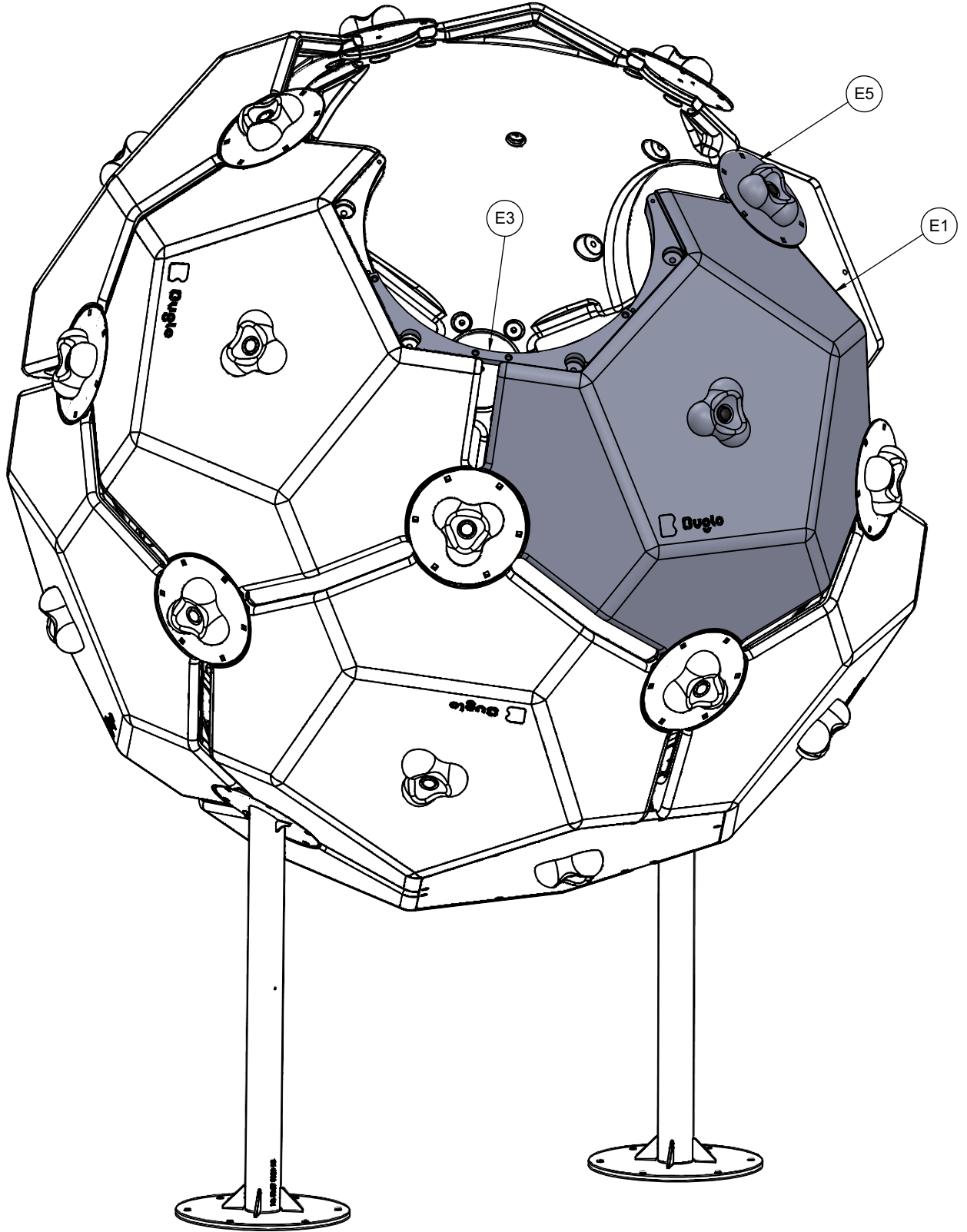

24

9503N
9503F

INST_95_1
INST_95_4B
INST_95_6

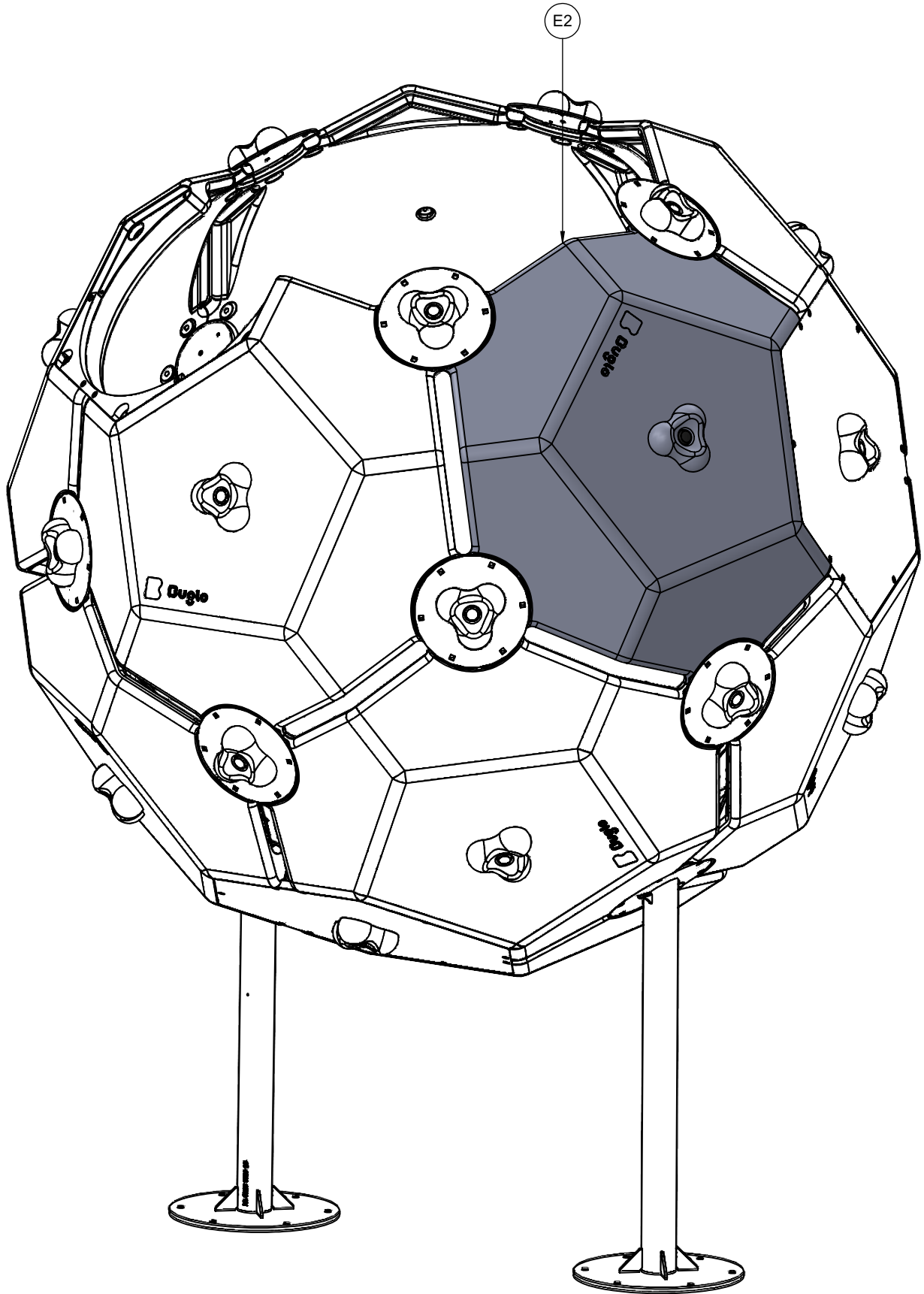

25

9503N
9503F

INST_95_4A_1
INST_95_6

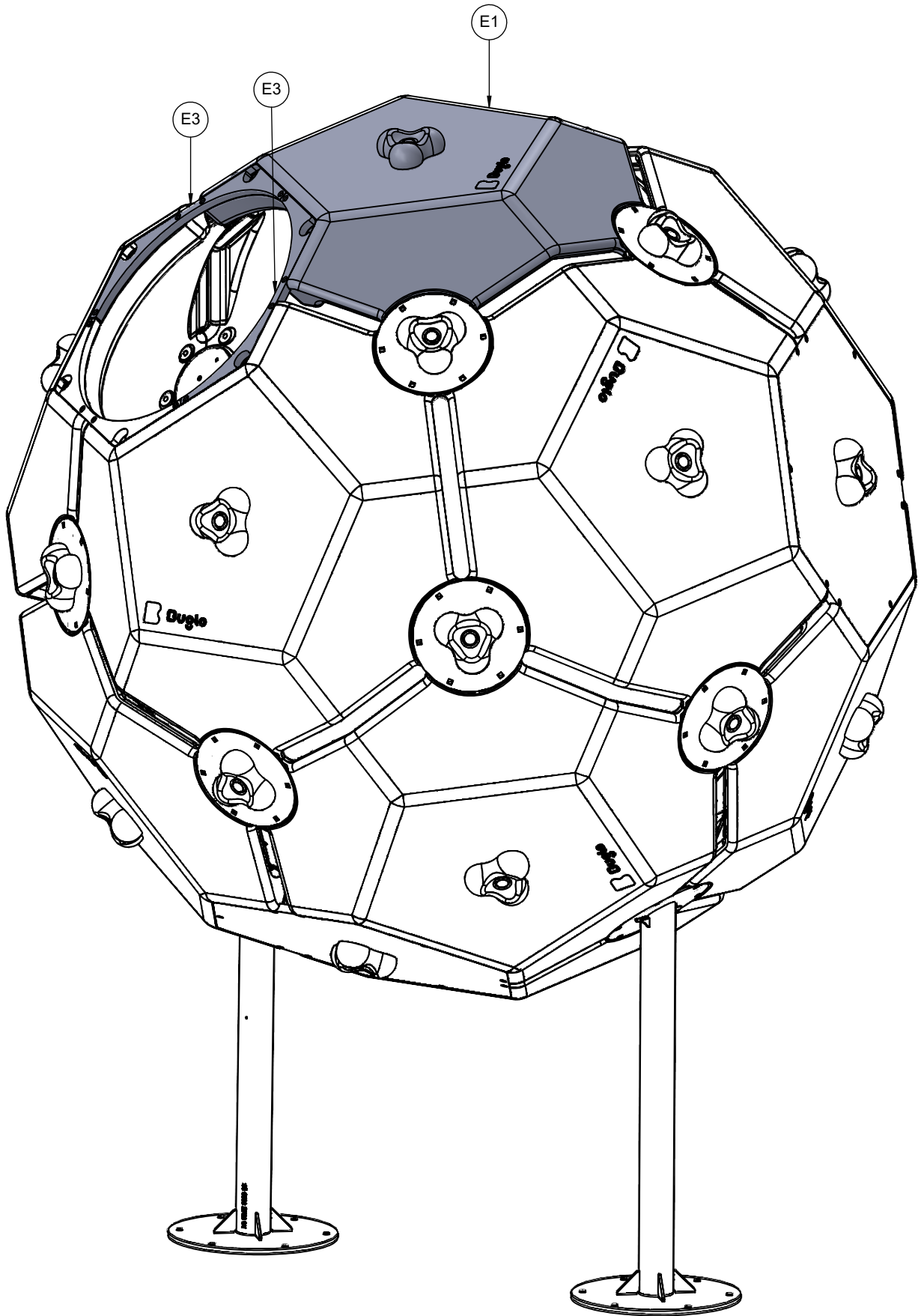

26

9503N
9503F

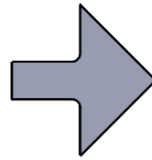
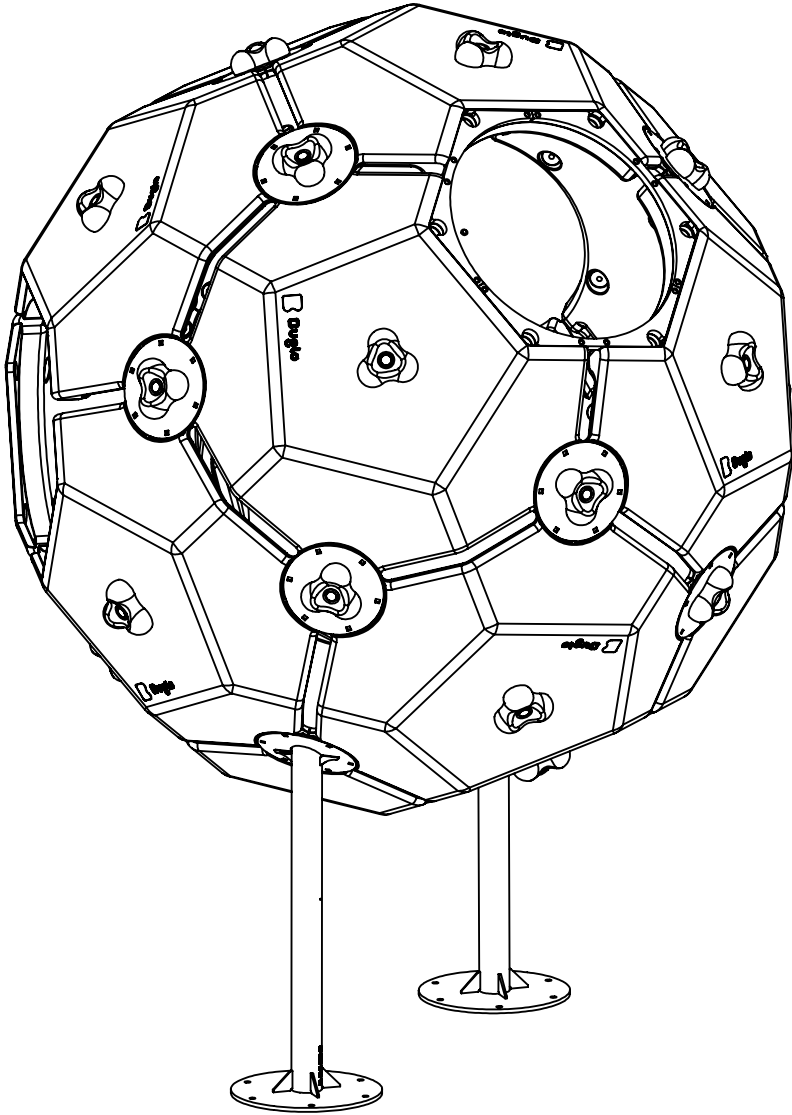

INST_95_2

2

INST_95_6

2

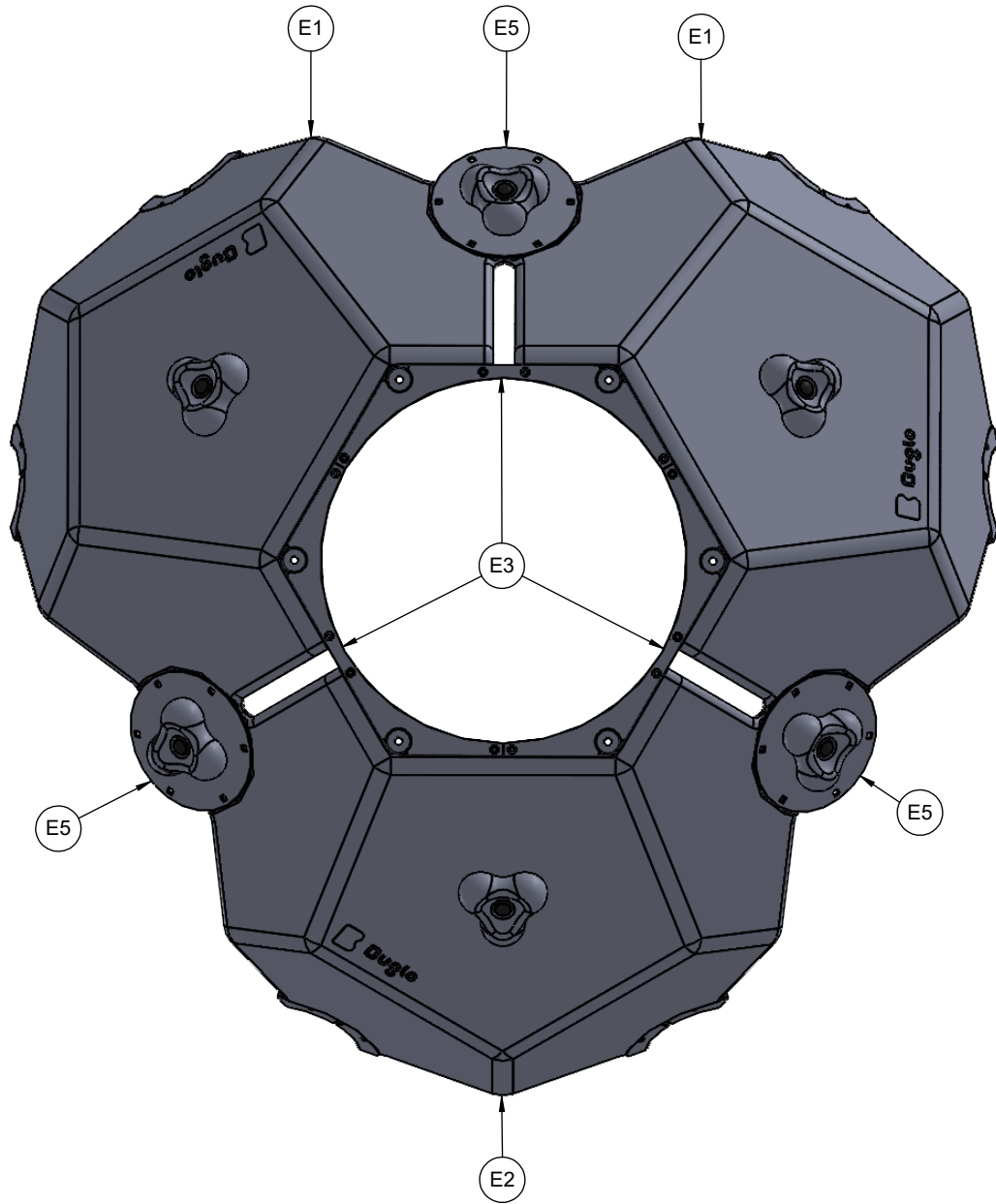

28

9503N
9503F

INST_95_4A_2

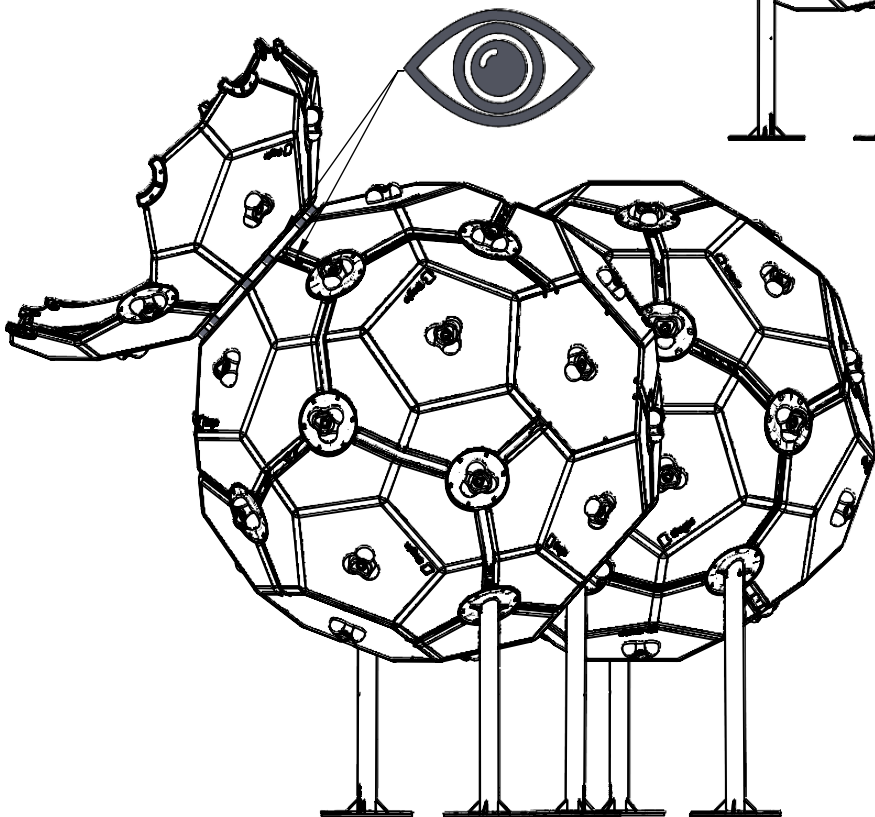
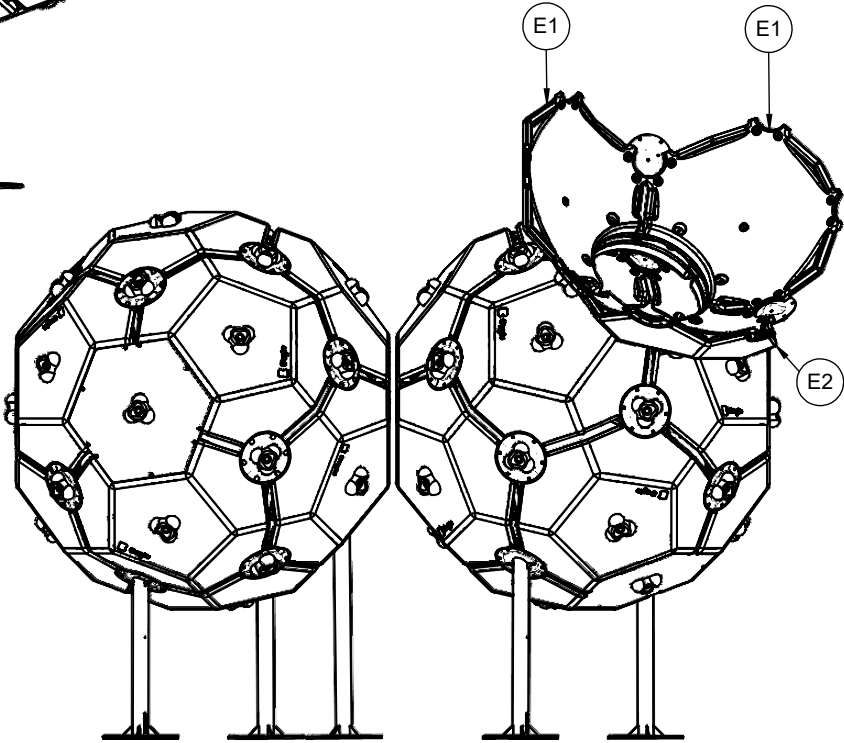
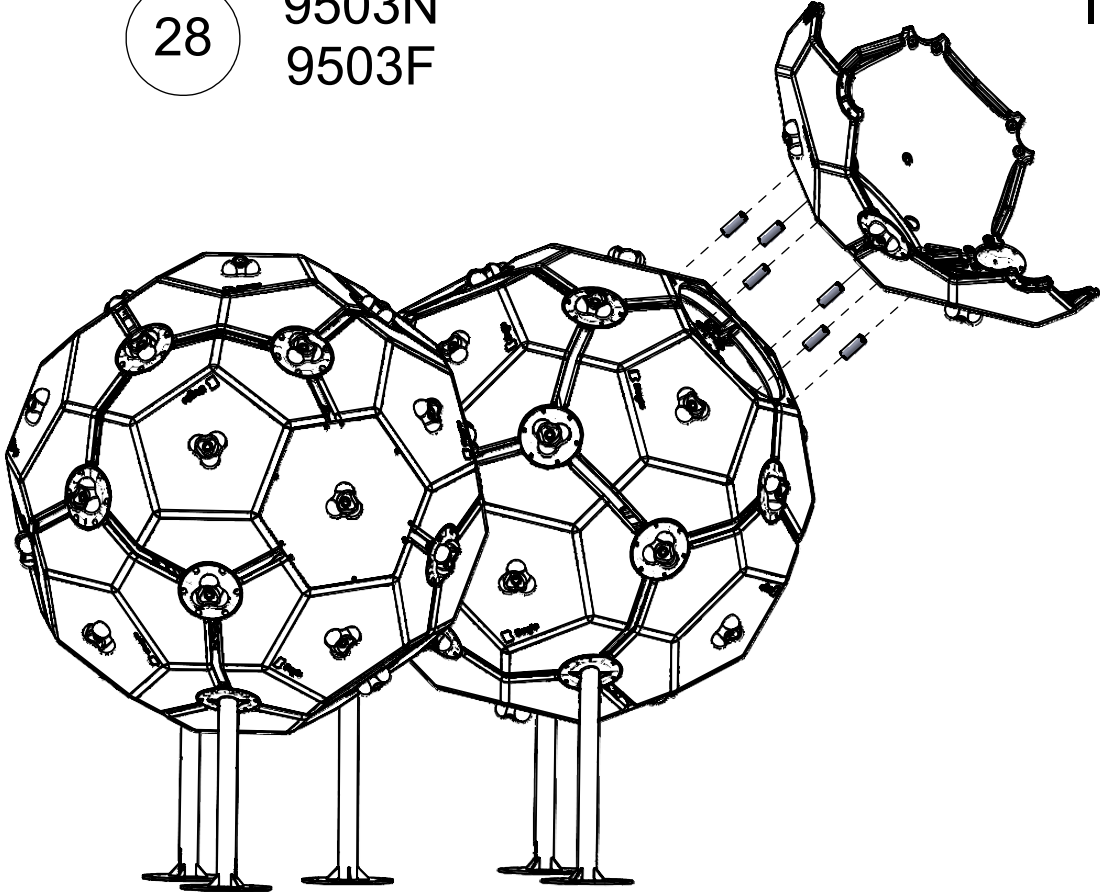

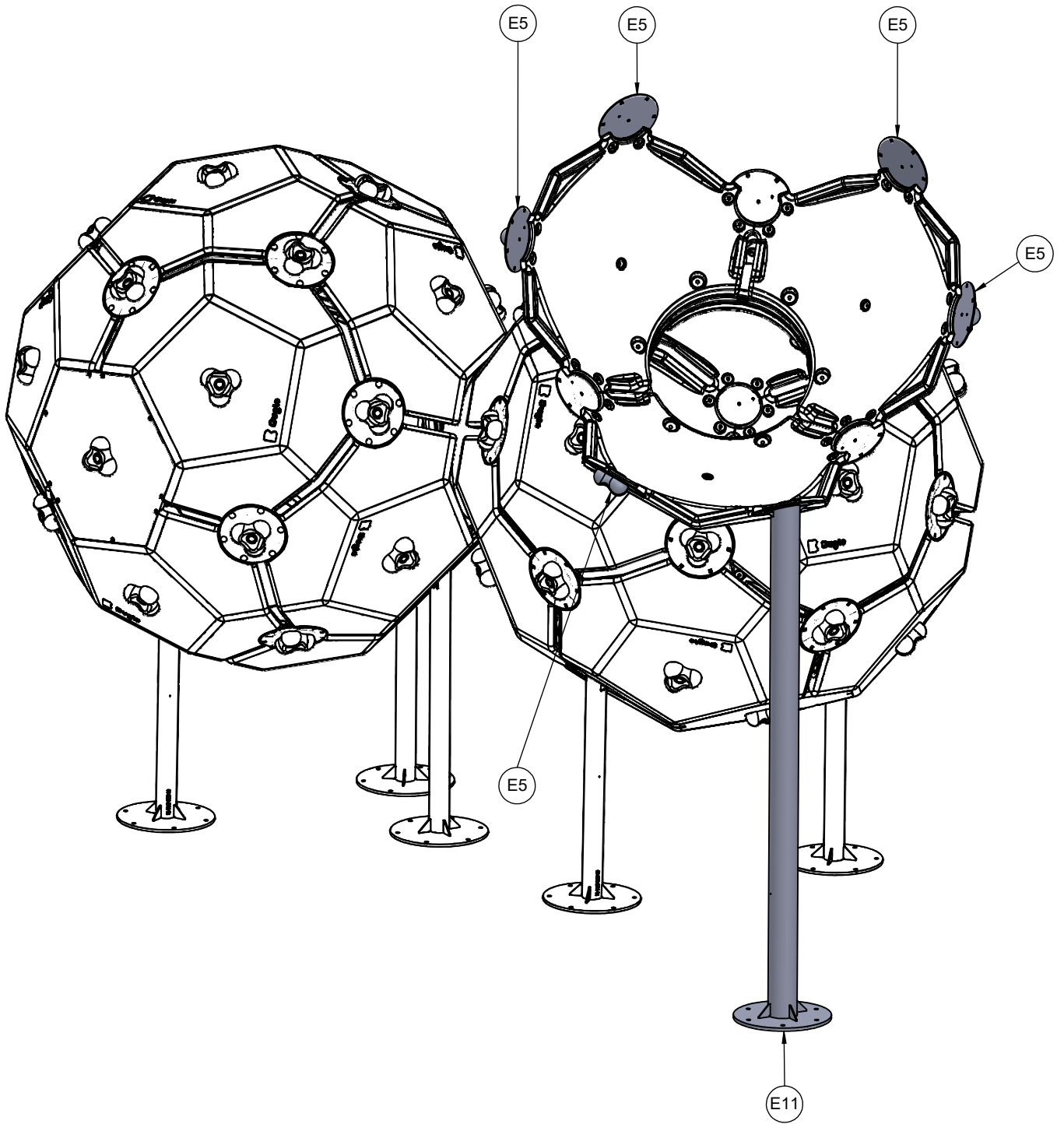

30

9503N
9503F

INST_95_1
INST_95_2
INST_95_6

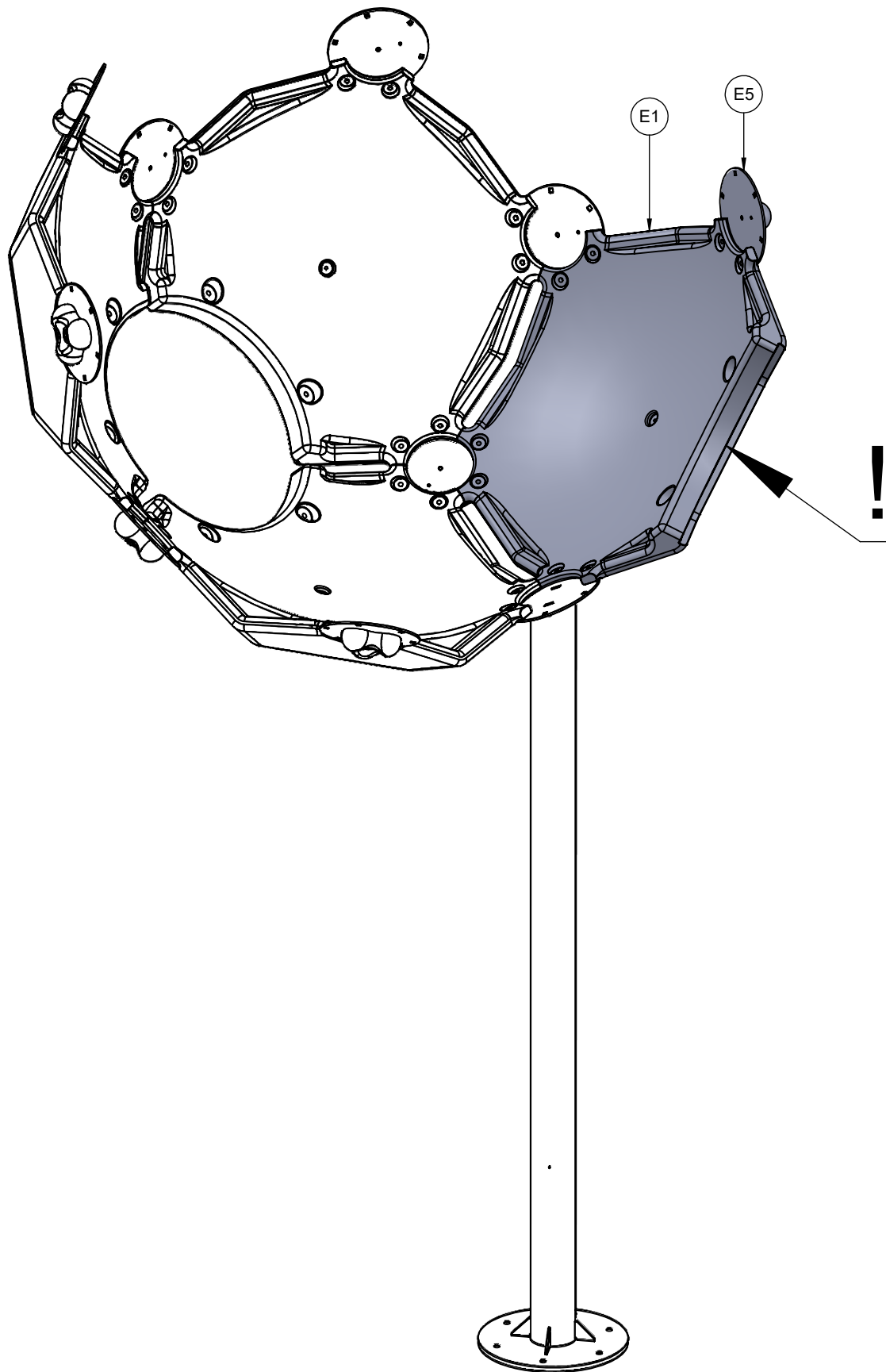

31

9503N
9503F

INST_95_1
INST_95_6

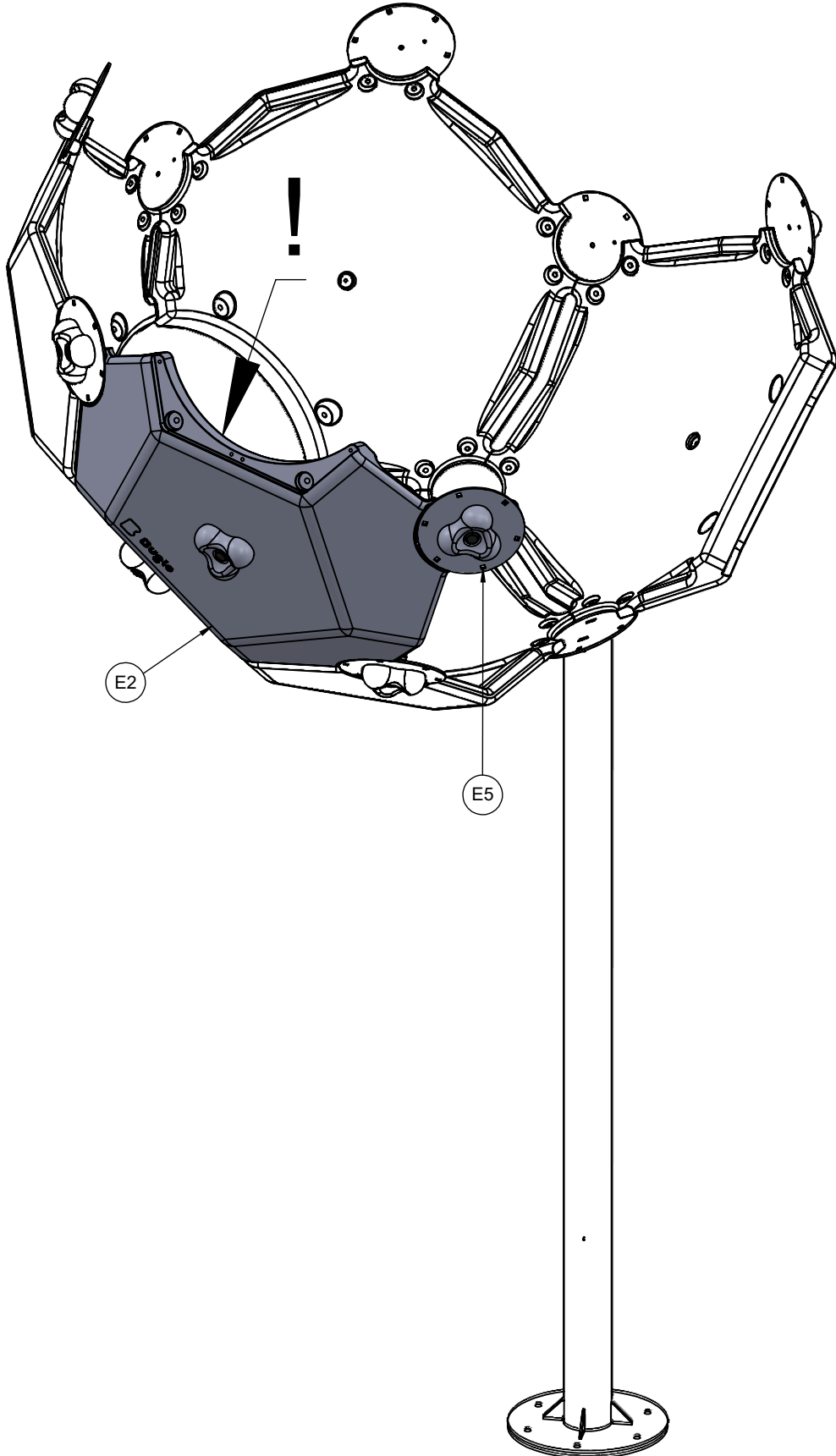

32

9503N
9503F

INST_95_1
INST_95_2
INST_95_6

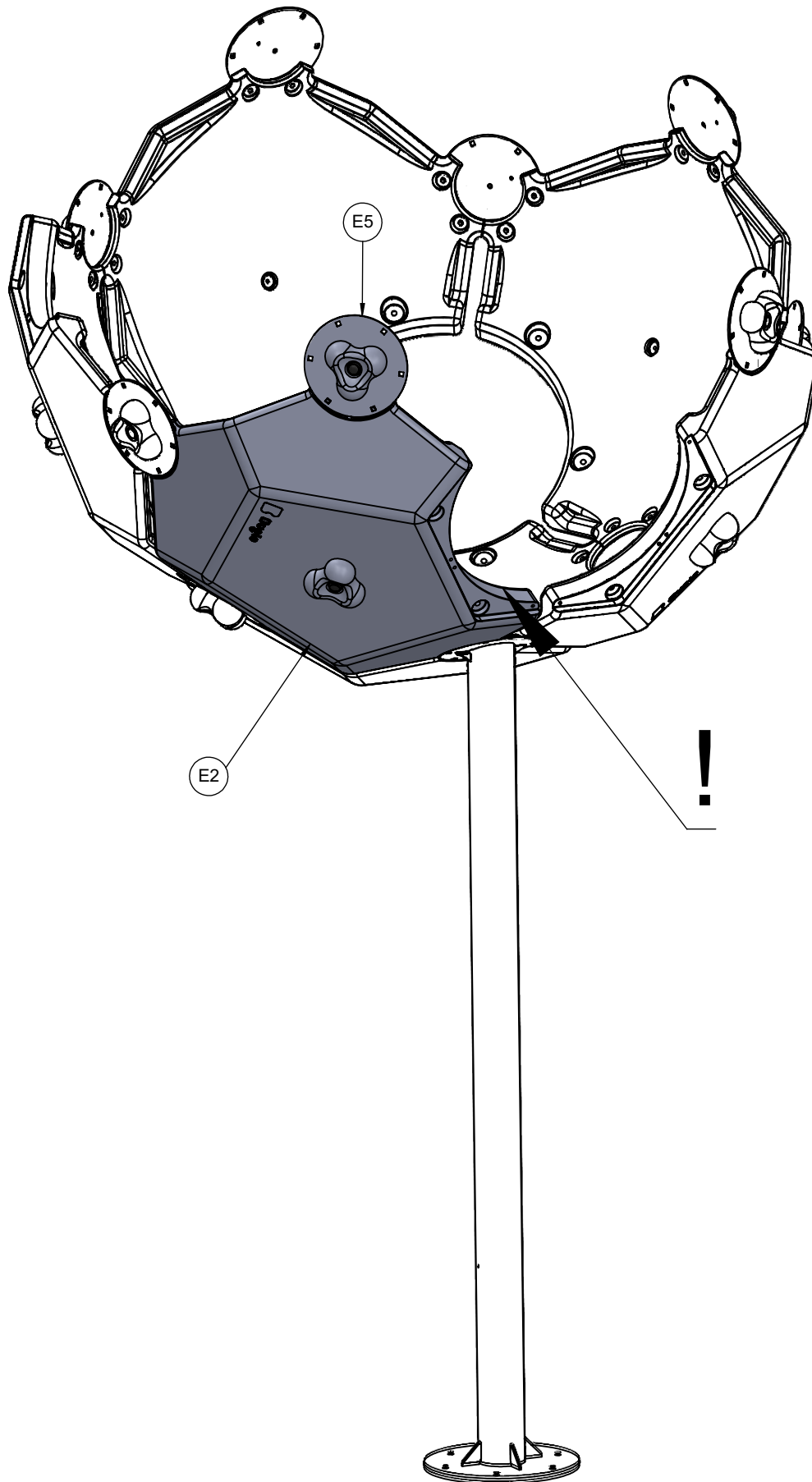

33

9503N
9503F

INST_95_1
INST_95_6

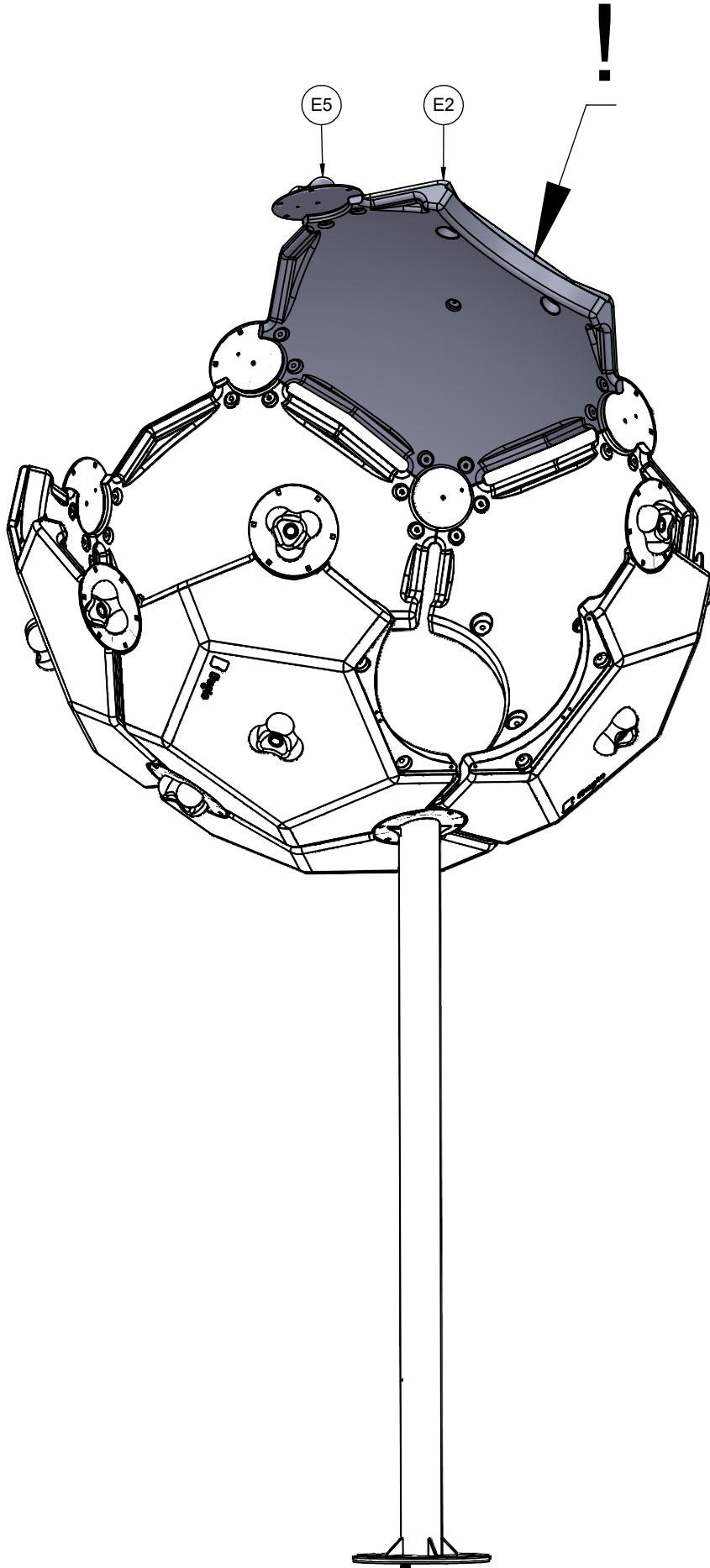

34

9503N
9503F

INST_95_1
INST_95_4B
INST_95_6

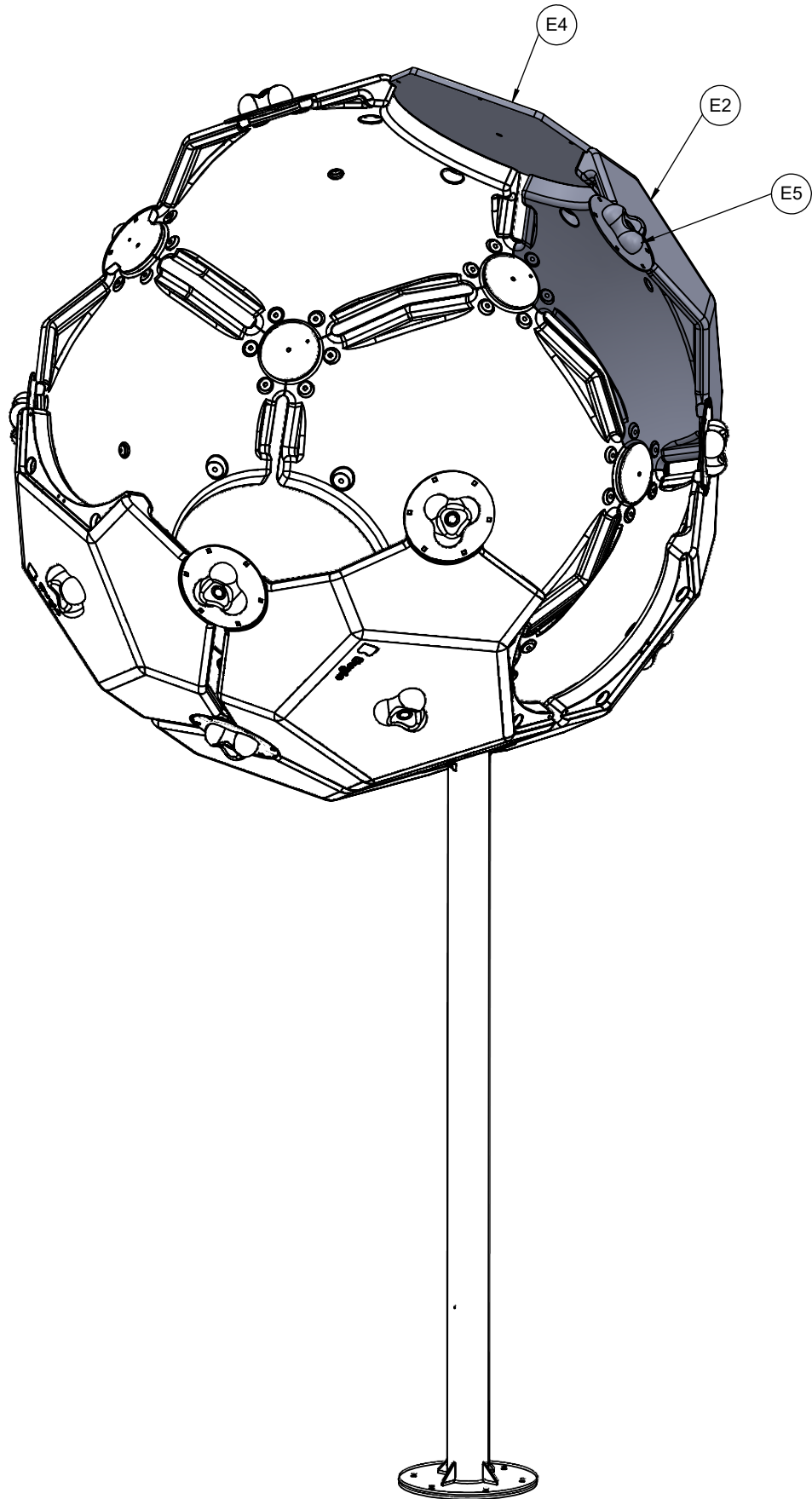

35

9503N
9503F

INST_95_1
INST_95_4B
INST_95_6

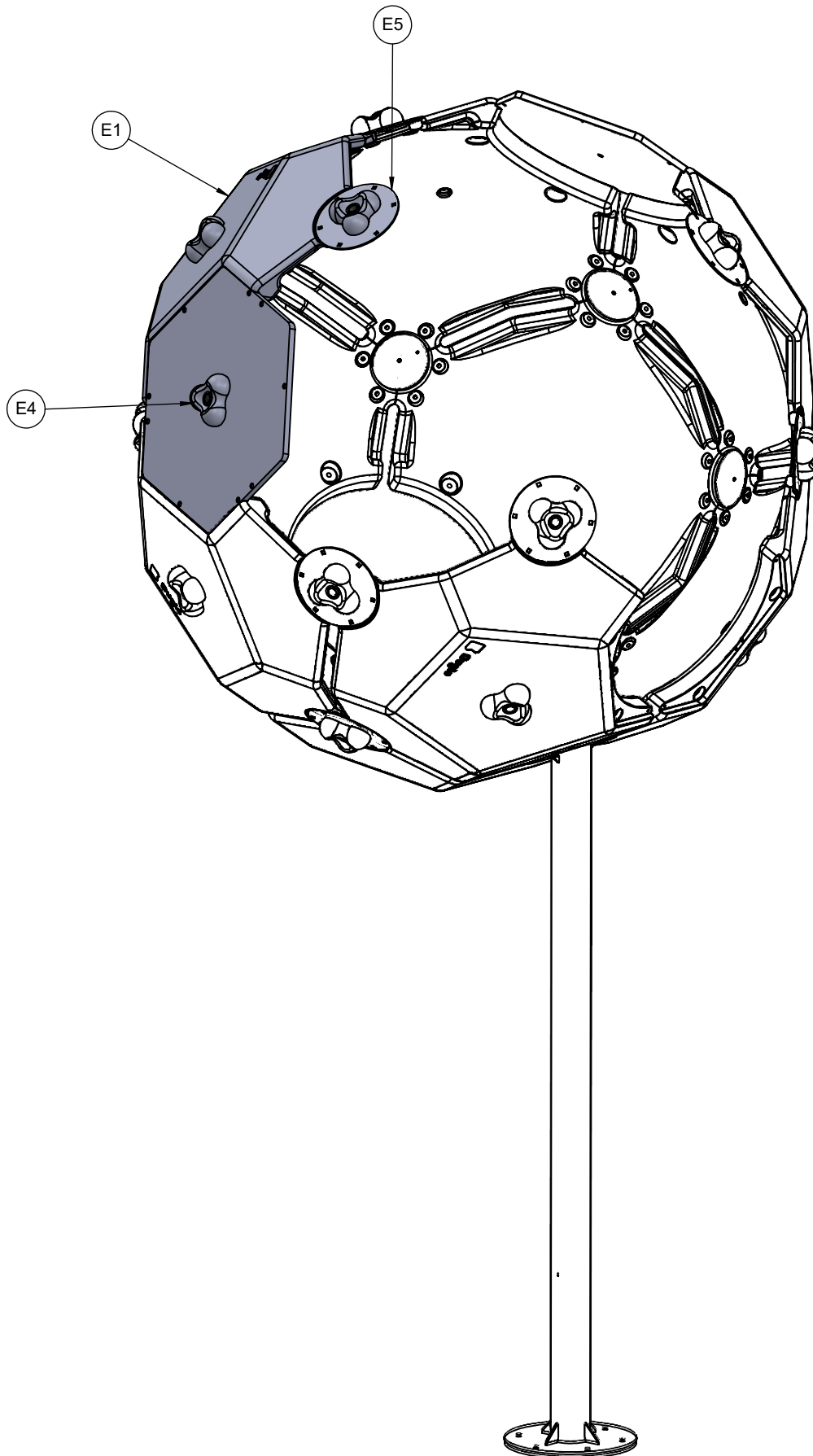

36

9503N
9503F

INST_95_1
INST_95_4B
INST_95_6

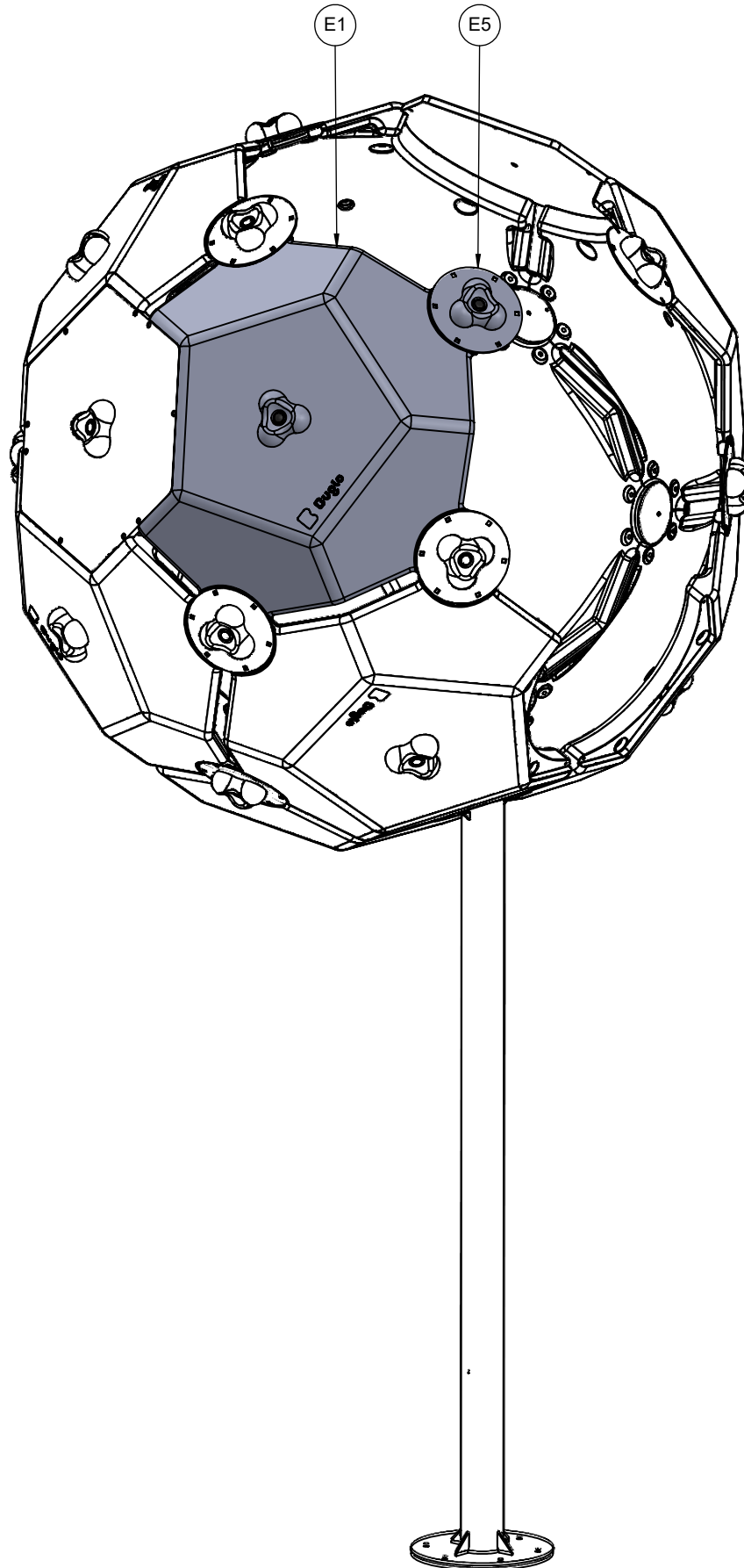

37

9503N
9503F

INST_95_1
INST_95_4B
INST_95_6

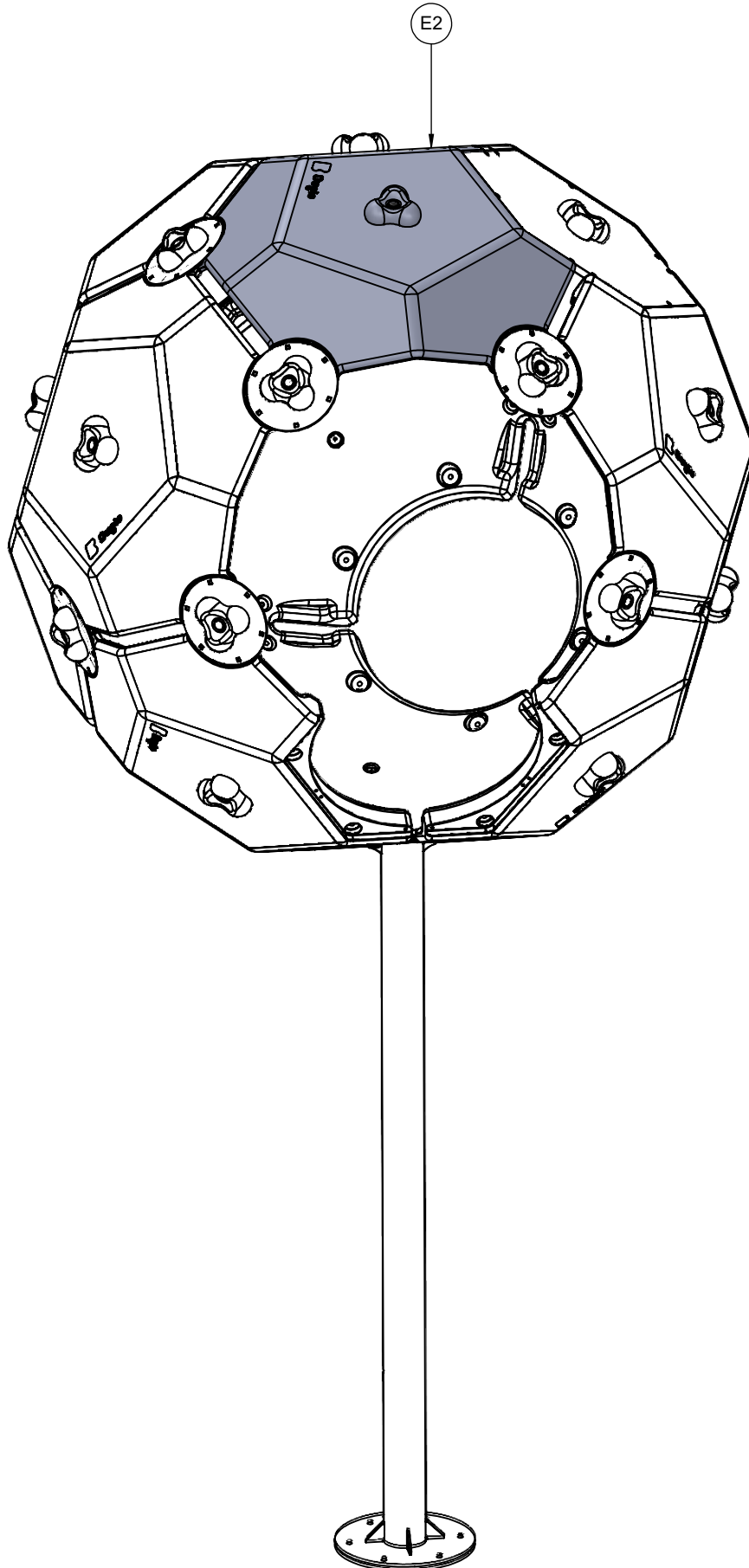

38

9503N
9503F

INST_95_1
INST_95_6

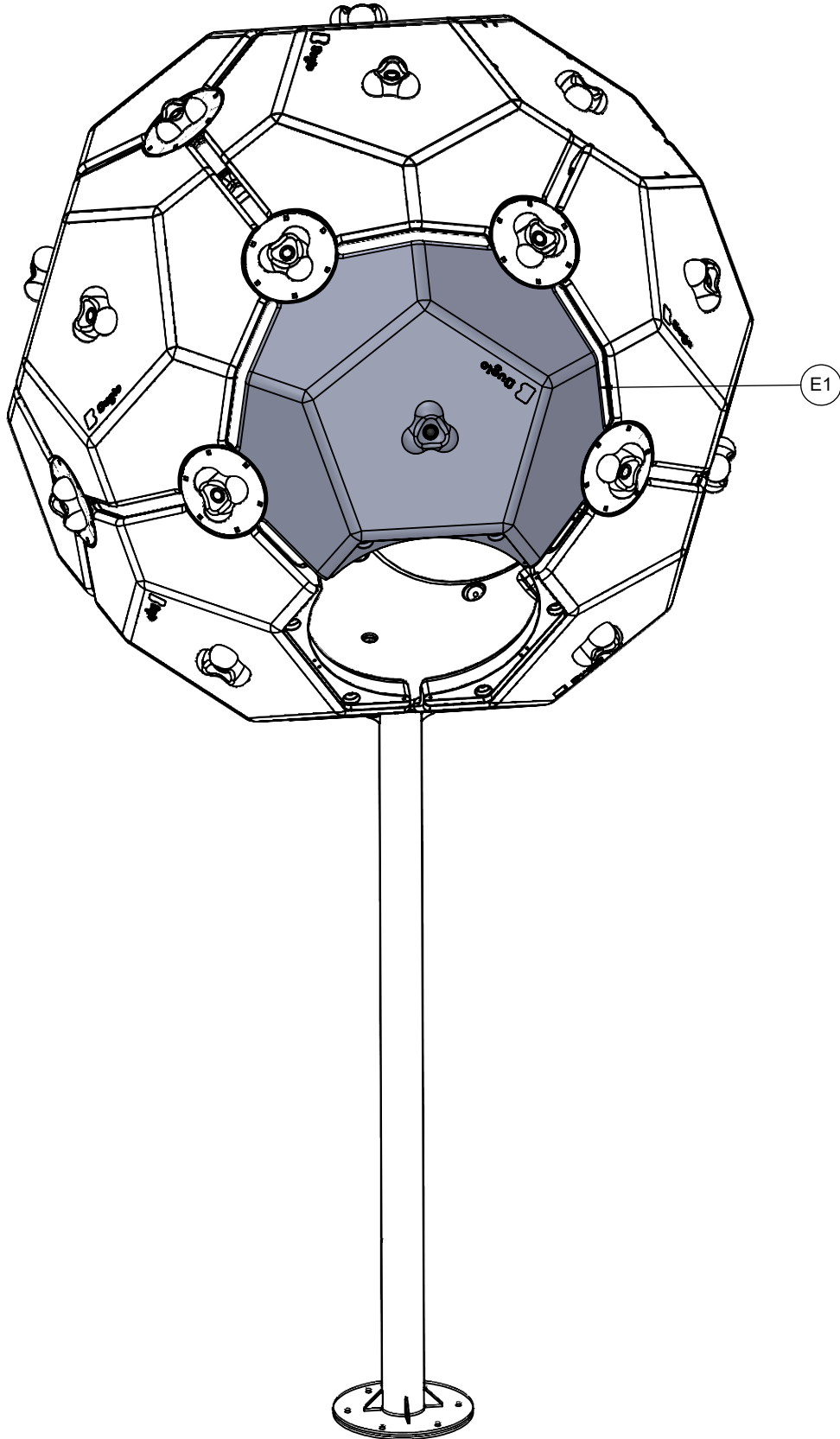

39

9503N
9503F

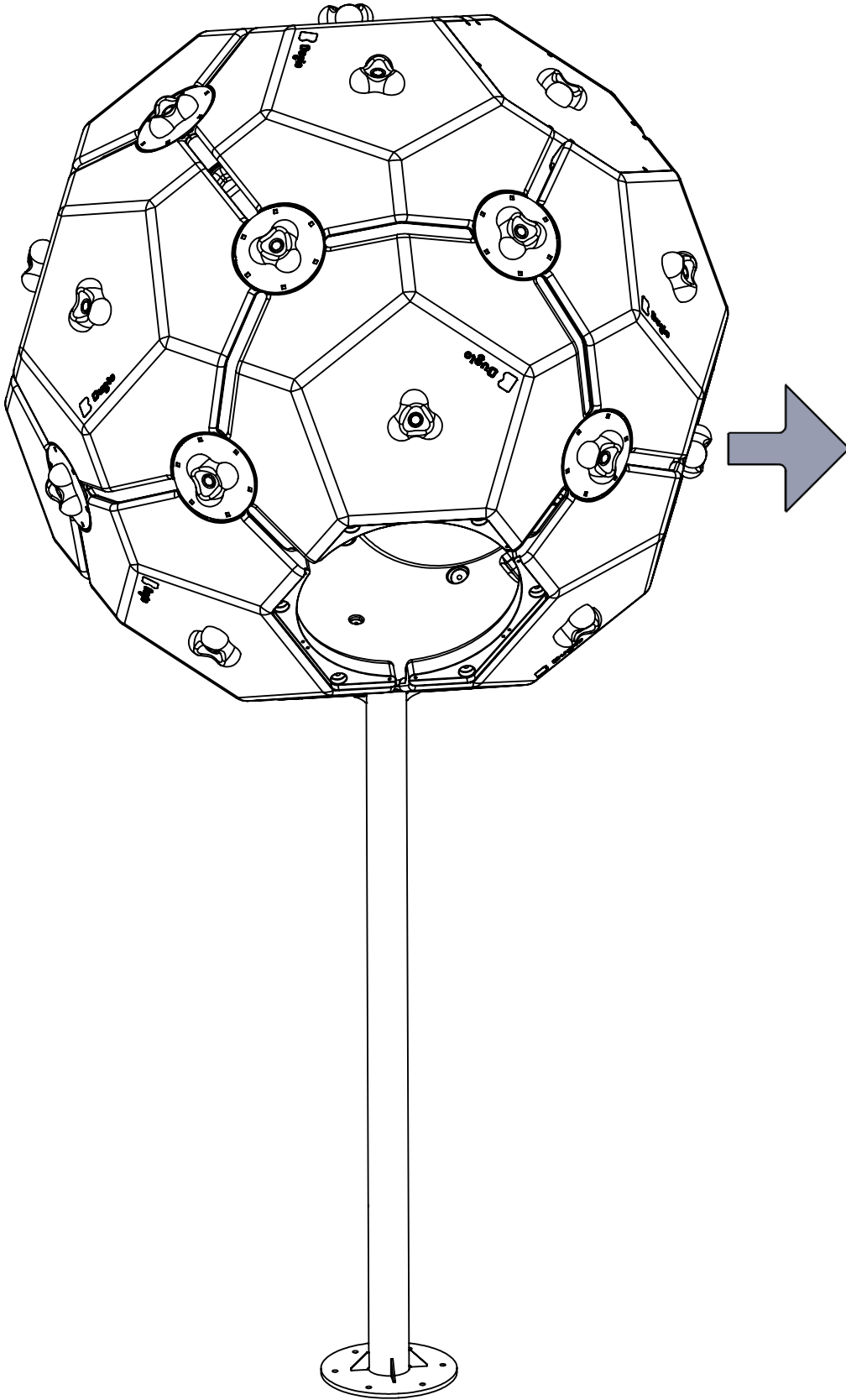

INST_95_2

2

INST_95_6

2

40

9503N
9503F

INST_95_4B

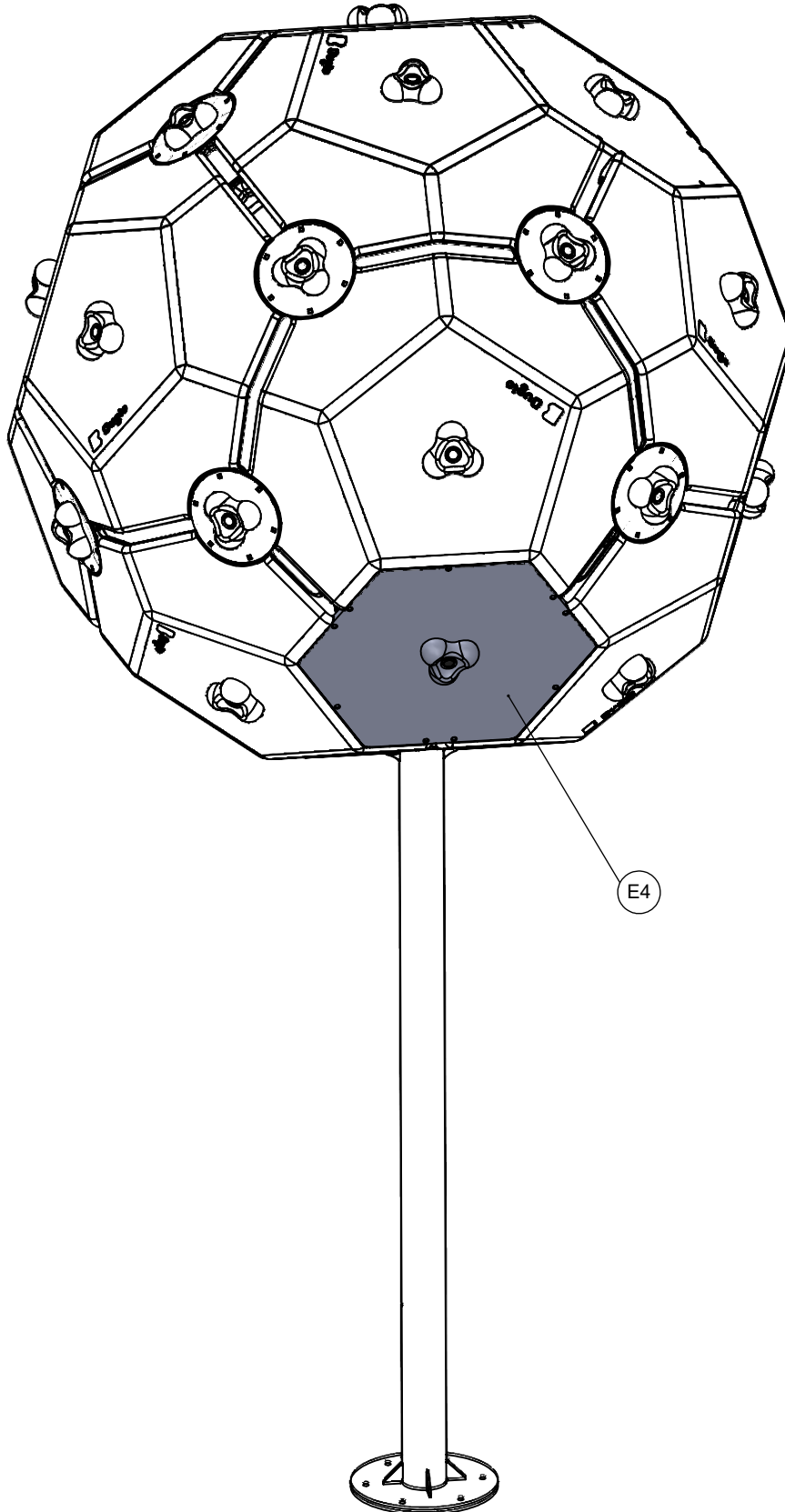

9503N

Nr	Element		
61		-	KL105 (OC)

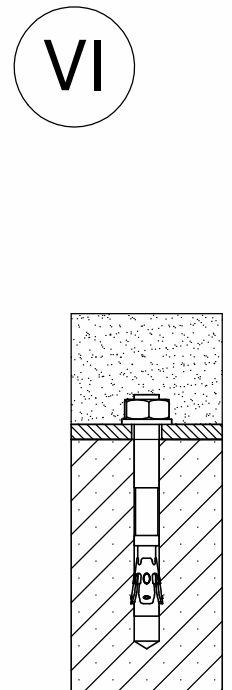
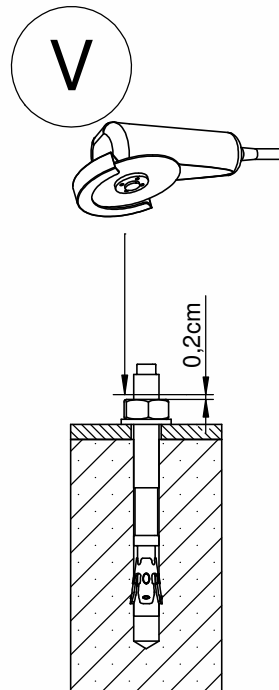
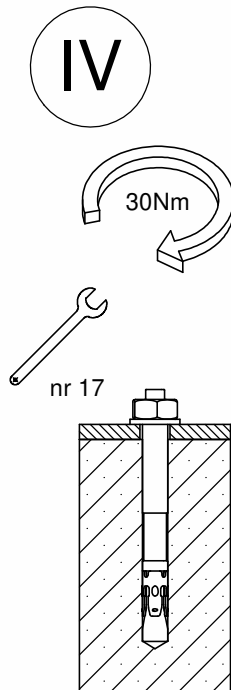
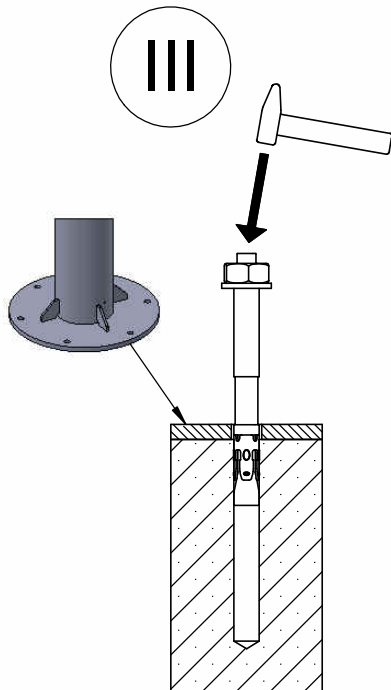
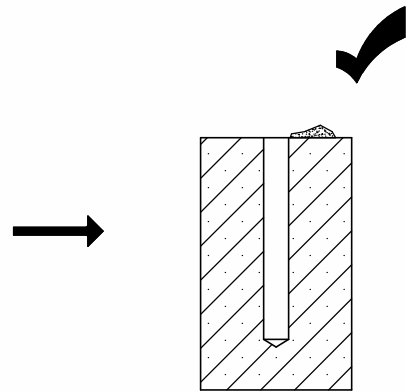
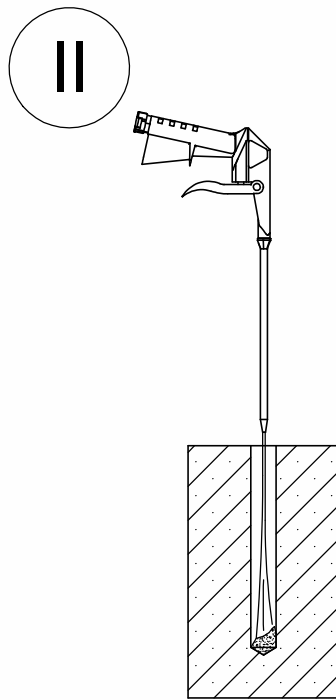
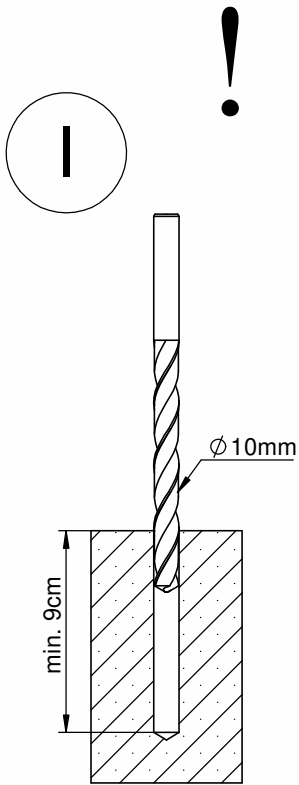
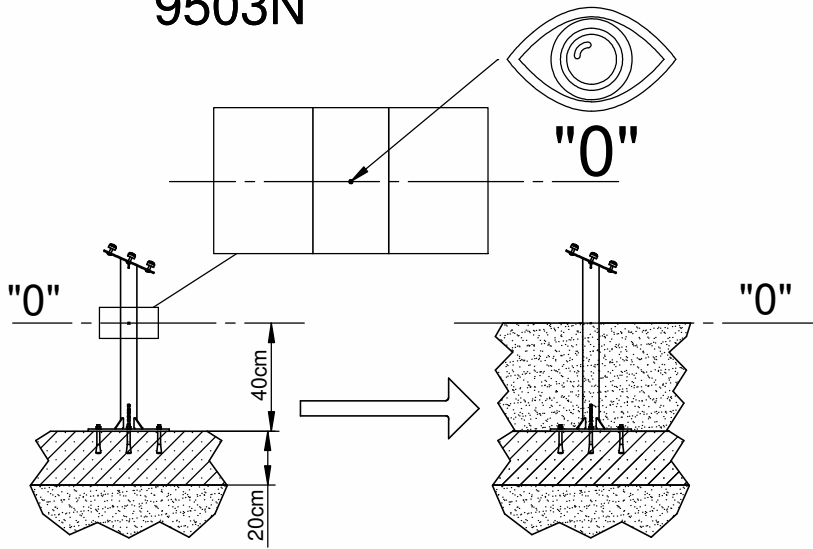

INST_95_1



Nr. 10



Nr. 4

Nr	Σ	Element	DIN	ELEMENT
3	2		-	K2_d30_B
6	2		-	Z2_d30_B
10	4		DIN 9021	6x18
18	2		DIN 985	M6 (OC)
118	2		ISO 7380	M6x50

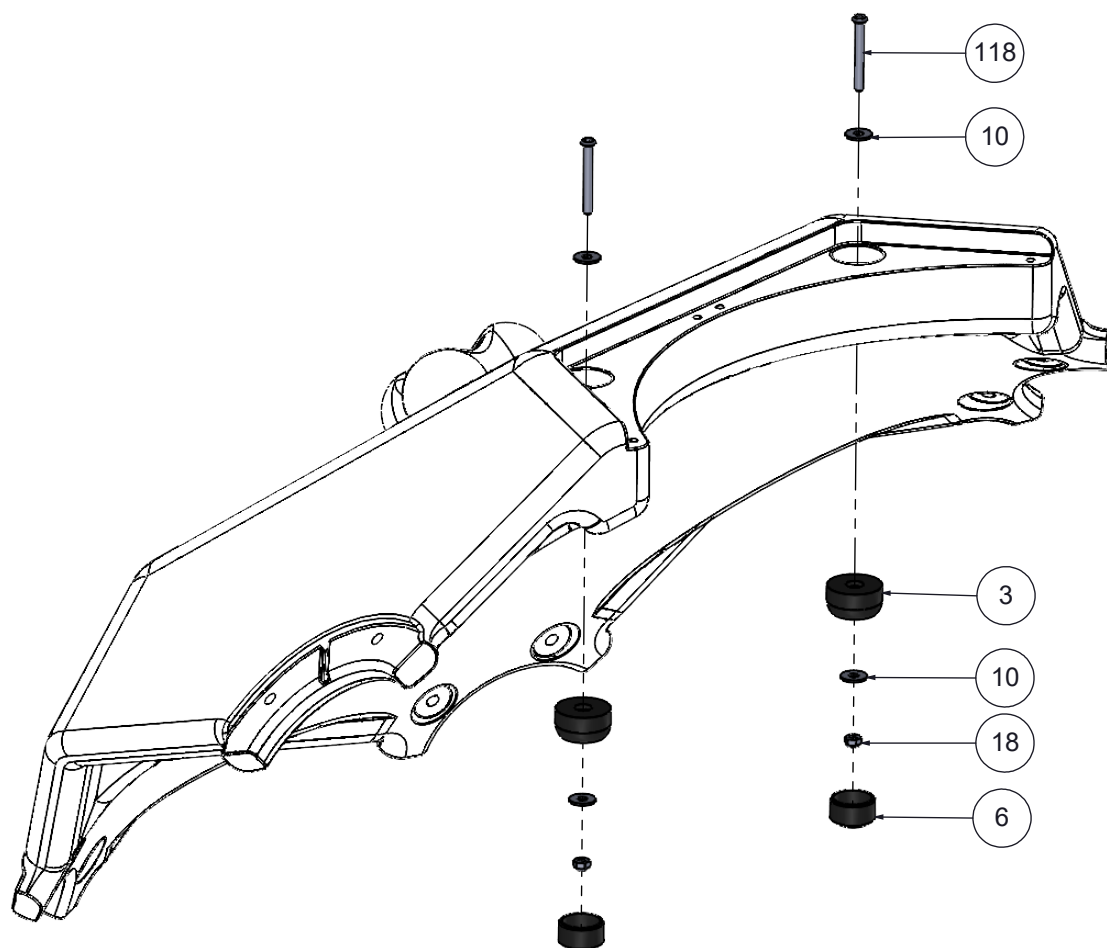

INST_95_2



Nr. 13

Nr	Σ	Element	DIN	ELEMENT
16	6		-	K1_d21_B
17	6		-	Z1_d21_B
21	6		DIN 125	8x16
31	6		DIN 985	M8 (OC)
200	6		DIN 603	M8x35

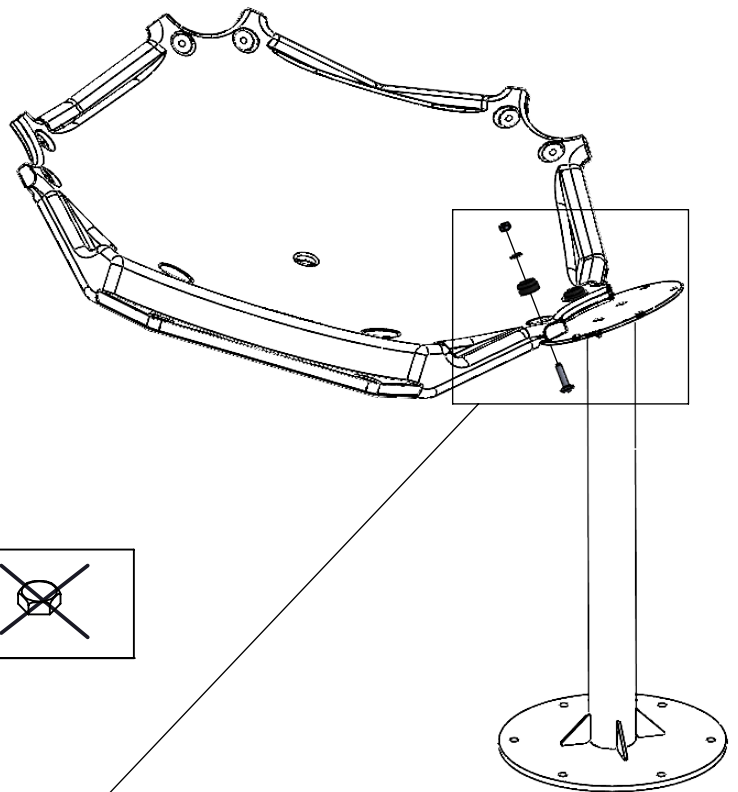

1

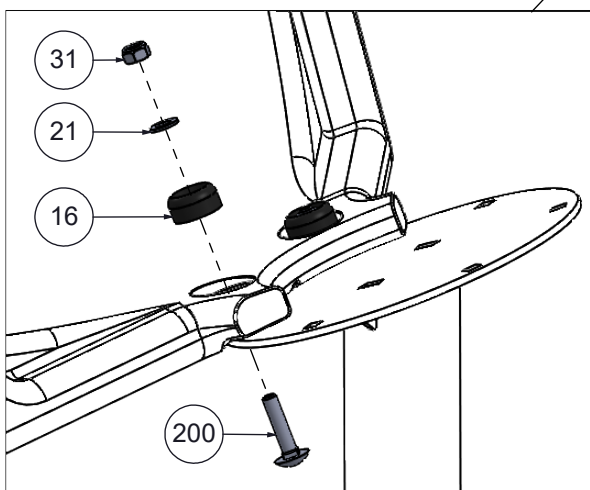
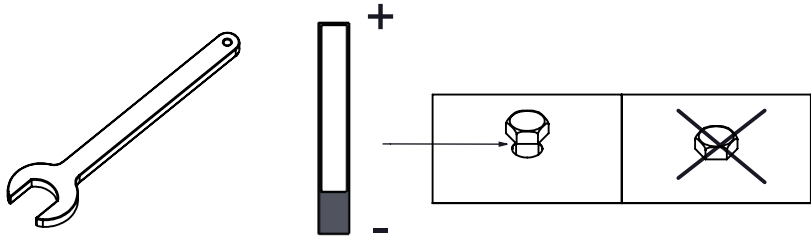

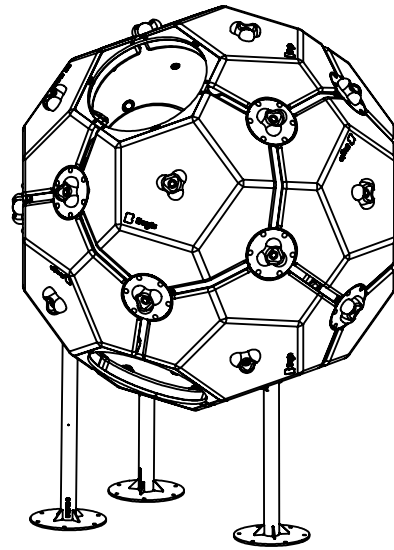
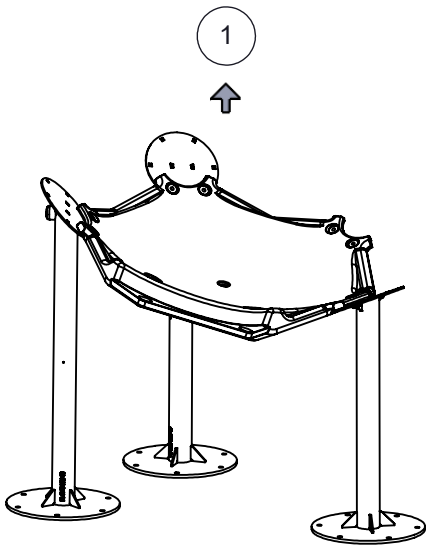

2

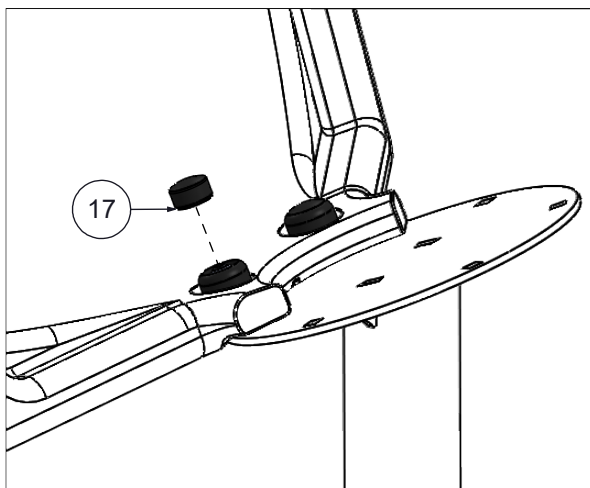
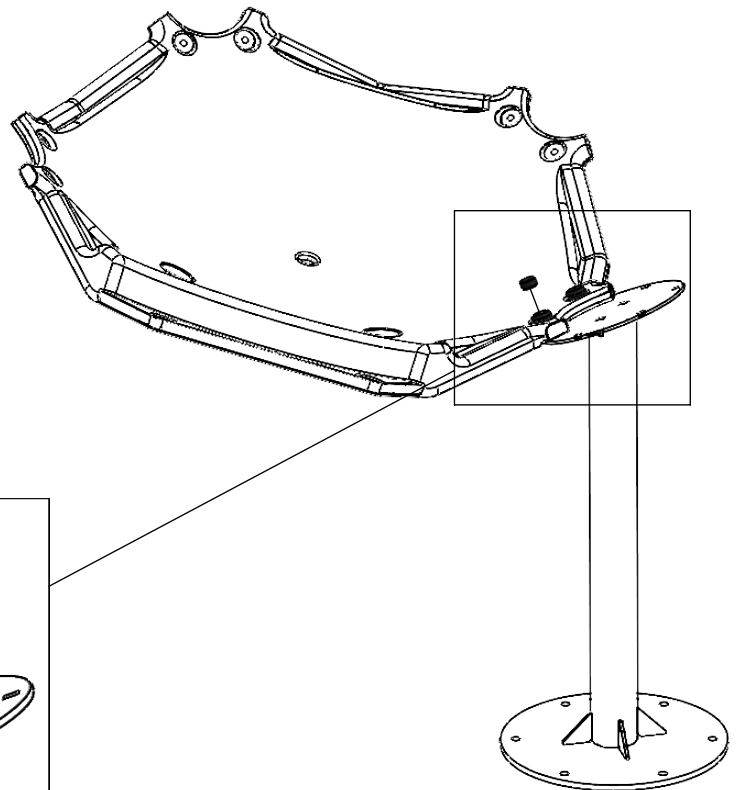
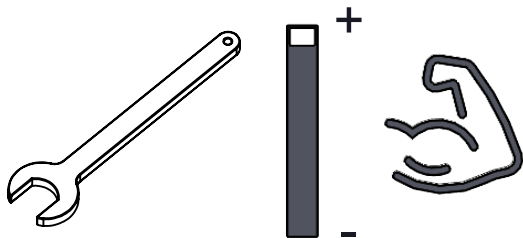

INST_95_4A_1



Nr	Σ	Element	DIN	ELEMENT
126	4		DIN 7991	M6x30

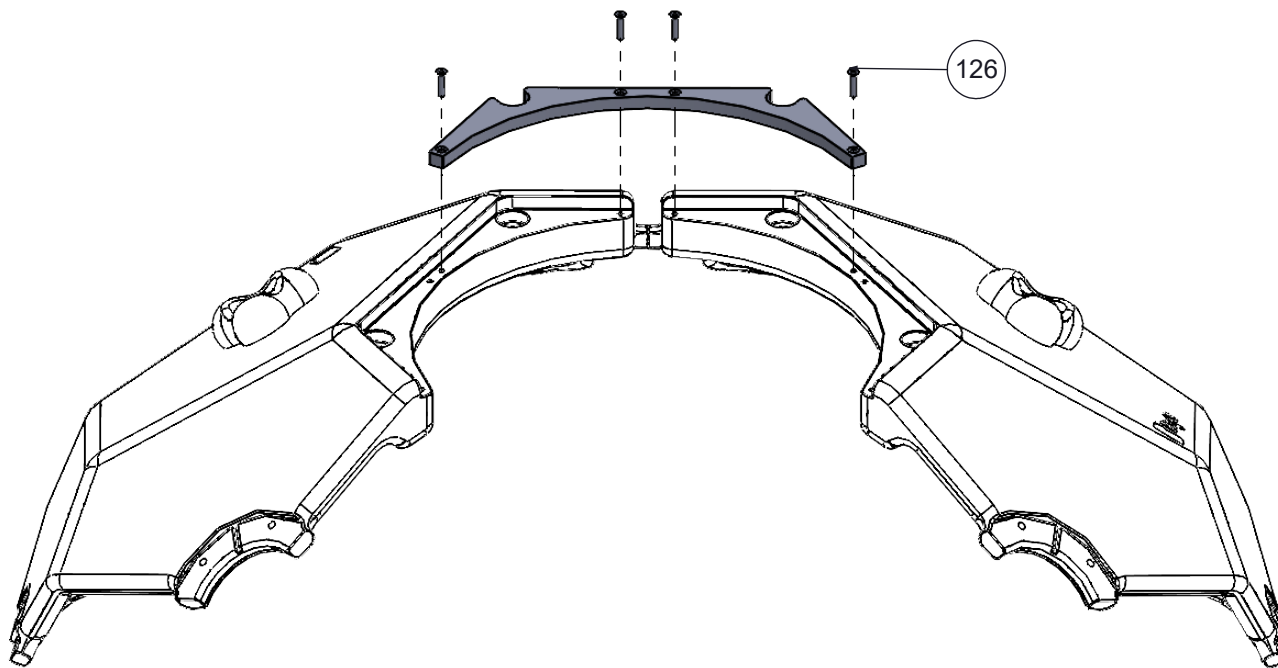

INST_95_4A_2

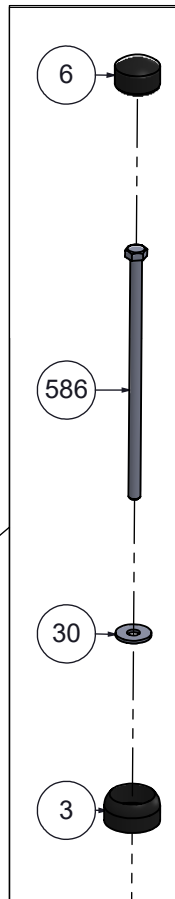
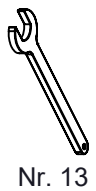

Nr	Σ	Element	DIN	ELEMENT
3	12		-	K2_d30_B
6	12		-	Z2_d30_B
30	12		DIN 9021	8x24
31	6		DIN 985	M8 (OC)
586	6		DIN 931	M8x180
587	6		-	S1_9500_4

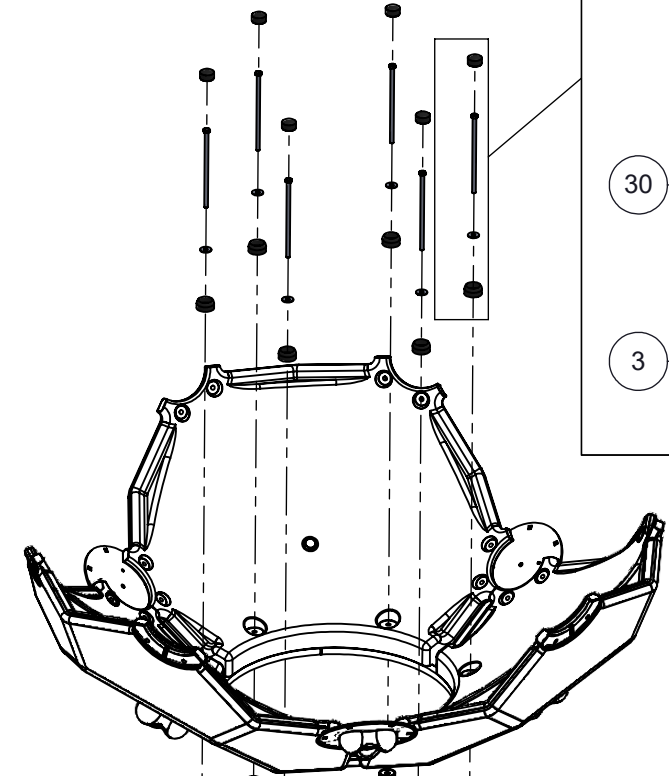

587

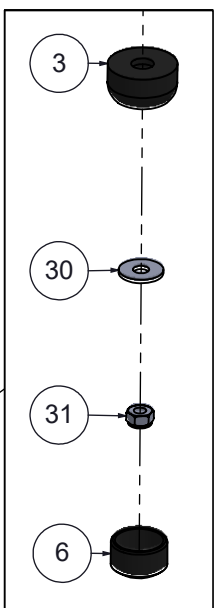
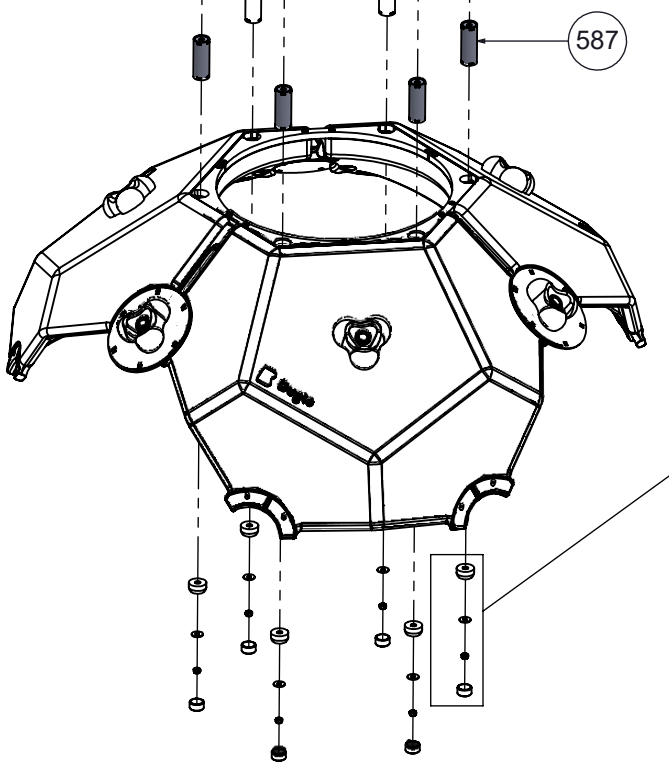

INST_95_4B

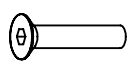

Nr	Σ	Element	DIN	ELEMENT
126	9		DIN 7991	M6x30

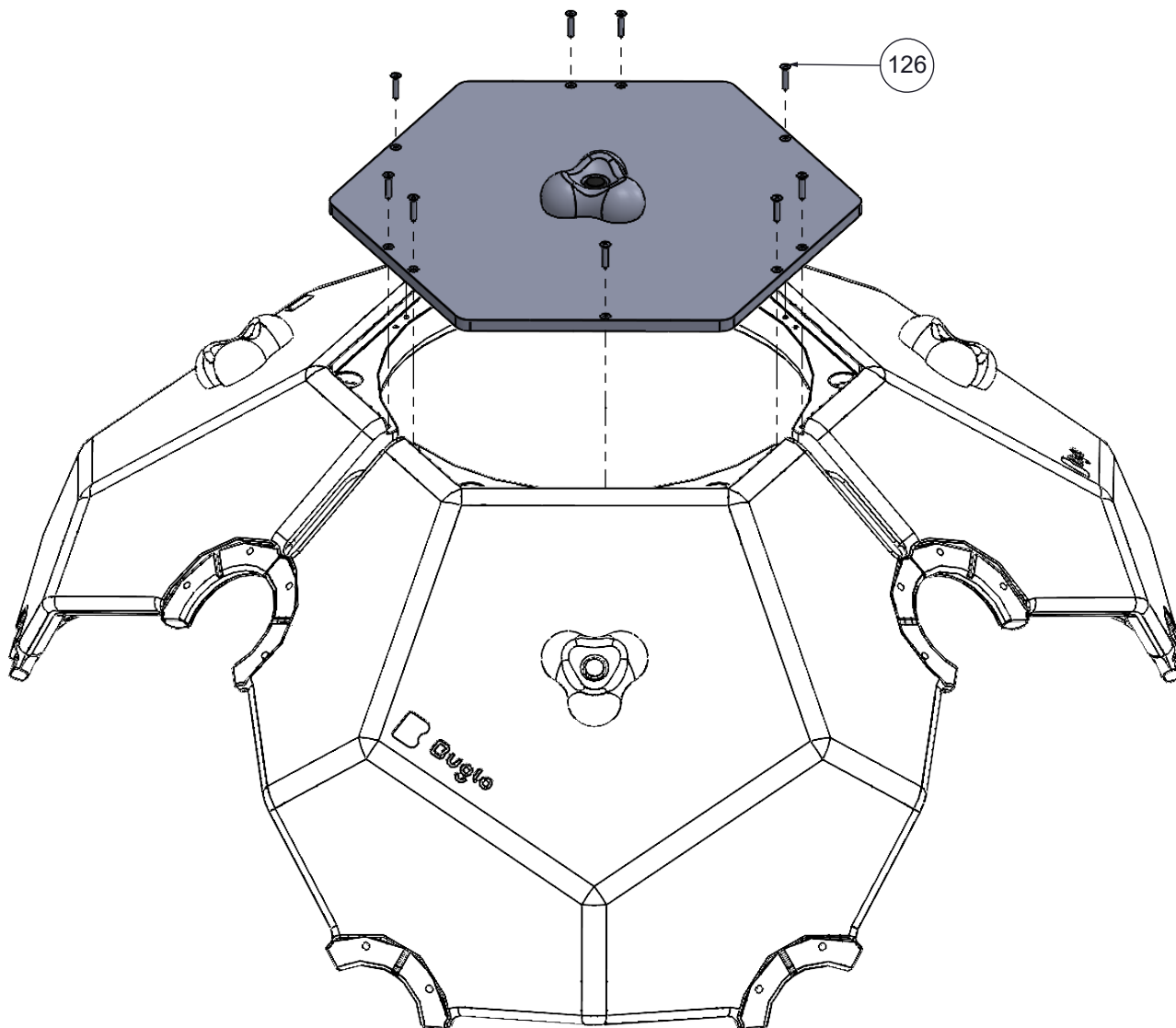

INST_95_6



Nr. 13

Nr	Σ	Element	DIN	ELEMENT
16	6		-	K1_d21_B
17	6		-	Z1_d21_B
21	6		DIN 125	8x16
31	6		DIN 985	M8 (OC)
200	6		DIN 603	M8x35

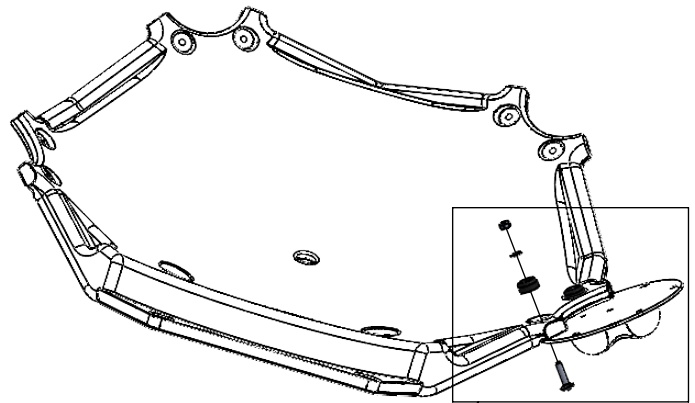

1

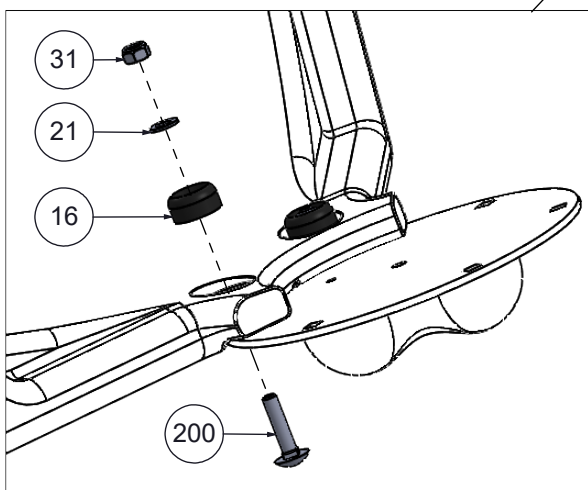
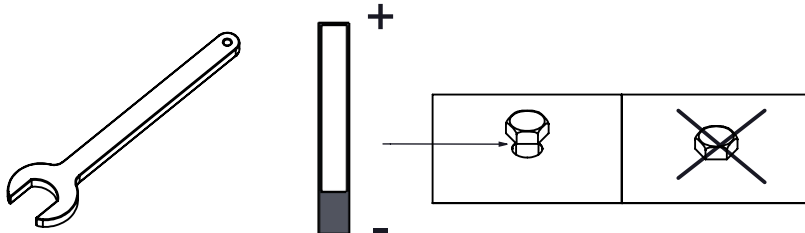

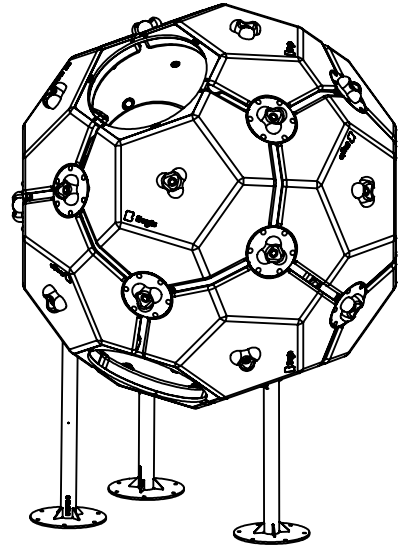
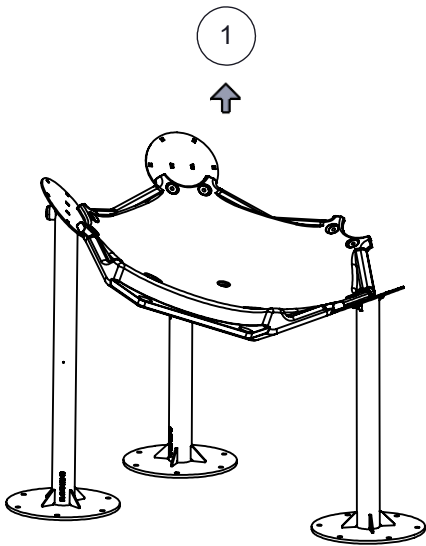

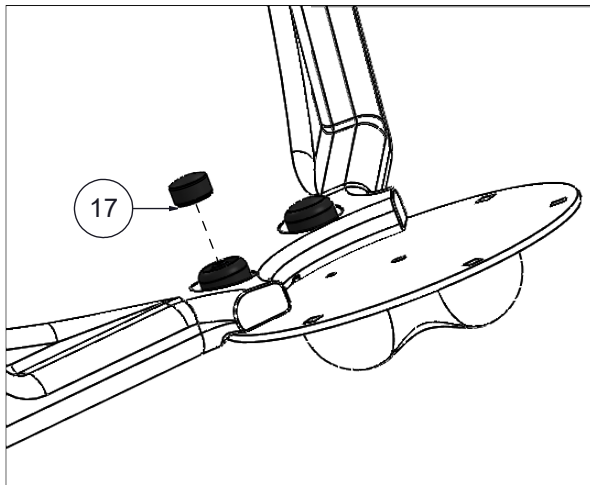
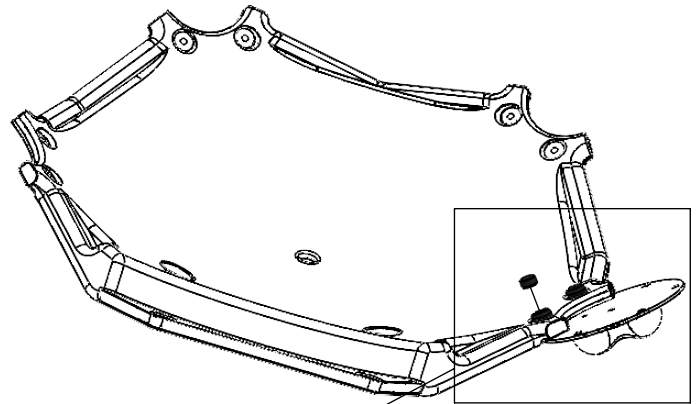
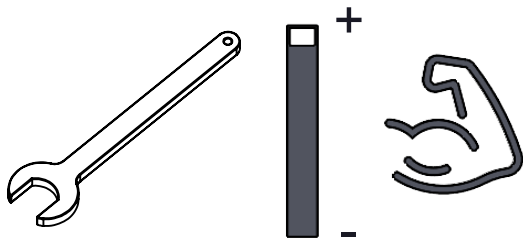

2



INST_Z_1

Nr	Σ	Element		
213	1		-	Z_NA_1
214	1		-	Z_NA_2

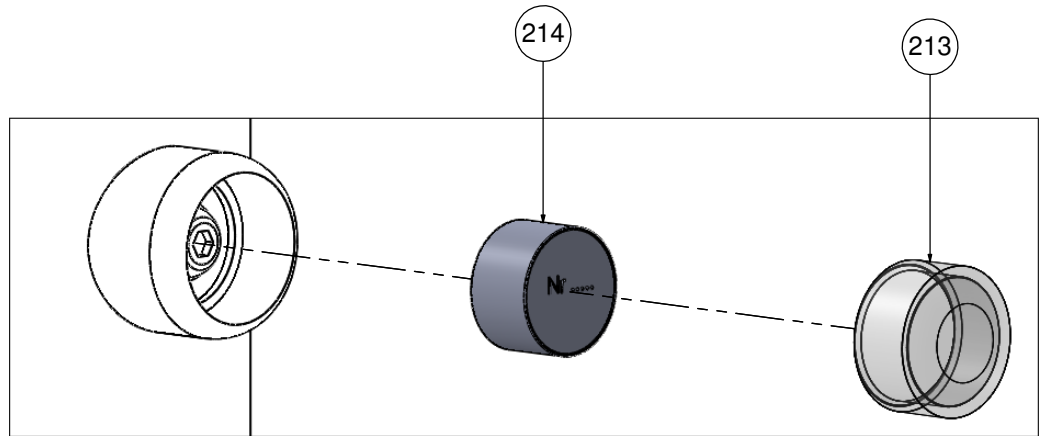
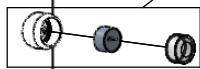

Conservation and control of the Product

According to the PN EN 1176-1 : 2017-12-Norm

The conservation and exploitation:

It is required to consult with the Manufacturer about all maintaining works of the Products' parts which are under guarantee.

The anticorrosive surface:

Damaged paint coat should be first cleaned out of dust, fat and corrosion centres. After that, the cleaned surface should be covered with an anticorrosive primer for steel surfaces. When the layer is dry, paint twice with spray paint.

The colour combination used by BUGLO according to the RAL palette:

Grey – RAL 7035, Yellow – RAL 1003, Blue – RAL 5015, Red – RAL 3000, Green – RAL 6018, Black – RAL 9005, Purple – RAL 4008, Anthracite – RAL 7016, Silver – RAL 9006, Beige – RAL 1019, Orange – RAL 2009, Brown - RAL 8017

Wood:

Elements made of glued laminated timber require a regular renovation. Depending on climate conditions, level of exploitation and mechanical damages, it is advised to renew the impregnation layer after a period of 2 – 5 years. Before finishing, timber elements need to be mattified, then following products need to be applied:

- 1) Impregnating Foundation – GORI 356
- 2) Surface paint – NORDICA EKO 3330 – 12TM1806

Products are available via distribution network of Teknos Company (www.teknos.com). Usage according to the producer's instructions.

IROKO wood: preserve with Owatrol D1.

Stainless steel:

It is recommended to clean stainless steel elements once a year, to remove sediments and contaminants, which accumulation can cause steel discolouring. Wash with cotton cloths and gentle detergent dissolved in water, eg. dishwashing liquid. After cleaning rinse with water and wipe dry.

Caution!

Cleaners used to clean stainless steel **must not** contain: chlorine, salt, acids or bleaches. Even small amount of these substances can cause permanent damage of chromium oxide surface.

Recommendations for the product control according to the EN 1176-7: 2020-Norm Playground equipment and the surfaces part 7: Guidelines for the assembly, control, conservation and exploitation/running.

- 1) Post-installation inspection – recommended before the playground opens for public use to assess the access to the product and its surroundings taking into consideration overall security level.
- 2) The periodic control – if the product is used very intensively or is exposed to vandalism, the control should be carried out once a week or more frequently.

The periodic control includes:

- potential damage of any elements,
- tightening of the connectors,
- outer coat of the set,
- condition of the shock-absorbing surface,
- bearing lubrication,
- completeness of the products,
- checking if there are no cracks, sharp edges or other damages,
- the cleanness around the Product (broken glass determines a big danger) and smoothing the safety surface,
- the presence of obstacles in the safe space or fall space and their removal if present,
- general safety status of the playground.

- 3) The functional control – should be carried out once every three months.

It includes the range of the periodic inspection enlarged by examining the product's functions.

- during the functional control the fixed elements of the product should be checked (completeness of caps and masking elements),
- checking the stability of the posts,
- checking the loose-fill safety surface (eg. sand, gravel, bark, woodchips) and evening it out. If the level is under 10cm below the marked surface level, it must be filled in,
- tighten all screws,
- checking the tensions of the zip line rope, nets and rope pyramids,
- checking of the condition of welds,
- replacing of worn or damaged elements.

4) The functional control and the main control – mandatory once a year.

The main control covers:

- checking the construction's stability,
- checking and reconstructing the anti-corrosion coating that was damaged,
- checking the foundation's condition,
- checking the loose-fill safety surface (eg. sand, gravel, bark, woodchips) and evening it out. If the level is under 10cm below the marked surface level, it must be filled in,
- checking the condition of wooden elements, if included.

The equipment should have a regular check-up control by competent people (with certified level of competence). Every time the check-up control takes place, the playground administrator should record it on inspection sheets. Any modifications of the equipment or design that may affect the basic safety of the equipment should be carried out after consultation with the manufacturer or a competent person.

All personnel involved in playground safety management must be competent.

Full range of requirements according to EN 1176-7:2020.

A sample of playground inspection sheet is included in attachment A1.

Control sheet of the playground

Administrator of the playground

Controlled equipment (product number, manufacturer number)

Check-up plan

Check-up run once a week or more often, depends on how intensively the product is used (periodically)		YES	NO
1	General condition of the safety on the playground.		
2	Tightening of the connectors, bearings lubrication, checking of the shock-absorbing surface.		
3	Is the set complete?		
4	Are there any cracks, sharp edges or other damages in the device?		
5	Is the area surrounding the device clean (no glass, safe surface horizontal/even)?		
6	Are there any obstacles in the clear space or fall space?		

Check-up run once in a three months (functional)		YES	NO
1	Are the non-separable elements complete (covers and masking elements are complete)?		
2	Are the posts stable?		
3	Is the loose safe surface horizontal/even?		
4	Is the level of the safety surface up to the marked level or is max. 10cm below this level?		
5	Is the condition of the connectors adequate?		
6	Is the condition of the welds adequate?		
7	Are the ropes and nets tensioned correctly?		
8	Replacing of worn or damaged elements.		

Check-up run once a year (functional an main)		YES	NO
1	Is the construction stable?		
2	Are there any damages to the anticorrosional coat?		
3	Is the powdery safe surface horizontal/even?		
4	Is the condition of the foundation adequate?		
5	Is the condition of wooden elements adequate?		
6	Is the level of the safety surface up to the marked level or is max. 10cm below this level?		

Fault/Repair

1	
2	
3	
4	
5	

Parts exchange

	Name of the part	Qty	Reason
1			
2			
3			

	Date	Inspector's name
1		
2		
3		
4		